

F. C. WEIR.
CAR-COUPLING.

No. 183,994.

Patented Oct. 31, 1876.

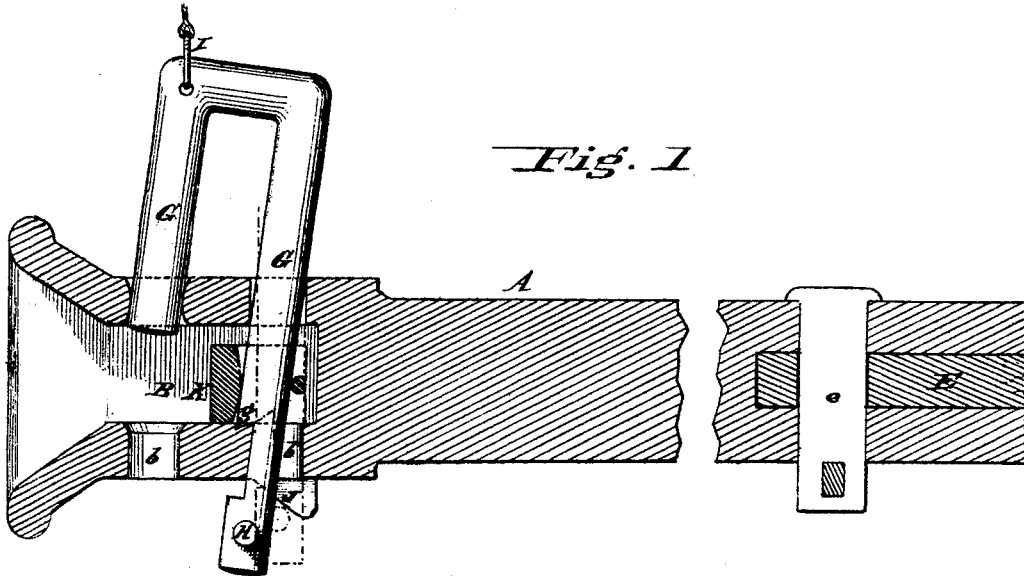

Fig. 1

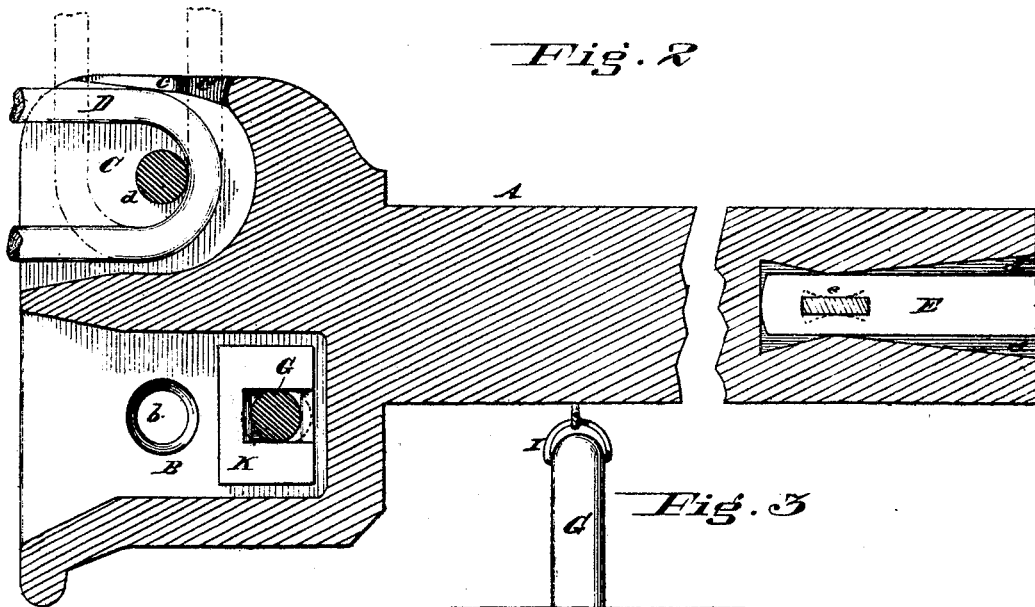

Fig. 2

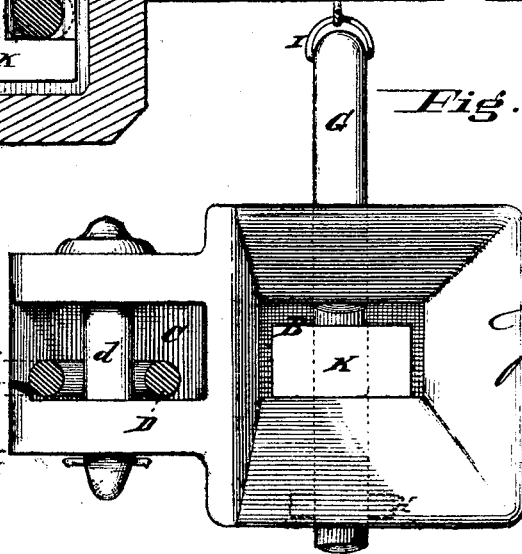

Fig. 3

Attest
Edgar Cross

Inventor
F. C. Weir
By F. Millward
Attorney

UNITED STATES PATENT OFFICE.

FREDERIC C. WEIR, OF CINCINNATI, OHIO.

IMPROVEMENT IN CAR-COUPLINGS.

Specification forming part of Letters Patent No. **183,994**, dated October 31, 1876; application filed October 19, 1874.

To all whom it may concern:

Be it known that I, FREDERIC C. WEIR, of Cincinnati, Hamilton county, State of Ohio, have invented certain new and useful Improvements in Railroad-Car Draw-Heads, of which the following is a specification:

My invention relates to a class of draw-heads for rail-cars in which the links and coupling-pins are secured permanently to the head; and consists, first, of a double pin, so hung to a lifting device that, in rising to the required height, its longest limb will gravitate to a seat and cause it to remain in an elevated position until dislodged in the act of coupling, the coupling-pin being provided with a shoulder and a pin or projection, all acting in connection with an inclined plane to move said pin forward to its seat, and render it positive in action; second, in the combination of an open coupling-box, having the above-described permanent coupling-pin, with a permanent link on the side of the box for the purpose of forming a double automatic connection between the cars; third, in forming the link-socket with a small ridge at the side, having a notch therein, into which the link can rest fixedly out of the way when not in use; fourth, in connection with a common draw-bar, the swiveling draw-head, for the purpose of centralizing the strain.

Figure 1 is a sectional elevation of my improved automatic coupler. Fig. 2 is a sectional plan of same. Fig. 3 is a front elevation of same.

A is the draw-head, having coupling-box B and link-socket C formed side by side. D is the link, secured permanently to the socket C by pin *d*. The draw-head is formed at its other end with a flaring opening, *a*, which converges to point where the key *e* of the draw-bar E is secured, where it flares away again to allow that portion of the bar E beyond pin *e* to oscillate, the longer flare doing the same office for the longer portion of bar E. The key *e* is rectangular in section, and is secured in a correspondingly-shaped hole in the bar E, and oscillates with it. The hole in the draw-head must be formed to allow this play, as shown by dotted lines, Fig. 2. The link-socket C is formed on its outer or open side with a small ridge, *c*, at the back end of which

is formed a notch, *c'*, into which one of the arms of the link can be dropped, and the link thereby held in a position (shown by dotted lines, Fig. 2) at right angles to the line of draft when not in use. The coupling-box B is formed with a flaring mouth, and has the customary draw-pin hole *b*. In this hole rests one limb of a U-shaped pin, G, whose other or longest limb rests in a second hole, *b'*, somewhat larger than the diameter of the pin. Both holes are, of course, through the coupling-box B. The pin G is intended to be permanent, and at the same time automatic in action; and it is secured for the first-named purpose in the hole *b'* by means of a pin or projection, H, and for the second-named purpose to a lifting device, I, at a position over or near the short limb, so that, on being lifted in an unbalanced position, it will, as soon as the shoulder *g* passes the top edge of the hole *b'*, tilt over by a gravitating force and seat itself, thereby making the box B an open box, or one in condition for automatic coupling at any moment. The pin G can, however, be made to answer above-described use, and not have the shoulder *g*, but may be cut off at this point and have a pin or projection which will act against the top of box B to retain the pin, and play through the floor of the box by means of a suitable notch cut therein, this limb being still sufficiently long to tilt over when relieved, and find a seat. It is self-evident that the pin will, by virtue of gravitation, seat itself; but I prefer, when using the notch or shoulder *g*, to provide inclines or incline J, which will, in acting upon projections H, carry the said shoulder positively to a position directly over its seat, upon which it will perforce drop, and, upon account of its forward incline and corresponding incline of shoulder *g*, retain that position against ordinary jars and knocks. To prevent the long leg of the pin G from being jammed and injured, I encircle it with a tripping-block, K, of such dimensions that immediately it trips the pin from its seat it will shoulder against the back of the box B, leaving the pin free to drop its short limb through the advancing link. This block can be dispensed with and not materially impair the action of coupling.

I claim—

1. In combination with pin G *g* and projection H, the incline J, operating substantially in the manner and for the purpose specified.

2. In combination with the open automatic coupling-box B and pin G, the permanent link D, adapted for self-coupling, being supported in socket C, having a back-support and a retaining side ridge, *c*, all substantially as and for the purpose specified.

3. In combination with permanent link D and its socket C, the retaining-notch *c'*, substantially as and for the purpose specified.

4. In combination with draw-bar E, the swiveling draw-head A, having flaring socket *a*, and being connected to the draw-bar by pin *e*, all substantially as described and shown, for centralizing the strain, substantially as specified.

In testimony of which invention I hereunto set my hand.

FREDERIC C. WEIR.

Witnesses:

EDGAR J. GROSS,
R. M. HUNTER.