

C. B. POST.
WIND-MILL.

No. 184,107.

Patented Nov. 7, 1876.

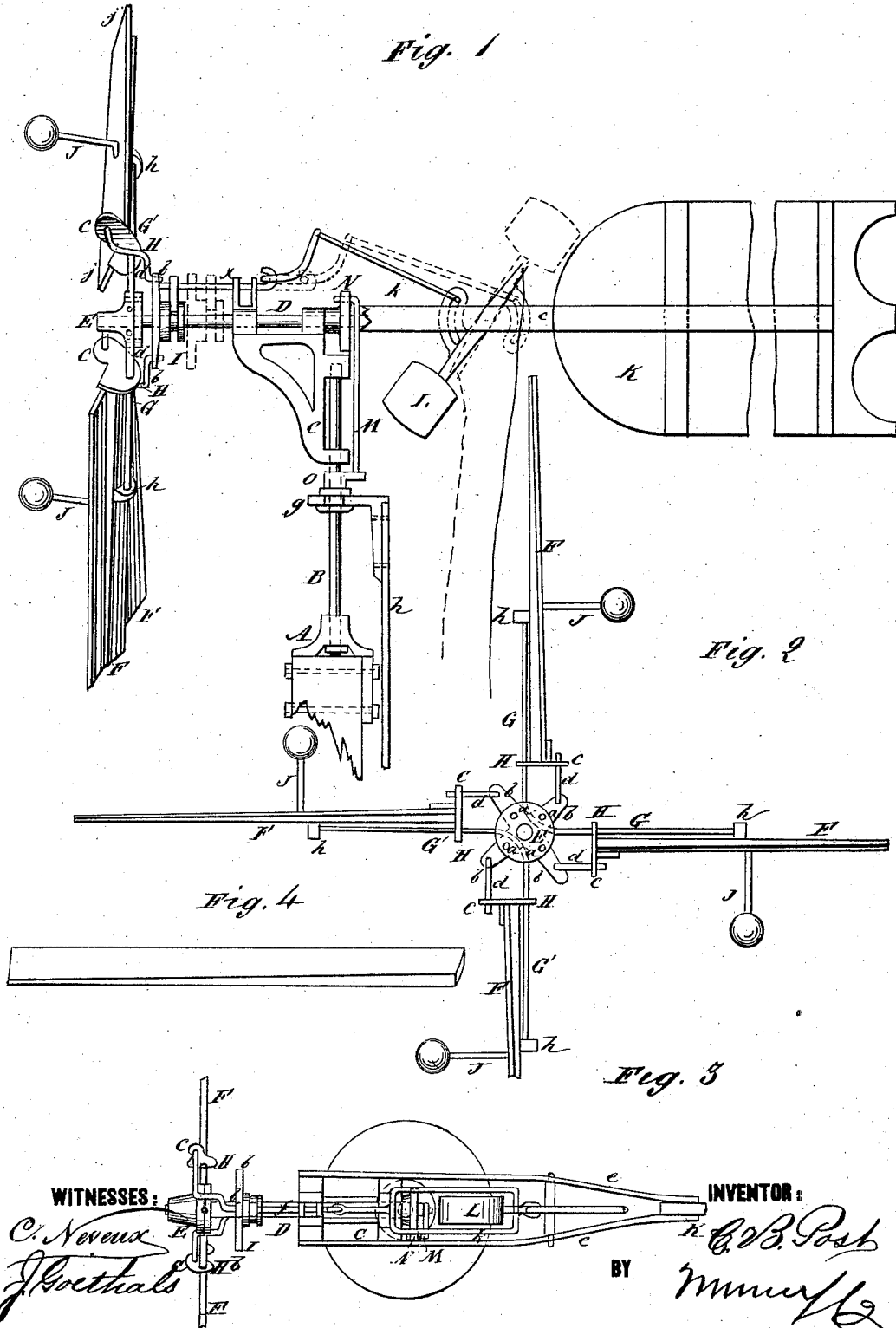

WITNESSES:

C. Neveu
J. Goethals

INVENTOR:

C. B. Post
BY *Wm. H. ...*

ATTORNEYS.

UNITED STATES PATENT OFFICE.

CHARLES B. POST, OF NEW LONDON, OHIO.

IMPROVEMENT IN WINDMILLS.

Specification forming part of Letters Patent No. **184,107**, dated November 7, 1876; application filed July 22, 1876.

To all whom it may concern:

Be it known that I, CHARLES B. POST, of New London, in the county of Huron and State of Ohio, have invented a new and useful Improvement in Windmills, of which the following is a specification:

Figure 1 is a side elevation. Fig. 2 is a front view of the wheel, showing the vanes as out of the wind. Fig. 3 is a plan. Fig. 4 is a detail view of one of the arms that support the vanes.

Similar letters of reference indicate corresponding parts.

My invention relates to an improved windmill; and it consists in the arrangement of the supporting and governing parts, which make it simple in construction, powerful in action, and self-regulating under a varying pressure of wind.

In the drawing, A is a base-piece, that supports the rod or standard B, upon which revolves the bracket or turn-table C, which supports the working parts of the mill. D is the main shaft, and E is the hub, of the wind-wheel. The sails or vanes F are pivoted on the rods G G' at H *h*. The rods G G' are curved, and secured between the parts forming the hub E, as shown by the dotted lines in Fig. 2, and are held in position by bolts *d*, that pass through the parts of the hub.

I is a sliding sleeve, carrying the arms *b*, and working on the main shaft D. The arms *b* are connected to the arms *c*, attached to the lower end of each vane F by the rods *d*, in such a way that the sliding of the sleeve I will turn the vanes F with more or less of their surfaces to the wind.

Weighted arms J project from a point near the center of each vane, at right angles, so that, as the wheel revolves, the centrifugal force of the weights tends to bring them into the line of rotation of the rods G G', turning the vanes F so as to expose less surface to the action of the wind.

The tail or guiding vane K is supported by a pair of curved strips of wood, *e*, which embrace both it and the bracket C. Between the strips *e* at the rear of the bracket C a weighted lever, L, having an arc-shaped slot, is pivoted. A forked connecting-rod, K, is

connected with the slot in the lever L, and also to a rod, *f*, that moves the sleeve I, so that when the lever L is in the position shown by the solid lines in Fig. 1 it holds the vanes to the wind; but when it is thrown over, as shown in the dotted lines, it holds the vanes in a direction parallel to the course of the wind.

M is a pitman, connected with a crank-plate, N, on the end of the main shaft D, and with a sliding sleeve, O, on the standard B. The said sleeve is grooved, and is embraced by a strap, *g*, which is attached to a rod, *h*, that transmits the power to the base of the mill.

The rib or support *i*, to which the covering of the vanes is attached, is beveled with an increasing bevel or twist throughout its entire length, giving to the vane, when made, a winding or twisted surface, as shown at *j j*.

The advantages claimed for my improved windmill are, that it is of such construction that it can be made very light, and at the same time have sufficient strength.

The governing mechanism is simple and effective, and acts in a heavy wind in such a manner as to prevent accidents to the mill.

Having thus described my invention, I claim as new and desire to secure by Letters Patent—

1. The combination of the weighted levers J, twisted vanes F, rods G G', arms *c*, connecting-rods *d*, sleeve I, and weighted lever L, substantially as shown and described.

2. The combination of the bent rods G, vanes F, and divided hub E, as shown and described.

3. The combination of the base-piece A, standard B, bracket C, shaft D, crank N, connecting-rod M, and sleeve O, as shown and described.

4. A vane for a windmill, the rib or support for which is beveled with an increasing bevel from the inner to the outer end, so that the boards which are attached to it may present a twisted or winding surface, substantially as specified.

CHARLES B. POST.

Witnesses:

STEPHEN POST,
T. M. CLOSE.