

D. AULD, Jr.

MACHINES FOR TRIMMING SLATE.

No. 184,130.

Patented Nov. 7, 1876.

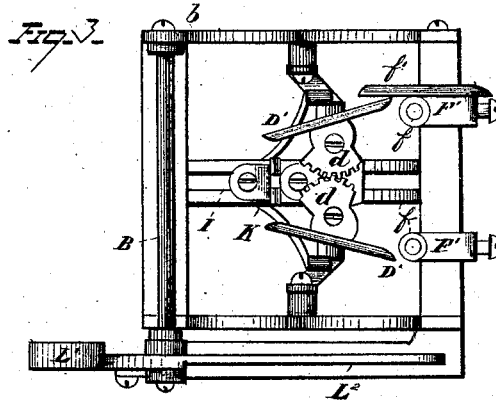
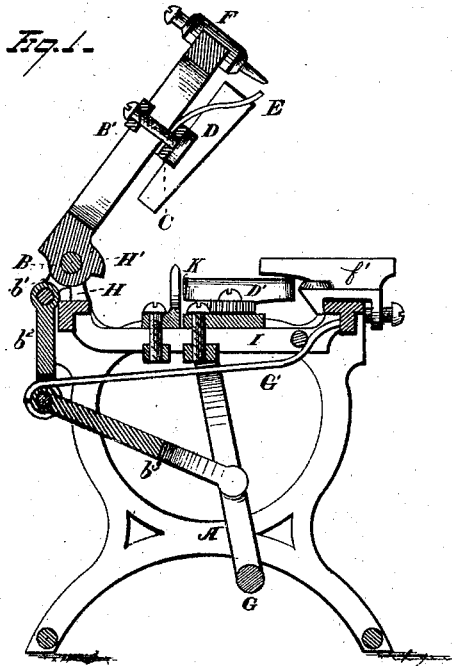
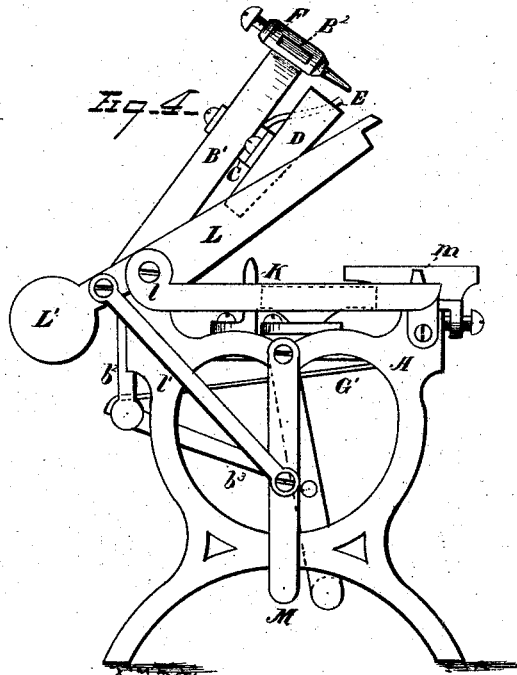
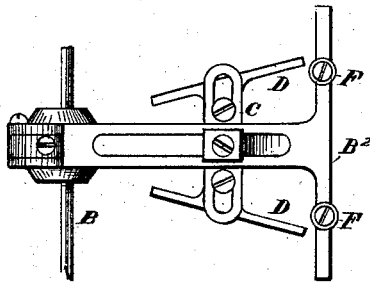

Fig. 2.



WITNESSES
C. A. Nottingham.
Albert H. Bright.

INVENTOR
David Auld Jr.
By Leggett & Leggett
Attorneys.

UNITED STATES PATENT OFFICE.

DAVID AULD, JR., OF CLEVELAND, OHIO.

IMPROVEMENT IN MACHINES FOR TRIMMING SLATES.

Specification forming part of Letters Patent No. 184,130, dated November 7, 1876; application filed March 29, 1876.

To all whom it may concern:

Be it known that I, DAVID AULD, JR., of Cleveland, in the county of Cuyahoga and State of Ohio, have invented certain new and useful Improvements in Machine for Trimming, &c., Slate; and I do hereby declare the following to be a full, clear, and exact description of the invention, such as will enable others skilled in the art to which it pertains to make and use it, reference being had to the accompanying drawings, which form part of this specification.

My invention relates to an improvement in slate trimming and cutting machinery.

In the drawings, Figure 1 represents, in central vertical section, a machine embodying my invention; Fig. 2, a plan view of the swinging frame detached from the machine. Fig. 3 represents a plan view of the table of the said machine with operating parts attached; Fig. 4, a side elevation of that part of the machine provided with the counterweighted cutter.

My invention consists of the following parts and combinations, as hereinafter set forth and claimed, wherein A is a suitable frame, so constructed as to carry and accommodate the operating portions of the device. To the frame A is hinged or journaled the frame B B¹ B², designed to carry the adjustable cutters and punches, as will hereafter more fully appear. The portion B operates as a shaft. It is suitably journaled or hinged at b to the frame A. The portion B¹ is provided with a longitudinal slot, extending along its entire length. In this slot is carried the cross-piece C, which may be adjusted and set at any point along the length of said slot. The cross-piece C carries the adjustable cutters D and the spring E. The cutters D are made adjustable to any angle, and may be straight, angular, curved, or otherwise shaped to suit the design of the slate to be cut by them. When properly adjusted they are secured in their position by suitable set-screws or clamps. The portion B² of the frame is attached at right angles to the free extremity of the portion B¹, forming therewith a T-shaped device. Upon either arm of the portion B² are provided the adjustable punches F. These punches are constructed to be adjusted at any desired point along the arm B² of the swinging frame.

The parts above described constitute what may be termed my cutter and punch frame.

There is an arm, b¹, extending from the portion B¹ of the frame beyond the shaft B. To this arm is attached a link, b², which connects it with an arm, b³, operated by a swinging treadle, G. At the junction of the swinging arm b³ and link b² operates a spring or weight, G', which comes downward with sufficient force to retain the swinging frame B B¹ B² in its elevated position. To limit the throw of the swinging frame in either direction I provide a stop, H, upon the frame A, which, by impinging in turn against the arm b¹ and the lug H' upon the swinging frame, limits the throw of the swinging frame, as above mentioned. Beneath the swinging arm B¹ of the swinging frame is provided a slot, I, in the stationary frame A, extending the entire length of the machine, and parallel to the slot in the arm B¹ above it. This slot I is designed for the accommodation of the lower adjustable cutters D'. These cutters are fashioned similarly to their companions D, and are fixed upon a frame, which may be set at any desired point along the slot I. In order to facilitate their adjustment at a proper angle to each other, the cutters D' are provided with shanks d', terminating in circular geared faces, which mesh together substantially as shown in the drawings. When the cutters D' are fixed at the desired angles, they may be secured by suitable clamps or set-screws. K is an adjustable gage or stop-piece, which may be set at any desired point along the length of the slot I. The gage K is designed to limit the feed of the slate to be cut, and is provided with a notch or slot, for accommodating the ends of the cutters D' when it is desired to bring said ends actually together in cutting diamond-shaped slate. F' are adjustable pieces, provided with openings f. These are fixed in such position that the punches F shall enter the openings f. Upon one of the pieces F' is provided the gage or stop f', which operates, in conjunction with the gage K, to secure the slate in the proper position to be cut.

The operation of the parts above described is as follows: The cutters D D' are adjusted to cut the desired pattern. The slate to be

cut is placed over the cutters D', the gages K and *f*' serving to raise it in a proper position. The swinging treadle is then operated, which results in bringing down the swinging frame B B¹ B² with its attached parts, whereby the slate is first impinged upon by the spring E, and is thereby held firmly against any movement, immediately after the cutters D D' operate to trim the slate, and the punches F and dies F' *f*' pierce the slate with holes suitable for nailing. Upon releasing the treadle G the spring or weight G' operates to lift the swinging frame and its attached parts, and permits the withdrawal of the trimmed and punched slate.

When it is desired to trim but a single edge of a slate, or to cut a slate in two, that portion of the device represented in Fig. 4 of the drawings is put in operation. This device consists of a swinging blade, L, provided with a counter-weight, L¹, which serves to keep the blade L in an elevated position when not in use. A spring may be substituted for the counter-weight L¹, if desired. The blade L is pivoted at *l* to the frame A. Back of this pivot is connected a link, *l*', which connects the blade with the foot-lever M, by operating which the counter-weight L¹ is lifted and the blade L forced down into the slot L². A suitable stop, *m*, limits the downward throw of the blade L.

It is understood that the frame upon which the slate rests may be simply two cross-pieces which leave a space between them for the descent of the blade L; or the same purpose may be accomplished by making the frame with a slot, L², formed therein, into which the blade L descends. In either case a firm support is given to the slate on both sides of the knife while the knife is severing the slate. In this way there is no danger of splitting and shattering the slate on either side of the knife L, as would be the case if there were not, as above, a firm support immediately adjacent to the knife L on both sides of it, thus giving a shearing cut on both sides of the said blade. So it is apparent that the blade L need not be hinged on one side. It is sufficient if it is made to descend into the slot at an inclination therewith, so as to give a shearing cut; and it is, therefore, apparent that the knife may descend bodily into the slot without being hinged, as above described. And it is understood that my invention contemplates, broadly, the slotted frame or support, or its equivalent, for supporting the slate, and, in connection therewith, a knife so adjusted that it will, in passing into the slot, enter it at an inclination to the plane of the slate, so as to give a shearing cut thereto.

What I claim is—

1. The combination of the slotted arm B¹, cross-piece C, and adjustable cutters D, substantially as and for the purpose shown.
2. The combination, with the swinging frame of a slate-dressing machine, of the arm b¹, link b², arm b³, spring G', and swinging

treadle G, substantially as and for the purpose shown.

3. In a slate-dresser, cutters D or D', geared together in such a manner as that the adjustment of one blade shall operate to properly adjust its companion, substantially as and for the purpose shown.

4. The swinging blade L, in combination with the slot L², substantially as and for the purpose shown.

5. The combination of the blade L and stop *m*, substantially as and for the purpose shown.

6. In a machine for punching and cutting roofing-slates, the combination of the adjustable cutters and punches secured to a single hinged frame.

7. In a machine for cutting and punching roofing-slate, the combination of punches with the free end of a hinged frame carrying adjustable cutters, whereby the slate is securely held between the cutters as the slate is punctured by the punches, substantially as and for the purpose set forth.

8. In a machine for cutting and punching roofing-slate, the combination, with a longitudinally-slotted swinging frame, of cutters and suitable fastening devices, whereby the cutters may be adjusted in the swinging frame, substantially as and for the purpose set forth.

9. In a machine for cutting and punching roofing-slate, the combination, with a cross-arm of the swinging frame, of adjustable punches, substantially as and for the purpose set forth.

10. In a machine for cutting and punching roofing-slate, the combination, with the cutters D D' and punching device F F' *f*, of the side gage *f*', substantially as and for the purpose set forth.

11. In a machine for cutting and punching roofing-slate, the combination, with adjustable stationary cutters, of adjustable cutters secured to a single swinging frame, substantially as and for the purpose set forth.

12. The combination, in a slate cutting and punching machine, of a frame or bed supporting adjustable bearers, guides, and dies, a movable frame, bearing adjustable cutters and punches, and a spring for holding the slate snugly upon the frame, substantially as and for the purposes described.

13. The combination, in a slate-machine, of stationary curved bearers and movable curved cutters, substantially as and for the purposes described.

14. The combination, in a slate-machine, of adjustable curved bearers, supported on the frame or bed, and adjustable cutters, supported on a movable frame, substantially as and for the purposes set forth.

In testimony whereof I have signed my name to this specification in the presence of two subscribing witnesses.

DAVID AULD, JR.

Witnesses:

LEVERETT L. LEGGETT,
FRANCIS TOUMEX.