

J. R. BLAKESLEE & E. E. PIERCE.

COUPLING-PIN, BOLT AND RIVET MACHINE.

No. 184,135.

Patented Nov. 7, 1876.

Fig. 1,

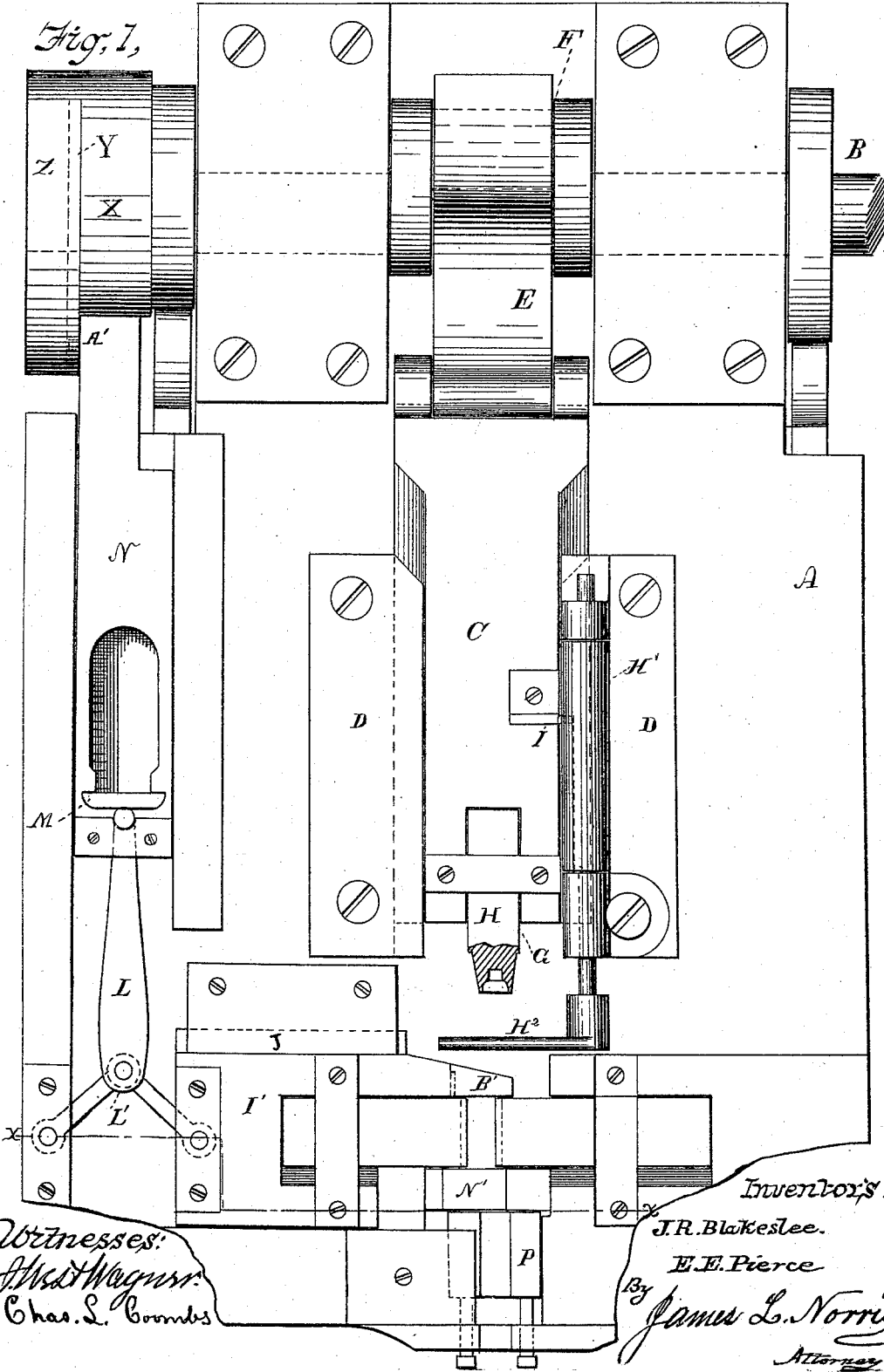

Witnesses:
Wm. Wagner
Chas. L. Combs

Inventors:
J.R. Blakeslee.
E.E. Pierce
By James L. Norris.
Attorney

J. R. BLAKESLEE & E. E. PIERCE.

COUPLING-PIN, BOLT AND RIVET MACHINE.

No. 184,135.

Patented Nov. 7, 1876.

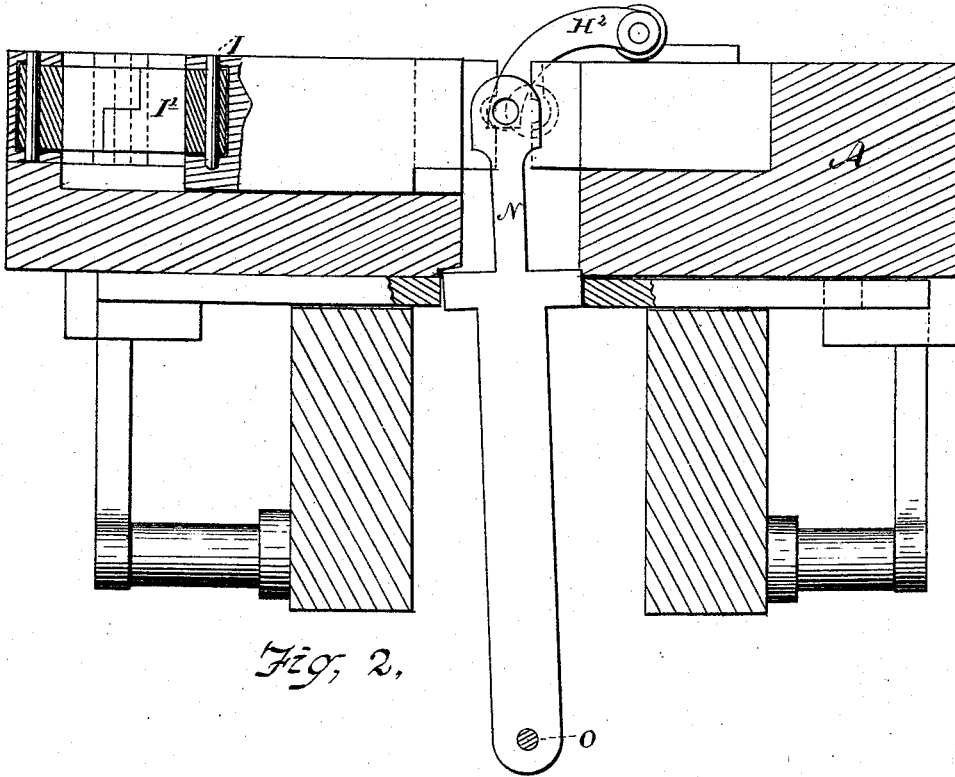

Fig. 2.

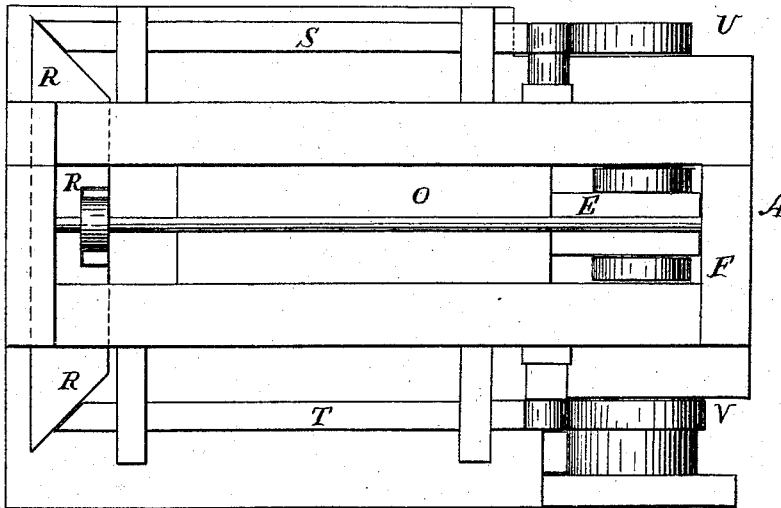

Fig. 3.

Witnesses.

Wm. Wagner.

Chas. S. Coombs.

Inventors:

J. R. Blakeslee.

E. E. Pierce.

James L. Norris

UNITED STATES PATENT OFFICE.

JOHN R. BLAKESLEE, OF CLEVELAND, AND ERASTUS E. PIERCE, OF
CUYAHOGA FALLS, OHIO.

IMPROVEMENT IN COUPLING-PIN, BOLT, AND RIVET MACHINES.

Specification forming part of Letters Patent No. **184,135**, dated November 7, 1876; application filed
September 30, 1876.

To all whom it may concern:

Be it known that we, JOHN R. BLAKESLEE, of Cleveland, in the county of Cuyahoga and State of Ohio, and ERASTUS E. PIERCE, of Cuyahoga Falls, in the county of Summit and State of Ohio, have invented certain new and useful Improvements in Coupling-Pin, Bolt, and Rivet Machines, of which the following is a specification:

This invention relates to certain improvements in machines for forming coupling-pins, rivets, bolts, and other like articles, its object being to cut the bolt from each side toward the center, so as to leave the rod with such a shaped end that when next presented to the action of the header the metal will be upset equally on all sides, and not tipped and upset to one side, as in the machines heretofore in use; also, to so construct the cutter that it may be employed with different-sized dies, and adjusted so as to form a solid backing for the same, and to so construct the parts by which the reciprocating die-box is operated, that in the event of an obstruction coming between the dies a detachable safety-stop will be fractured or broken, and allow the slide which operates the reciprocating die-box to move independently of said die-box, and thus prevent injury to the machinery; and, finally, to provide for operating the reciprocating die-box and clearer, so that said clearer will pass free of the stationary die on its backward movement, and effectually remove the bolt or rivet, and on its return will pass back of the stationary die a slight distance before the reciprocating die is given its final home motion, in order to allow the blank to be fed in without coming in contact with the clearer.

My invention consists, first, in the combination of a double-acting cutter with a reciprocating die-box, operating together in such manner as to cut the bolt, pin, or rivet from the bar from each side to the center, so as to leave the end of the bar in proper position to the header for heading the next succeeding bolt, substantially as hereinafter more fully set forth; second, in the combination, with the reciprocating die-box, of a clearer and double-acting cutter, so arranged relatively that the clearer, after freeing the finished bolt from

the dies, will pass back of the stationary die, so as to be out of the way of the blank when next fed in, as more fully hereinafter set forth; third, in the combination with the intermittent reciprocating die and its clearer, of a double-acting die adapted to cut the blank from one side at the first movement of the parts, and at the second movement from the opposite side, as hereinafter more fully set forth; fourth, in the combination, with the reciprocating and stationary dies, of an adjustable die and backing device located between the said dies and the feed-opening of the apparatus, which may be adjusted to operate with different-sized dies, and afford a solid backing to the same, as more fully hereinafter set forth; fifth, in the combination, with the reciprocating die-box, having an intermittent forward movement and a continuous backward movement, of a clearer, cutter, and header, the whole arranged to operate together so as to allow the blank to be partially cut on the first movement, then fed in and clamped, then to be headed and fully cut, and finally cleared from the dies, as more fully hereinafter set forth.

In the drawing, Figure 1 represents a top view of my apparatus; Fig. 2, a section on line *xx* of Fig. 1; and Fig. 3 a view of the under side of the apparatus.

The letter A represents the frame or bed of the machine, which supports the various working parts, and which is substantially made of iron or other suitable material, in order to bear the strain to which it will be subjected. B represents the driving-shaft, journaled near the rear end in the frame A, the ends projecting at each side, and provided with cams for operating the reciprocating die-box, header, and cutter, as hereinafter to be explained. The letter C represents a reciprocating slide, setting between and adapted to travel in the ways D D, secured to or forming part of the frame A. To the rear end of said slide is secured a connecting-rod, E, which, at its rear end, encircles a crank, F, forming part of the journal or driving shaft B. Said reciprocating slide is provided with a slot or recess, G, at its front end for the reception of the header H. On one of the ways is journaled a longitudinal shaft, H¹,

carrying at its forward end a gage, H², said shaft being operated to show the gage in and out of the way of the header, as occasion requires, by means of an arm, I, attached to the slide C, and working in a slot in the shaft H¹. The letter I' represents a reciprocating die-box, setting and adapted to travel in the ways J J in the front of the apparatus. Said reciprocating die-box receives its motion through the medium of a rod, L, connected at one end to the knuckle-joint L', and at the other end bearing against a detachable stop, M, set in the slide N, which will break at any undue strain caused by an obstruction between the dies. The letter N' represents the cutter, which consists of a metallic bar attached loosely at its lower end to a rod, O, extending longitudinally under the lower part of the machine, and secured at each end to the standards thereof. The upper part of said cutter lies between an adjustable backer, P, and the dies, and is operated by a reciprocating slide, R, having its ends beveled, as shown, against which the reciprocating rods S and T, on opposite sides of the apparatus, work, said rods being operated alternately, by the cams U and V, on the opposite ends of the driving-shaft. The slide N receives its forward motion from a cam, X, on the driving-shaft, and its backward motion from a cam-groove, Y, in the cam-plate Z, in which a pin, A', attached to the end of said slide, sets and travels. The cam X is shaped, as shown in the drawing, so as to give the reciprocating carrier an intermittent forward movement, so as to pass the clearer B' back of the stationary die on the first movement of the reciprocating die-box, in order to remove it, so that the blank can be inserted; then to allow the reciprocating die to remain stationary until the blank is fed, and finally to clamp and hold it while subjected to the action of the header, which comes against its end while clamped between the two dies.

The operation of the apparatus is as follows: In Fig. 1 the apparatus is shown with the parts in position for the blank to be fed in. The clearer attached to the reciprocating die-box in this position is shown as it lies after the first motion of the reciprocating slide, leaving the feed-opening free for the insertion of the blank. While in said position the blank is

inserted, and on the second motion of the reciprocating die the blank is forced against one side of the cutting-edge of the cutter, partially cutting and clamping said blank. The cutter then travels in the same direction that the reciprocating die has traveled on its forward movement, so as to bring the other cutting-edge of the cutter against the rod, and entirely separate the blank from said rod.

What we claim, and desire to secure by Letters Patent, is—

1. The combination of a double-acting cutter with a reciprocating die-box, substantially as described, whereby a bolt, pin, or rivet is cut from each side to the center, as set forth.

2. The combination of an intermittent die-box with a clearer and a double-acting cutter, substantially as described.

3. The combination of an intermittent reciprocating die-box and its clearer with a double-acting cutter and a suitable header, substantially as described.

4. The shear and backing, located between the dies and the feed-opening of the machine, the two being made adjustable, whereby the shear may be adapted to operate with different-sized dies, and form a solid backing for the same against the action of the header, substantially as described.

5. The reciprocating die-box, having an intermittent forward motion and a backward motion, in combination with the clearer, cutter, and header, the whole operating as described, for the purpose of feeding and partially cutting the blank on the forward motion of the reciprocating die, and clearing the work from the dies on the backward motion of the reciprocating die, the blank being finally cut and headed while the dies are clamped together between the forward and backward movements of the die, substantially as described.

In testimony that we claim the foregoing we have hereunto set our hands in the presence of the subscribing witnesses.

JOHN R. BLAKESLEE.
ERASTUS E. PIERCE.

Witnesses:

JOS. L. COOMBS,
JAMES L. NORRIS.