

J. CHAPMAN.

PLUGS FOR DRAIN-PIPES, &c.

No. 184,143.

Patented Nov. 7, 1876.

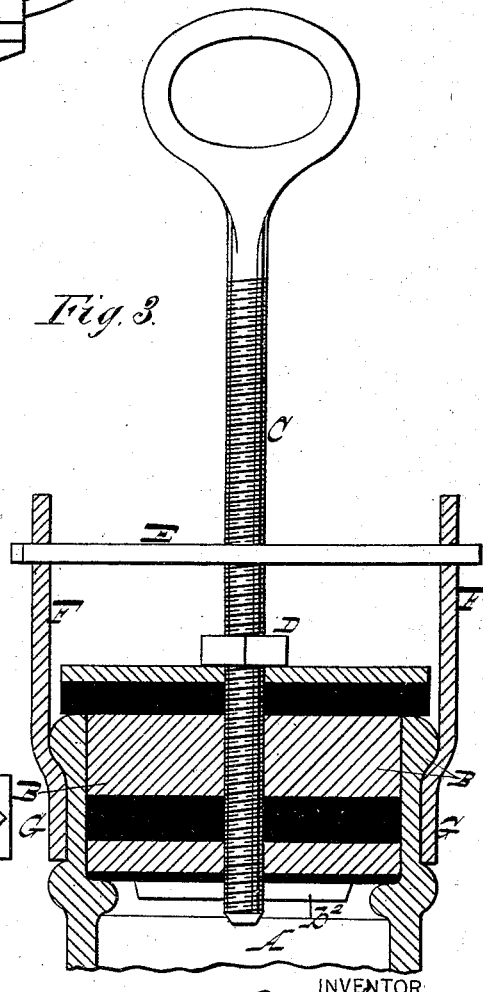
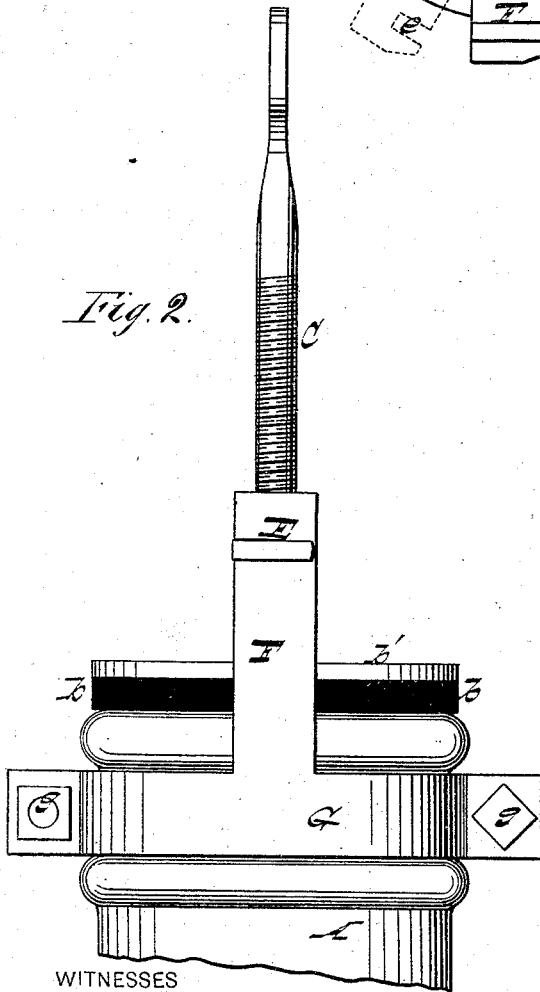
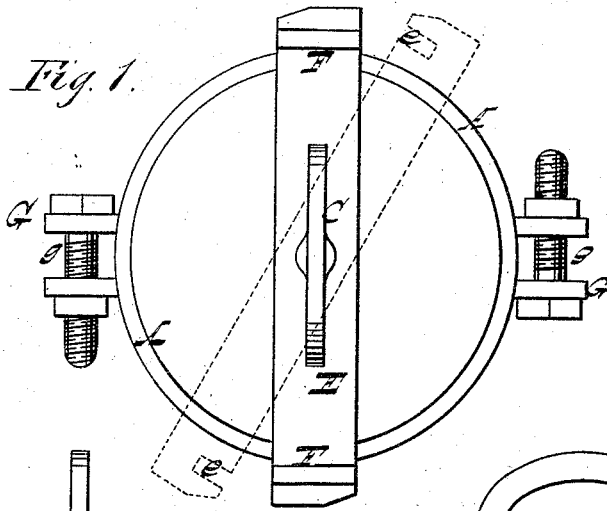

WITNESSES

W. P. Utley.
J. M. Mitchell.

INVENTOR

John Chapman
Per Edson Bird.

ATTORNEYS

UNITED STATES PATENT OFFICE.

JOHN CHAPMAN, OF WASHINGTON, DISTRICT OF COLUMBIA.

IMPROVEMENT IN PLUGS FOR DRAIN-PIPES, &c.

Specification forming part of Letters Patent No. 184,143, dated November 7, 1876; application filed October 16, 1876.

To all whom it may concern:

Be it known that I, JOHN CHAPMAN, of Washington, in the county of Washington, in the District of Columbia, have invented certain new and useful Improvements in Plugs for Drain-Pipes, &c.; and I do hereby declare that the following is a full, clear, and exact description thereof, which will enable others skilled in the art to which it appertains to make and use the same, reference being had to the accompanying drawings, and to the letters of reference marked thereon, which form a part of this specification, and in which—

Figure 1 is a plan view of my improved plug for drain-pipes, &c. Fig. 2 is a side elevation, and Fig. 3 a vertical section, of the same.

Corresponding parts in the several figures are denoted by like letters.

This invention relates to a certain improvement in plugs specially designed for insertion in drain-pipes in cellars, &c., to prevent the filling of the latter with water in the event of an overflow; and it consists of a plug, in one piece or more, and manipulated by a screw and nut, which are adjusted to the pipe by mechanism, substantially as hereinafter more fully set forth.

In the annexed drawing, A refers to a portion of a drain-pipe, such as is used in cellars, &c., and connecting with the sewer. B is a plug, in one or more pieces, and capped, preferably, by a rubber disk, *b*, covered by a metallic plate, *b*¹, to furnish a suitable bearing for the tightening-nut, hereinafter referred to more particularly. C is a screw, ringed or

otherwise adapted, at one end, for convenience in handling and passing through the plug B and its rubber disk *b* and plate *b*¹, to which it is held partly by the plate or nut *b*² upon its lower end. D is a nut upon the screw C, and resting upon the plate *b*¹, against which it bears when tightened. The screw C passes through a plate, E, slotted from opposite sides, near its outer ends, as at *e e*, which receive metallic uprights or bars F F, extending from semicircular clamps G G, encircling the pipe A, and connected together by the screw-bolts *g g*, or other suitable means. By tightening the nut D with a wrench or other suitable tool, the screw-holding plate E being locked in position upon the bars F F, the plug B will be firmly secured in the pipe. Loosen the nut D, and disengage the plate E from the bars F F of the clamps G G, when the plug B can be removed and put away for further use.

Having thus described my invention, what I claim, and desire to secure by Letters Patent, is—

The plug B, having the screw C, provided with the nut D and plate E, in combination with the clamps G G, having the arms or bars F F, substantially as and for the purpose set forth.

In testimony that I claim the foregoing as my own I hereunto affix my signature in presence of two witnesses.

JOHN CHAPMAN.

Witnesses:

J. WM. MISTER,
W. T. JOHNSON.