

J. W. CHEWNING, Jr.
HORSESHOE MACHINES.

No. 184,144.

Patented Nov. 7, 1876.

Fig. 1.

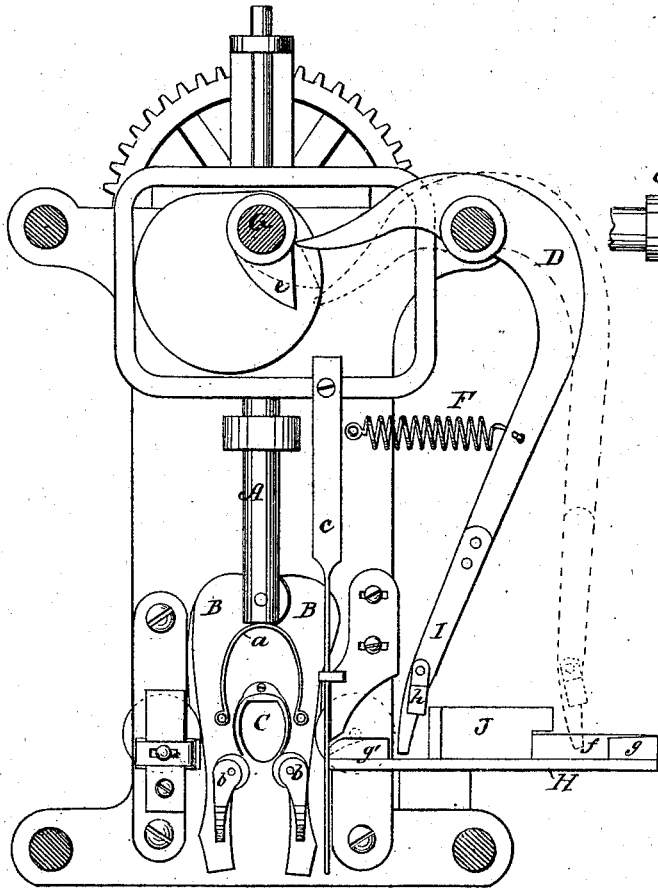

Fig. 2.

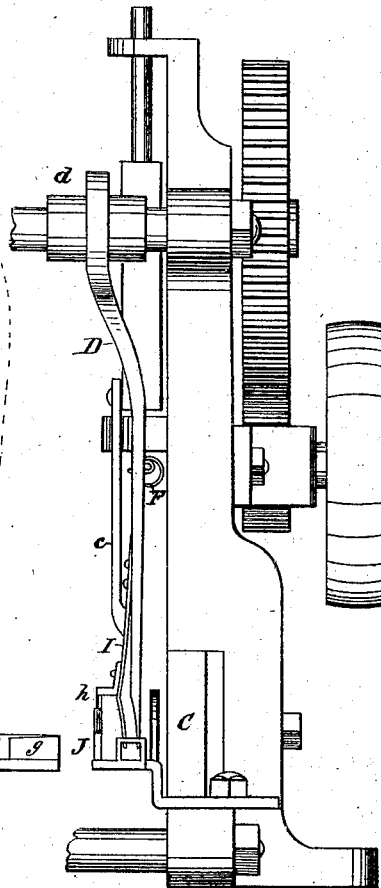
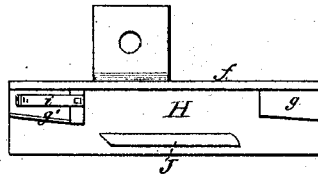

Fig. 3.



WITNESSES:

W. W. Hollingsworth
John Kemm

INVENTOR:

Jno. W. Chewning Jr.

BY

Russell & Co.

ATTORNEYS.

UNITED STATES PATENT OFFICE.

JOHN W. CHEWNING, JR., OF SHADWELL DEPOT, VA., ASSIGNOR TO HIMSELF,
THOMAS COOPER FEREBEE, OF CAMDEN COURT HOUSE, N. C., AND JULIA
MAY WALLACE, OF DEEP CREEK, VA.

IMPROVEMENT IN HORSESHOE-MACHINES.

Specification forming part of Letters Patent No. 184,144, dated November 7, 1876; application filed
September 4, 1876.

To all whom it may concern:

Be it known that I, JOHN W. CHEWNING, Jr., of Shadwell Depot, in the county of Albemarle and State of Virginia, have invented a new and Improved Feeder for Horseshoe-Machines; and I do hereby declare that the following is a full, clear, and exact description of the same, reference being had to the accompanying drawing, forming part of this specification, in which—

Figure 1 is a side view of the feeding devices applied to the machine, which is partly shown in vertical transverse section. Fig. 2 is an edge view of the same; Fig. 3, a detail plan view of the feeding-table.

My invention relates to certain improvements upon the horseshoe-machine for which Letters Patent were granted me August 29, 1876, and it consists in the construction and arrangement of a device for feeding the bar from which the shoe is made to the machine, whereby the operation of the same is rendered automatic, as hereinafter more fully described.

In the accompanying drawing the feeder is shown applied to my said patented machine, which is here only shown in part, sufficient to illustrate the operation of the same. For a complete understanding of said machine reference to the original patent will be necessary.

A represents a vertically-reciprocating bar, carrying the pivoted bending-jaws B B, which latter are pressed apart by the spring *a*, and are provided with rollers *b b*. The bar of iron is placed upon the rollers *b b*, and cut off by the knife *c* the proper length. Now, as the jaws are elevated, the rollers *b b* bend the section of the bar around the horizontal swaging-die, (not shown,) which latter advances and swages it into proper shape against the female die C.

In order to render the feeding of the bar automatic, I have constructed and combined the following devices: A bent lever, D, is pivoted upon a shaft, E, with a long bearing, *d*, and its lower arm is arranged to be drawn in-

wardly by a spring, F, while its upper arm is struck by a cam, *e*, upon a revolving shaft, G, so as to give, at the proper interval, a vibrating movement to the said lever. H is a table or plate arranged to support the horseshoe-bar, which table is maintained upon suitable supports upon a level with the upper surface of the bending-jaw rollers when the latter are in their lowest position. This table is provided upon one side with a guide-flange, *f*, which steadies the lower end of the lever and feeding-throats *g g'*, through which the bar loosely passes to the machine, and by which the bar is securely held against lateral displacement. The lower end of the lever is provided with a gripping-spring, I, provided with a hook, *h*, while the table H is furthermore provided with a deflector-plate, J, beveled at its opposite ends upon opposite sides. Now, as the lever vibrates from the combined action of the cam and spring, its lower end moves back and forth over the table, carrying the horseshoe-bar, its movement being rendered true and free from lateral variation, by reason of the long bearing of the pivot and the guide-flange of the table. As the lower end of the lever passes back, the hook *h* passes upon the outside of the deflector-plate, opening the griper formed by the spring I and the lower end of the lever. As it passes off the end of the deflector-plate the grippers close upon the bar, and, after the cam *e* passes, the spring F operates to feed the bar to the machine, the hook *h* passing upon the inside of the deflector-plate in its forward movement, and a spring, *i*, serving to prevent the accidental withdrawal of the bar on the backward movement. The operation of feeding is thus rendered automatic by the devices just described, and the feeding of the hot bars effected in a perfect and reliable manner.

Having thus described my invention, what I claim as new is—

1. The combination of the shaft G, having cam *e*, the lever D, spring F, the gripping-spring I, having hook *h*, and the table H

having deflector-plate J, substantially as and for the purpose described.

2. The vibrating lever D, carrying a gripping attachment at its lower end, provided with hook *h*, in combination with the table having deflector-plate J, throats *g g'*, and guide-flange *f*, substantially as and for the purpose described.

The above specification of my invention signed by me this 2d day of September, 1876.

JOHN W. CHEWNING, JR.

Witnesses:

EDWD. W. BYRN,
CHAS. A. PETTIT.