

W. D. JONES.
BROOM-WINDING MACHINE.

No. 184,157.

Patented Nov. 7, 1876.

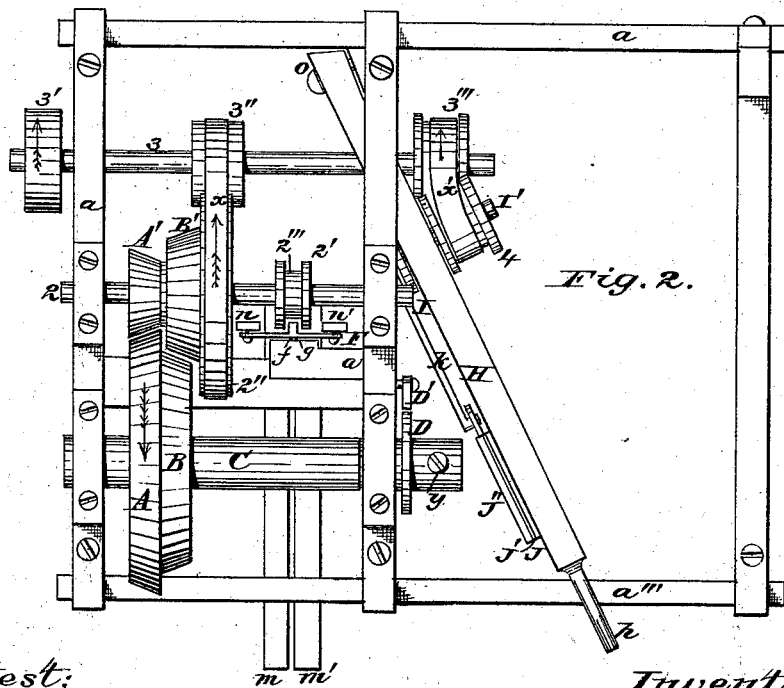
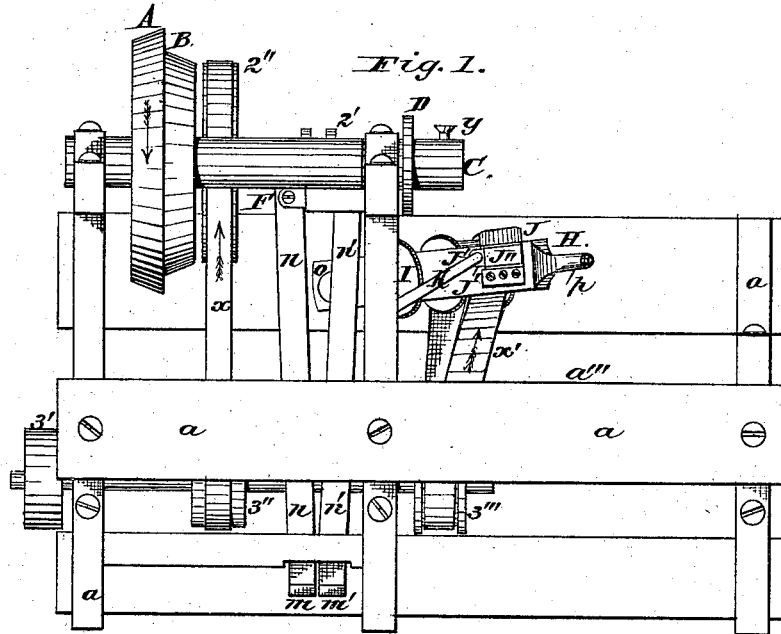

Attest:
G. M. Pawling
H. H. Pawling

Inventor:
W. Davidson Jones

W. D. JONES.
BROOM-WINDING MACHINE.

No. 184,157.

Patented Nov. 7, 1876.

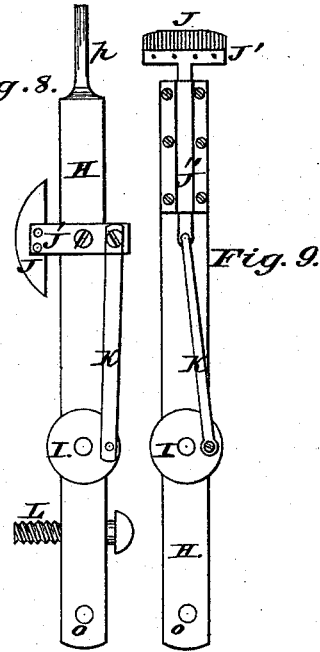
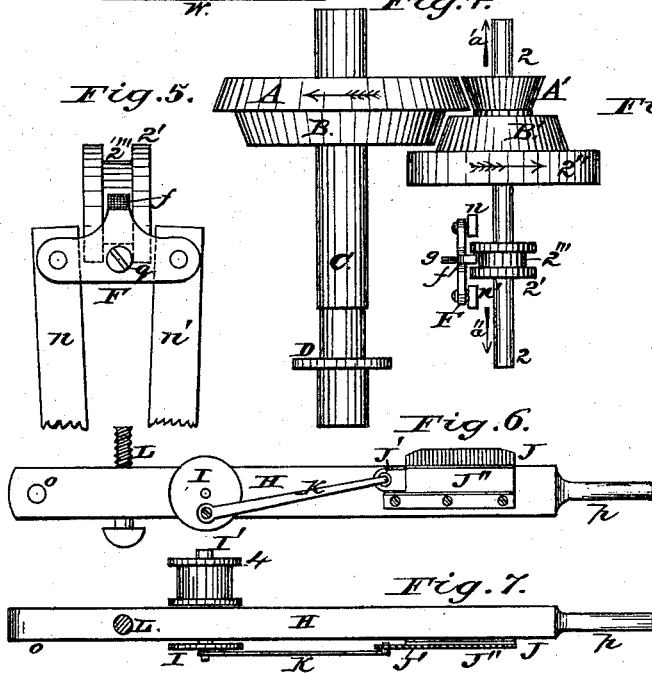
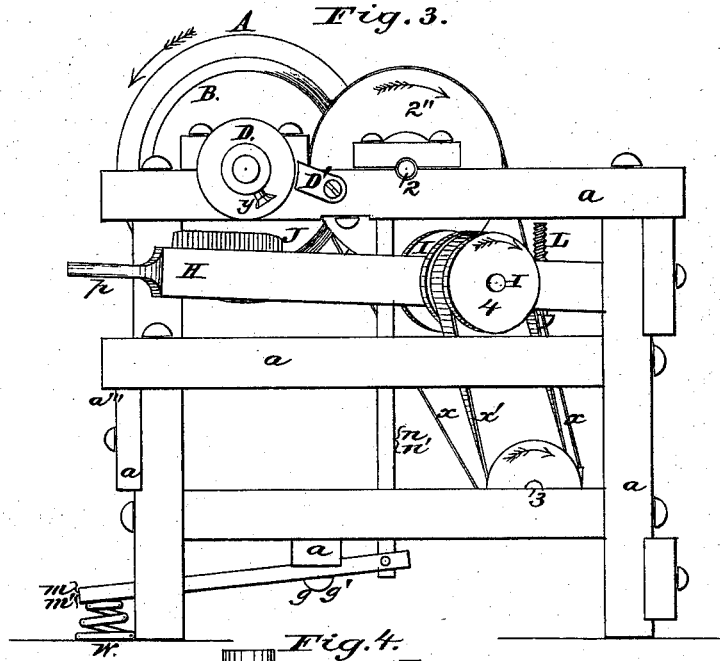

Attest:
G. H. Rawling
H. H. Rawling

Inventor.
W. Davidson Jones

UNITED STATES PATENT OFFICE.

W. DAVIDSON JONES, OF HAGAMAN'S MILLS, ASSIGNOR OF ONE-HALF HIS RIGHT TO CHARLES H. TOLL, OF SCOTIA, NEW YORK.

IMPROVEMENT IN BROOM-WINDING MACHINES.

Specification forming part of Letters Patent No. 184,157, dated November 7, 1876; application filed October 27, 1876.

To all whom it may concern:

Be it known that I, W. DAVIDSON JONES, of Hagaman's Mills, in the county of Montgomery and State of New York, have invented a new and useful Improvement in Broom-Winding or Broom-Making Machines, which improvement is fully set forth in the following specification, reference being had to the accompanying drawings, making part of this specification, in which—

Figure 1 is a longitudinal front elevation, showing the position of the barrel C, with the compound cone-shaped friction-wheels A B thereon, the shoulder-cutting lever H, with the reciprocating cutting device attached, the compound treadles *m m'*, and stems *n n'*, and the counter-shaft 3, with its necessary pulleys and belts. Fig. 2 is a plan, showing the counter-shaft 3, with the necessary pulleys thereon, the cone-shaped compound friction-wheels A A' and B B' on the barrel C, and the shaft 2, treadles *m m'*, stems *n n'*, oscillating shipper F, with projection *f* intersecting the groove in the collar 2'; also, the shoulder-cutting lever H, with the reciprocating cutting device attached thereto, and the necessary belts. Fig. 3 is a transverse elevation of Figs. 1 and 2. Fig. 4 is a sectional plan of the barrel C, the cone-shaped compound friction-wheels, and the shipping device for shipping the shaft 2 lengthwise in each direction, so as to bring in contact the desired pair of friction-wheels, thereby giving two speeds to the barrel C at the will of the operator. Fig. 5 is a sectional elevation of the vibrating shipper F, with its projection *f*, the grooved collar 2', stems *n* and *n'*. Fig. 6 is a longitudinal elevation of the shoulder-cutting lever H, having thereon the crank-disk I, connection K, guide J'', guiding within it the knife-bar J', and knife J attached, and the stop-screw L, all arranged thereon, so as to be susceptible of a vertical movement upon the pivot *o*. Fig. 7 is a plan of Fig. 6, showing the several parts thereof, and the pulley 4, on disk-shaft I', whereby motion is transmitted to the knife J by the belt *x'*. Figs. 8 and 9 are dissimilar plans, of which the shoulder-cutter is susceptible of construction without changing the nature of my invention.

Like letters and figures of reference indicate like parts in each drawing or section thereof, and the arrows the direction of motion.

My invention relates to that class of broom-winding or broom-making machines in which the power to operate the machine may be transmitted and broken from any prime motor—such as steam, water, or horse power—at the will of the operator, thereby obtaining, by depressing with the foot alternately the treadles *m* and *m'*, a quick or slow motion to the barrel C, as may be desired; also, the cutting of the shoulders with a reciprocating knife, or its equivalent, by the elevation of the lever H to its proper position.

To enable others skilled in the art to make and use my invention, I will proceed to describe its construction and operation.

a a a a is a frame constructed substantially as shown in the several drawings. Upon the upper forward part of the frame *a*, (see Figs. 1, 2, and 3,) in boxes, is mounted a hollow mandrel or barrel, C, having thereon the friction-wheels A B and friction-disk D, and screw *y*. Upon the same plane, in boxes, (see Figs. 2 and 3,) is placed the shaft 2, having thereon friction-wheels A' B', pulley 2'', and grooved shipper-collar 2'. The united diameters of friction-wheels A and A' are equal to the united diameters of friction-wheels B and B'. Shaft 2 has a longitudinal movement in its boxes. In boxes in the lower rear part of the frame is placed shaft 3, having thereon driving-pulley 3', pulley 3''', and pulley 3'''. Pulley 3'' and pulley 2'' is connected by the belt *x* that transmits motion to shaft 2, and from pulley 3''' the belt *x'* transmits motion to pulley 4, thereby giving motion to the shoulder-cutter, substantially as shown in Figs. 1, 2, and 3.

The treadles *m m'* are fastened to the under part of the frame by the fulcrums *g g'*, the long parts extending out from under the frame, so as to be reached by the foot of the operator. From the short ends of each treadle, connection is made with each end of the shipper F by the stems *n* and *n'*, all substantially as shown in Figs. 1, 2, 3, 4, and 5. The shipper constructed as shown in Figs. 4 and 5 is pivoted at *p*. (See Figs. 2, 4, and 5.)

H is a lever, extending, from where it is

pivoted at *o*, diagonally forward to the front, where it is provided with a handle, *p*. Within a suitable box in the backward part of this lever is placed the shaft *I'*, having upon one end the crank-disk *I*, and upon the opposite side of the lever the driving-pulley 4. At the forward end is placed a guideway, *J''*, to receive the reciprocating knife-bar *J'*, with knife *J* attached. Connection *K*, from the wrist-pin in disk *I*, connects with the eye of the knife-bar *J'*.

L is an adjustable stop-screw in lever *H*, whose point comes in contact with a portion of the frame, or any suitable projection, so that the knife *J* cannot cut into the handle when cutting the "shoulder" of a broom.

The operation of my invention is as follows: Proper motion is communicated, through the medium of a belt, (not shown,) to the pulley 3', thereby giving motion to shaft 3 and the pulleys thereon. From pulley 3'' the belt *x* transmits motion to pulley 2'' and shaft 2, thereby giving a steady motion to the said shaft with the friction-wheels *A'* and *B'* and collar 2 thereon. The lever *H* is depressed downward, so that the handle *p* may rest upon the frame at *a'''*. (See Figs. 1, 2, and 3.) The belt *x'* will then be slack or loose upon pulley 3'''. Consequently the shoulder cutting device will have no motion. The spring *W* holds treadles *m* and *m'* on the same plane, (see Fig. 3,) thereby relieving friction-wheels *A'* and *B'* from contact with friction-wheels *A* and *B* on barrel *C*. Consequently the barrel *C* will not revolve. The operator places a handle in proper position in the barrel *C*, and secures it with the screw *y*. The wire or cord to wind the broom with is brought forward and fastened to the end of the handle, as is usually done, while the balance of the wire or cord is retained on a spool or drum, and the tension obtained by friction, which arrangements are so well understood by those skilled in the art of broom-making that it is unnecessary to exhibit or describe the same. The operator takes a suitable quantity of corn-brush and places it in proper position, so that the wire or cord can engage it against and around the handle. With his foot he presses down treadle *m*, which elevates stem *n*, and the corresponding end of the shipper *F*. Simultaneous with this movement the projection *f* on the upper part of the shipper *F*, which engages the groove in the collar 2', carries the shaft 2 in the direction as indicated by the arrow *a''*, (see Fig. 4,) thereby bringing friction-wheel *A'* in contact with friction-wheel *A* on the barrel *C*, which gives motion, by the friction thereof, to the barrel *C*, holding the handle and spinning on the wire or cord on and around the brush and handle. (Also, by the same depression of the treadle *m*, the opposite end of the shipper *F* is depressed, carrying with it the stem *n'*, and elevating the outer end of treadle *m'*.) When sufficiently wound, he releases his foot from the treadle *m*; the spring *w* under the treadles (see Fig. 3) elevates treadle *m*, and simultane-

ously the treadles fall until they meet upon the same plane, in consequence of their connection through the stems *n* and *n'* and shipper *F*. As soon as the pressure is released from treadle *m* the shaft 2 moves in the direction as indicated by the arrow *a'*, (see Fig. 4,) which releases friction-wheel *A'* from wheel *A*, thereby stopping the barrel *C*. Friction-pawl *D'* engages wheel *D* on the barrel *C*, thereby not allowing it to revolve backward by the tension of the wire or cord.

The operator then takes a sufficient quantity of brush to form one of the shoulders of the broom, and holds it under the wire or cord, and against the brush just wound on the handle in a proper position, which is well known to the art, depresses the treadle *m* with his foot for a short period of time, giving the barrel a partial revolution, thereby winding on the shoulder just placed. He then takes an equal quantity of brush for the opposite shoulder, places it on the opposite side of the handle and under the wire or cord, as above stated, depresses treadle *m* a short period of time, which gives the barrel another partial revolution, winding on the shoulder just placed. The operator then elevates the lever *H* by the handle *p*, thereby tightening the belt *x'*, which gives rapid motion to pulley 4, crank-disk *I*, connection *K*, and the reciprocating knife *J*; a short continuation of the elevation brings the stop-screw *L* to its projection, and the edge of the knife through that portion of the shoulder between it and the handle. He then depresses the treadle *m* for a sufficient time to revolve the barrel once. The rapid motion of the reciprocating knife, during the revolution of the barrel, cuts off the surplus material to the handle upon the angle it is set in the machine, thereby finishing the shoulders. The operator then depresses the lever *H* to *a'''*, which releases the tension of the belt *x'* and stops the motion of the knife. He then depresses the treadle *m*, and guides with his hand the wire or cord from off the shoulders onto that portion of the handle, where he spins on the hurl or final covering of the broom. On many brooms the final covering is wound with many layers of wire or cord, and to expedite the winding of such successive layers, the operator depresses treadle *m'*, which elevates stem *n'* and that end of the shipper *F*, thereby moving shaft 2 in the direction, as indicated by arrow *a'*, which movement brings friction-wheel *B'* in contact with friction-wheel *B* on the barrel *C*, which gives a greater speed to the barrel and winds the excess of wire or cord on the broom in less time. The two speeds of the barrel *C* is obtained by the different diameters of the driving compound friction-wheels on shaft 2, being brought by the end movement of said shaft in contact with their relative driven compound friction-wheels on the barrel *C*.

It is evident that a device, substantially as shown in Fig. 8, having connection *K*, from the crank-disk *I*, attached to the lower end of

the oscillating knife-bar *J'*, and knife *J* attached to its upper end, and the belt tightened by elevating the lever *H*, will accomplish the same results without changing the nature of my invention; also, the device, as shown in Fig. 9, having the knife *J* on the end of the knife bar *J'*, and the lever *H* set at an angle to the broom-handle, so as to cut or chisel the desired angle of shoulder, and elevating the lever *H* bodily by a pivot through hole *o*, or by swinging the lever *H* out under the broom-handle on a pivot in hole *o*, thereby tightening the belt; will also produce like results; but the one first above described is preferable.

The cutter *J* may have a serrated sickle or uneven edge, but a smooth cutting-edge is preferable.

The lever *H* may be set at any angle required to cut the shoulders, or it may be set at a right angle to a line of the barrel *C* without changing the nature of my invention.

With this invention brooms can be wound and their shoulders cut with great perfection and rapidity. It secures to the operator the full use of his hands to manipulate the corn-brush, wire, or cord, and relieves him of a

great portion of that fatiguing labor which is necessary to operate a hand-broom machine.

What I claim as my invention, and desire to secure by Letters Patent, is—

1. In a machine for winding brooms, the combination of the hollow broom-mandrel *C*, gears *A A' B B'*, collar *2'*, shipper *F*, treadles *m m'*, stems *n n'*, projection *f*, and sliding shaft *2*, substantially as described.

2. In a broom-winding machine, a reciprocating shoulder-cutter, *J*, on the lever *H*, in combination with the rotating broom-holder *C*, whereby the shoulder of a broom may be cut at any desired angle, substantially as and for the purposes set forth.

3. In a broom-winding machine, the combination of the lever *H*, crank-disk *I*, shaft *I'*, connection *K*, guideway *J''*, cutter-bar *J*, and cutter *J*, arranged and operating substantially as herein set forth.

4. In combination with the lever *H*, the adjustable stop *L*, as and for the purposes substantially as shown and described.

W. DAVIDSON JONES.

Witnesses:

WM. M. PAWLING,
H. H. PAWLING.