

F. W. FREUND.
BREECH-LOADING FIRE-ARM.

No. 184,202.

Patented Nov. 7, 1876.

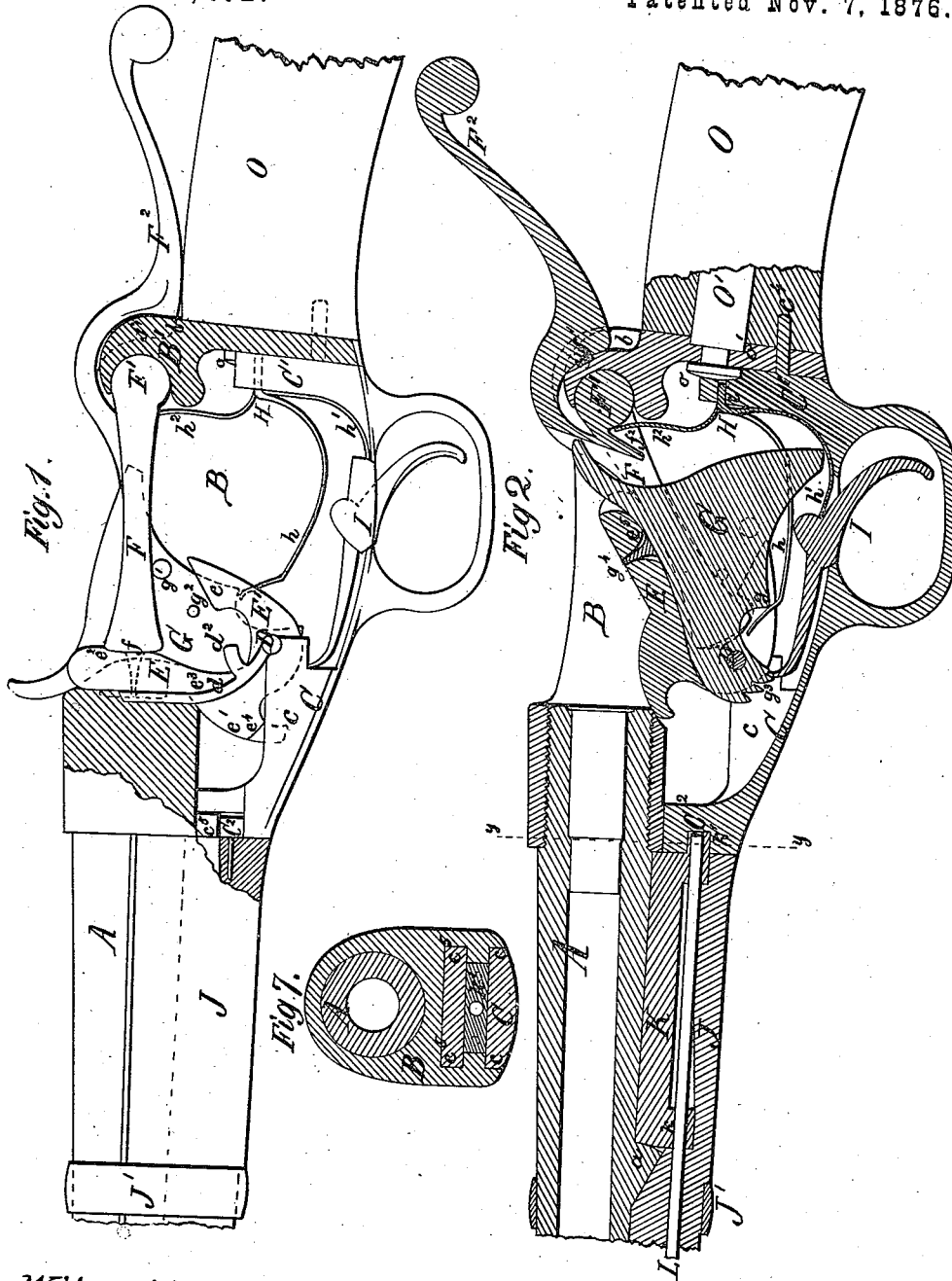

Witnesses:
James Martin Jr.
J. D. Theodore Lang

Inventor:
Frank W. Freund
by
Mason Hewick Burrill

F. W. FREUND.
BREECH-LOADING FIRE-ARM.

No. 184,202.

Patented Nov. 7, 1876.

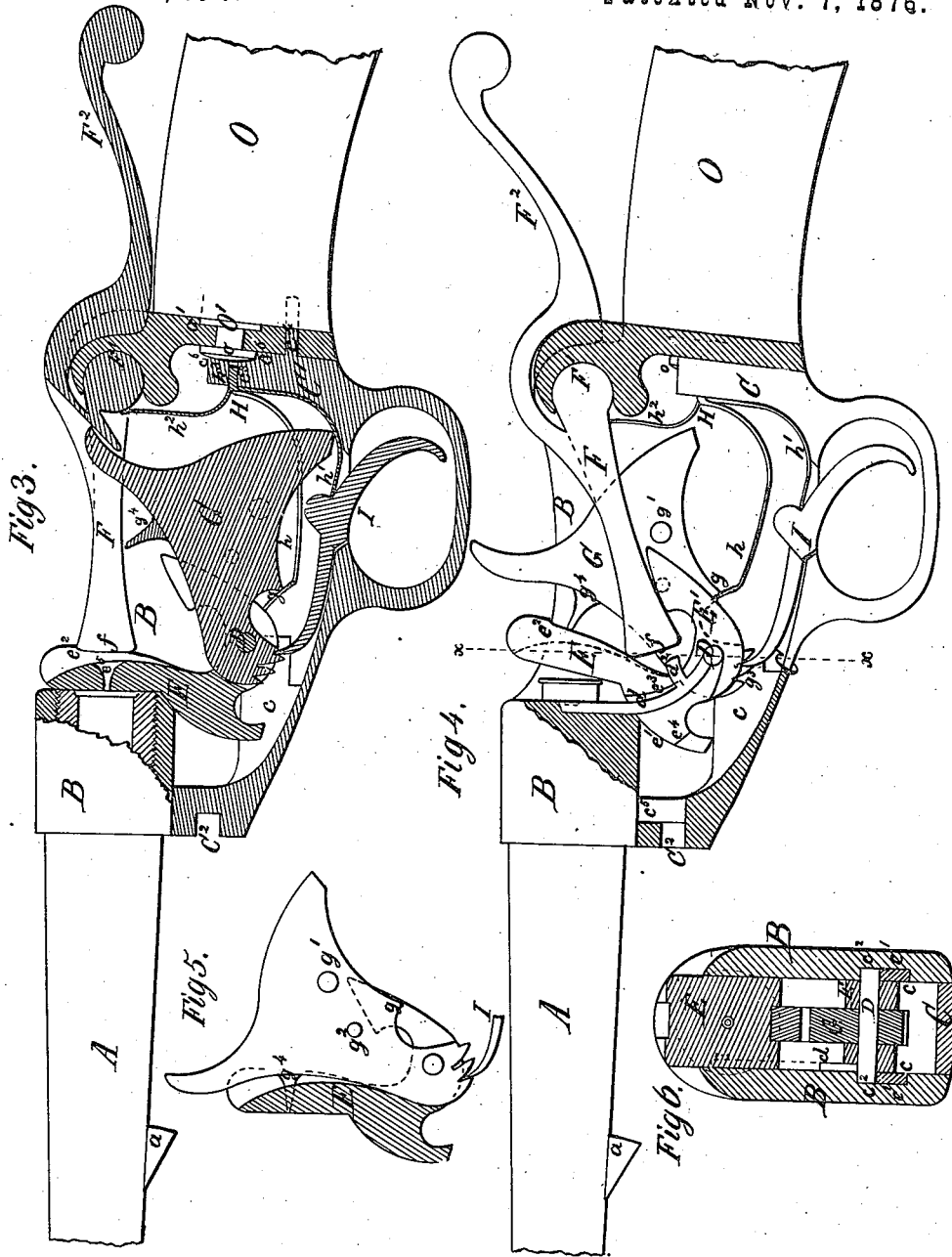

Witnesses:
James Martin Jr.
J. P. Theodore Lang

Inventor:
Frank W. Freund
 by
Mason Howard Lawrence

F. W. FREUND.
BREECH-LOADING FIRE-ARM.

No. 184,202.

Patented Nov. 7, 1876.

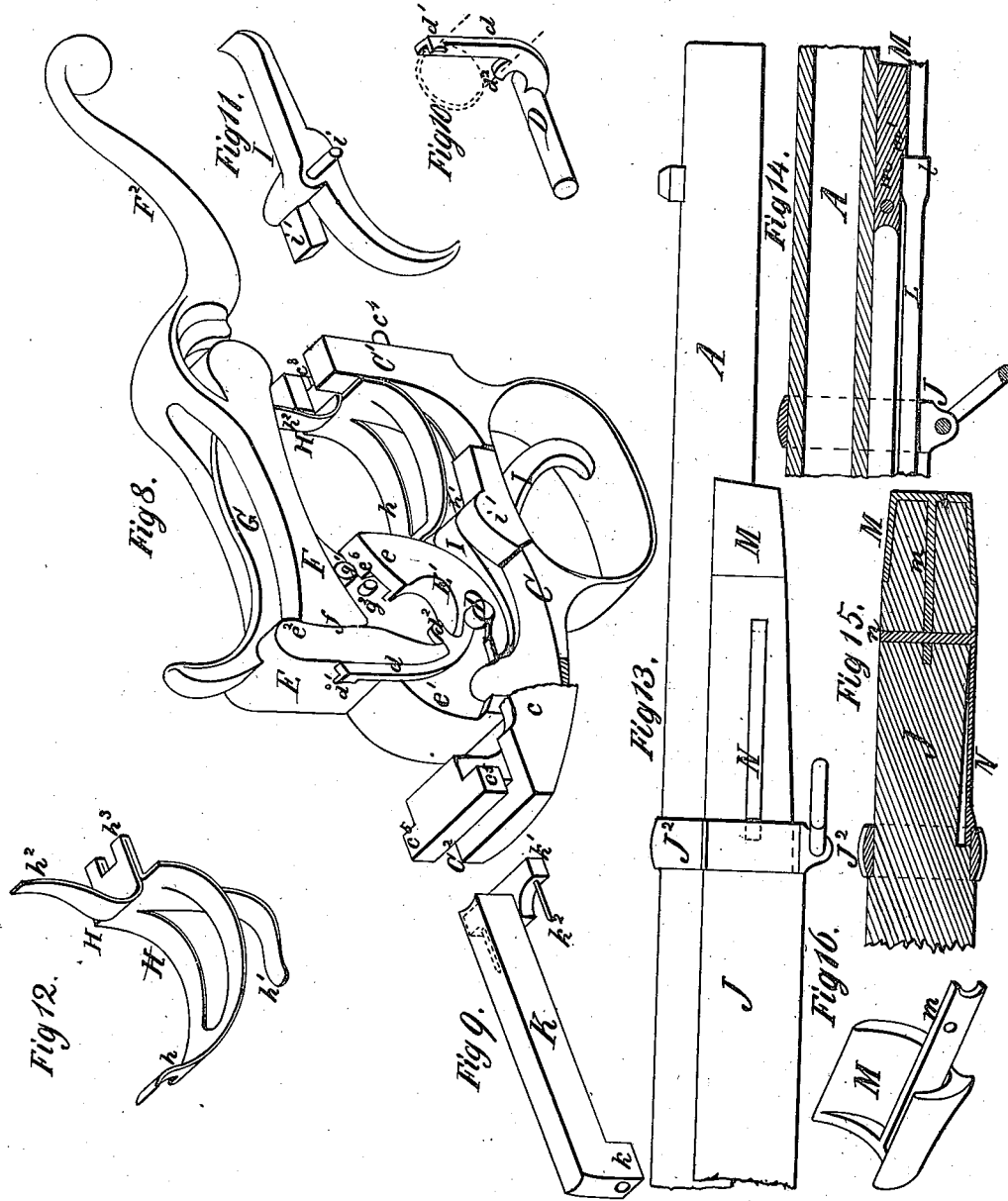

Witnesses:
James M. ...
J. P. Theodore Lang

Inventor:
Frank W. Freund
by
Mason Fenwick Lawrence

F. W. FREUND.
BREECH-LOADING FIRE-ARM.

No. 184,202.

Patented Nov. 7, 1876.

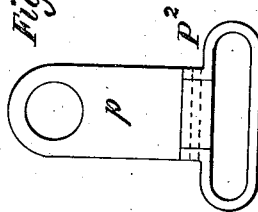
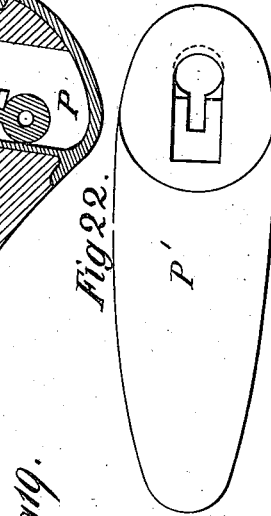
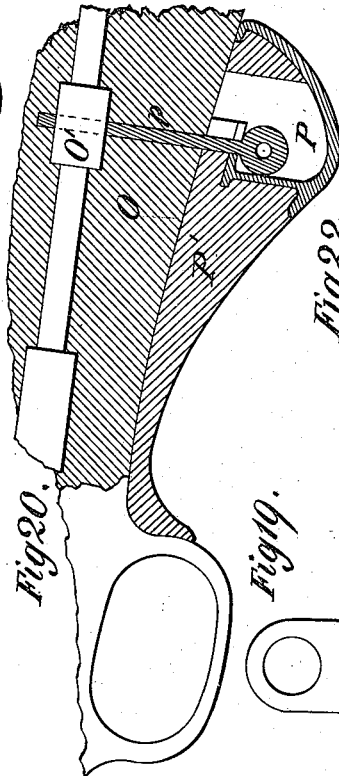
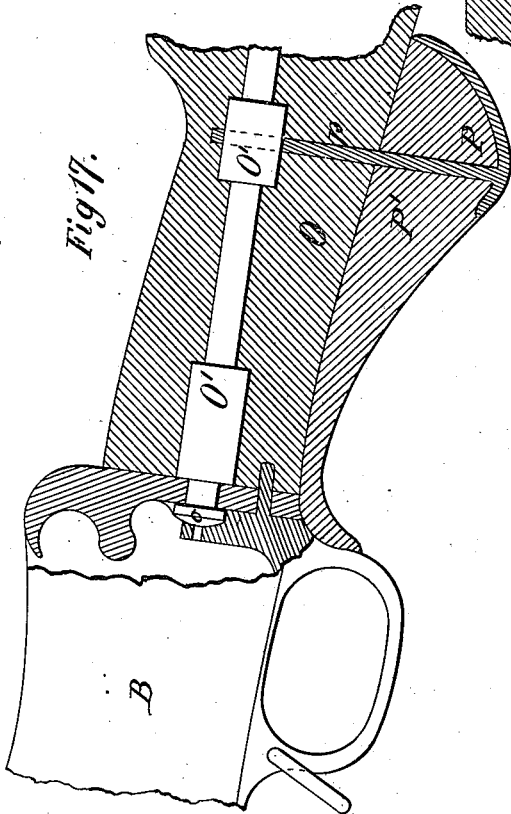
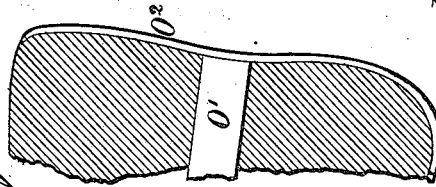
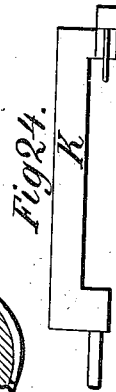
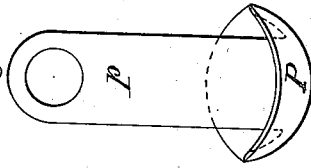
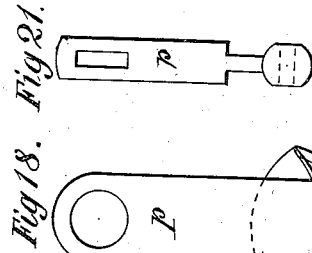
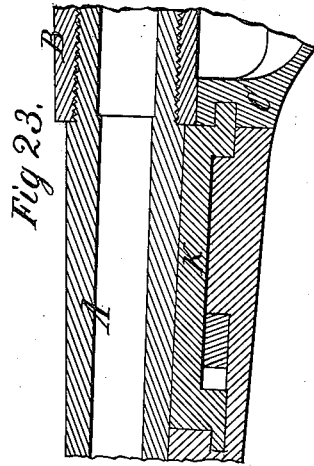

Witnesses:
James Martin Jr.
G. F. Theodore Lany

Inventor:
Frank W. Freund
by Edward S. Hume

F. W. FREUND.
BREECH-LOADING FIRE-ARM.

No. 184,202.

Patented Nov. 7, 1876.

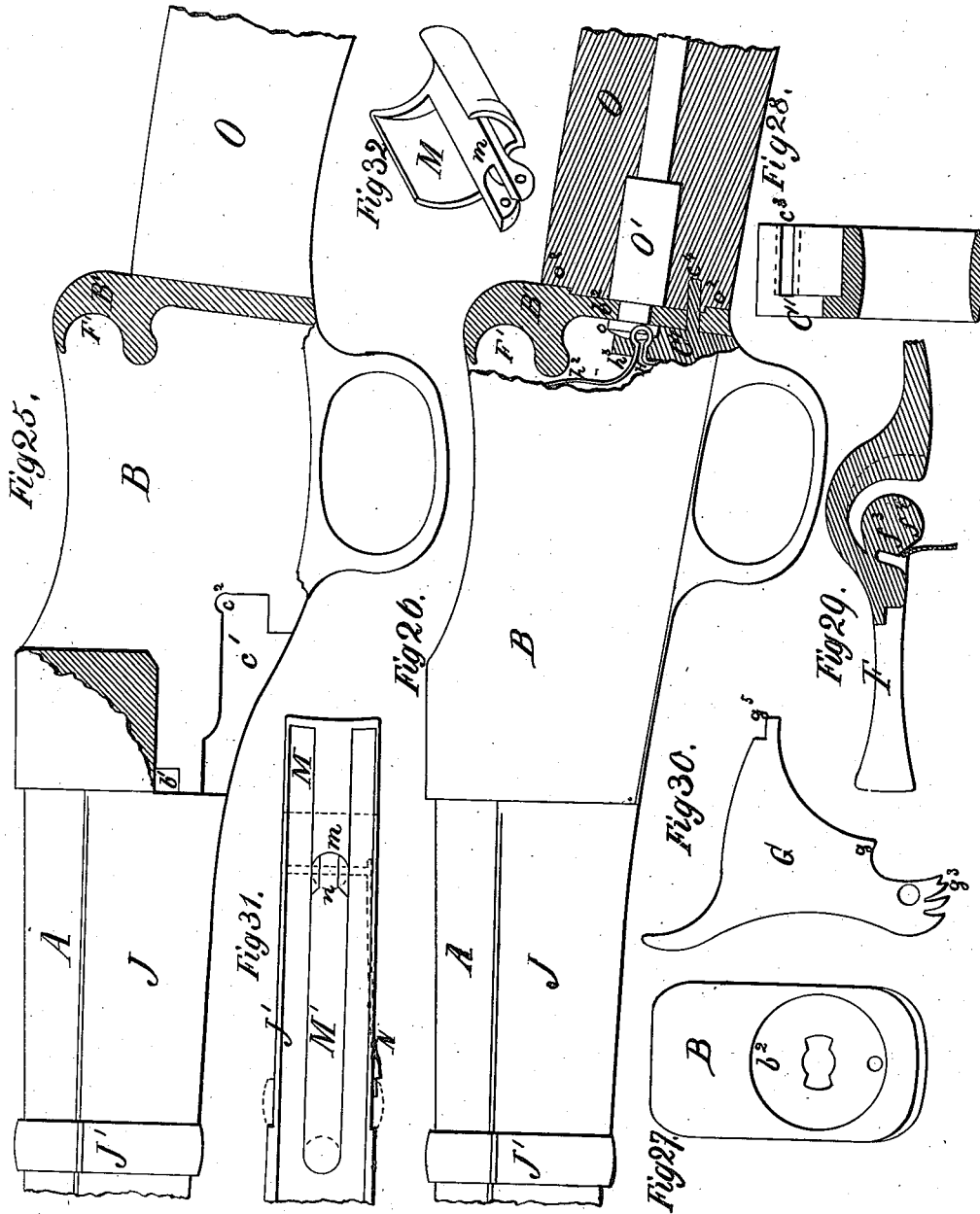

Witnesses:
James Martin Jr.
J. P. Theodore Lang

Inventor:
Frank W. Freund
Mason Fenwick

F. W. FREUND.
BREECH-LOADING FIRE-ARM.

No. 184,202.

Patented Nov. 7, 1876.

Fig 35.

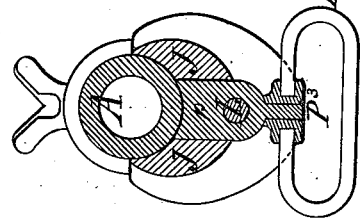

Fig 37.

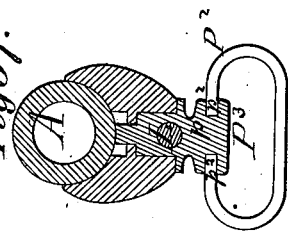

Fig 34.

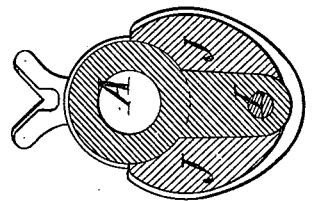

Fig 33.

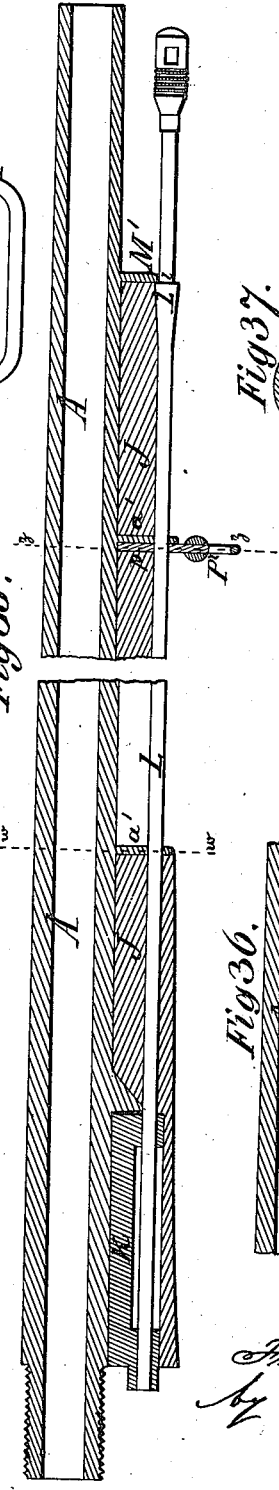
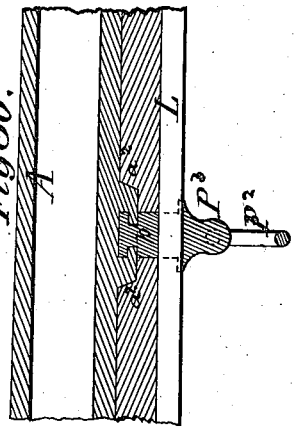

Fig 36.



Witnesses:
James Martin Jr.
J. P. Theodore Lang.

Inventor:
Frank W. Freund
by Mason Smith

UNITED STATES PATENT OFFICE.

FRANK W. FREUND, OF CHEYENNE, WYOMING TERRITORY.

IMPROVEMENT IN BREECH-LOADING FIRE-ARMS.

Specification forming part of Letters Patent No. 184,202, dated November 7, 1876; application filed May 11, 1876.

CASE B.

To all whom it may concern:

Be it known that I, FRANK W. FREUND, of Cheyenne city, in the county of Laramie and Territory of Wyoming, have invented new and useful Improvements in Breech-Loading Guns, which improvements are fully set forth in the following specification, reference being had to the accompanying drawings, in which—

Figure 1 is a vertical longitudinal section and partial side elevation of my improved gun, showing the operating parts as they appear directly after firing the gun. Fig. 2 is a longitudinal vertical central section of the said gun with the breech fully open for the purpose of loading. Fig. 3 is a similar section of the operating parts behind the breech, with the breech closed for firing and the hammer at "full cock." Fig. 4 is a vertical longitudinal section and partial side elevation of the operating parts, showing the hammer at half-cock and the breech partly closed, and a portion of the cartridge outside of the breech-chamber. Fig. 5 is a detailed view of the hammer and the breech-piece, with the hammer in the first notch. Fig. 6 is a cross-section in line *xx* of Fig. 4; and Fig. 7 is a similar section in the line *yy* of Fig. 2, illustrating the formation of the frame for receiving the several movable parts. Figs. 8 and 9 are perspective views of the operating parts removed from the breech-frame, and in the position they are shown as occupying in Fig. 1. Figs. 10, 11, and 12 are detailed views of operating parts. Figs. 13, 14, 15, and 16 are views of front portions of the stock and fastenings thereof. Fig. 17 is a sectional view of the hind portion of the stock provided with a pistol-grip. Fig. 18 is a back view of the pistol-grip fastening. Fig. 19 is a strap-holder made interchangeable with the detachable pistol-grip. Fig. 20 is a modification in section of the pistol-grip shown in Fig. 17. Fig. 21 is a back view of the fastening of the pistol grip or strap. Fig. 22 is a top view of the detachable pistol-grip. Figs. 23 and 24 are illustrations of different modes for fastening the front stock. Fig. 25 illustrates the inside formation of the breech-frame. Figs. 26, 27, 28, 29, 30, 31, 32, 33, 34, 35, 36, and 37 repre-

sent modifications of the several parts of the gun, hereafter more fully described.

The main object of my invention is to furnish a fire-arm in which all the parts of the lock mechanism and other parts composing the arm are interlocked with one another without detachable pins or screws, and secured in permanent position by a final fastening device, which can be operated by hand, and the operating of which fastening device will permit all the parts severally or all together to be detached from the stock or from one another without the use of any tool or instrument.

The nature of my invention consists in certain constructions, combinations, and arrangements of parts, as hereinafter described and specifically claimed, whereby the above-mentioned object is secured, and at the same time a fire-arm of greatly-improved construction produced, said fire-arm being capable of being loaded and discharged with great rapidity, and of being taken apart without tools, such as screw-drivers, and which, owing to its simplicity of construction, can be taken apart and put together by any person in the day or night time without danger of disarranging, breaking, or losing the smaller parts, as with fire-arms of usual construction, said fire-arm also having the number of its separable parts greatly reduced, as the function of many of the respective parts is multiplied, and while all the foregoing advantages are secured the parts, especially of the lock mechanism, may be made cheaper and more durable.

To enable others skilled in the art to understand my invention I will proceed to describe it.

In the accompanying drawings, A represents a gun-barrel fastened to a breech-frame, B. The said breech-frame is mortised for the reception of a trigger-plate, C, and all the other parts necessary for the operation of loading and firing the gun. The trigger-plate C is provided with flanges *c*, which fit into depressions *c'*, Figs. 6 and 25, in the sides of the breech-frame, and the extremities of which form a part of the bearings *c''* for the shaft D of the shell-retractor *d*. The said shaft D sup-

ports the vertical breech-piece E, which is locked by the horizontal breech-locking piece F when the gun is to be fired. The breech-piece E is provided with crescent-shaped levers E', ending with wedge-shaped ends e, by means of which it is turned off the breech of the gun, when the breech-locking piece F descends upon them. A cylindrical shield, e¹, concentric with the shaft D, and bearing against the lower end of the breech, prevents dust or anything else from entering the space below. The back surface of the breech-piece E is so shaped as to form a bearing for the front ends f of the breech-locking piece F in its ascent, and a small step, e², serves as a check for the said motion. Through this construction the ascending motion of the breech-locking piece F causes the breech-piece E to rise and close the breech of the gun. The cartridge-shell extractor d is inserted in the front part of the breech-frame B to a depth sufficient to allow the catch d' to rest against the front part of the rim of the cartridge, as seen in Fig. 10. The lower part of the extractor moves in a depression on the side of the breech-piece E, between the shoulders e³ and e⁴, whereby the movements of the shell-extractor are so limited that the shell is removed, after the breech-piece E is sufficiently out of the way to permit the entire removal of the shell. To prevent the shell-extractor from swaying too far backward, it is provided with a lug, d², which comes in contact with the front end f of the breech-locking piece F, when the breech is fully opened, and thus cannot fall against the shoulder e³ on the breech-piece E. The lower part of the breech-piece E is slotted, and the hammer G is inserted into the said slot, so as to have a bearing on the shaft D. The breech-locking piece F is also slotted at its front part to permit the hammer to be moved in the so-formed slot. The breech-piece F has a semi-cylindrical bearing, F¹, in the rear abutment B' of the breech-frame, and is, when the breech is closed, directly in line with the center line of the gun-barrel. A handle, F², is constructed upon the upper part of the breech-locking piece F, whereby it is operated. The said breech-locking piece is prevented from slipping out of its bearing toward the front by a concentric rib, f¹, which moves in a corresponding grooved bearing, b, in the abutment B'. The hammer G is provided with a projection, g, upon which the branch h of the spring H bears, and with a firing-pin, g⁴, which enters the breech-piece E through an opening, e⁵, before it strikes the cartridge. The sides of the said hammer are provided with lugs or pins g¹ g², upon which the breech locking piece F bears successively in its descent, thereby forcing the hammer back until it arrives at the third rest. To enable the pins g² to move beyond the arms E¹ of the breech-piece E the said arms are provided with grooves e⁶, through which the pins g¹ may

pass. The spring H is cut from one piece of metal, thereby forming three branches, one, h, having the second branch h¹ cut out from its center and bent down to operate the trigger I, while the end of the branch h is made to operate the hammer. The third branch h² is bent upward, and extends into an eccentric cavity, f², in the breech-locking piece F, and, by bearing on the eccentric surface therein, keeps the said breech-locking piece steady in its lower position. The said branch h² is an extension of the main or wider part of the spring which operates the hammer, and it is at the junction with the same doubled up, so as to form a strong double plate, h³, which is inserted into the notch e³ in the upright end C¹ of the trigger-plate, thereby keeping the combined spring H in position. The hammer G is provided with three notches or rests, the first one of which keeps the hammer in such a position as to prevent the firing-pin g⁴ touching the cartridge, as is illustrated in Fig. 5 of the drawings. The second rest is equivalent with half-cock, and the third rest is used previous to the firing of the gun.

The trigger I is provided with a fulcrum-pin, i, which is inserted into the trigger-plate in a lateral direction. The trigger being in the center of the trigger-plate, the vacant room of the opening in the said trigger-plate is covered by a wing, i', on the trigger. The rear end C¹ of the trigger-plate is provided with a pin, e⁴, which is inserted into the back wall of the breech-frame, thus preventing any vertical movement of the rear end of the trigger-plate. The front end of the trigger-plate is provided with a transverse groove, C², and two projections, e⁵, which fit into corresponding recesses b¹ in the breech-frame, and thereby prevent a vertical movement of the front end of the trigger-plate. The front stock J is provided with a wedge, K, which has two heads, k k', through which the end of the cleaning-rod L is passed, to keep the wedge in place. The rear head k' is made to fit the groove C² of the trigger-plate, and it is provided with pins k², which are inserted into the stock, thereby firmly uniting stock and wedge. The wedge K, when in its normal position, rests against the lower part of the gun-barrel, and is between the breech-frame and a lug, a, on the gun-barrel, thereby keeping the front stock from moving forward or backward. A band, J¹, may be used to insure a tight fit between the front stock and gun-barrel. Near the muzzle of the gun the front stock is provided with a metal cap, M, which has a shank, m, through which the pin n of the band-spring N is passed, thus holding it in place. The cap M is provided with a step, m', which bears against a shoulder, l, of the cleaning-rod L, and thereby keeps it in place. A band, J², keeps the front part of the front stock in close contact with the gun-barrel. The rear stock O is attached to the rear part of the breech-frame by means of a T-head,

o, which is inserted by turning the stock at a right angle to its normal position, and which is locked by then turning the stock to its right position. To prevent the stock from turning, the back end C¹ of the trigger-plate is provided with a vertical notch, c², into which the head o fits only in its normal position, and the pin c⁴ on the trigger-plate is made so long as to enter into the stock.

The rod O¹, on which the head o is formed, and to which the butt end is fastened, projects a little beyond the stock, and the said projection fits into a recess, o¹, in the rear end of the breech-frame, as seen in Figs. 2 and 3, thereby steadying and strengthening the connections of the breech-frame and rear stock against torsional strains. The rod O¹ may also serve as a key for keeping a shank, p, of a cap, P, for a pistol-grip, P¹, in place, as seen in Fig. 17, and shown in detail by a front view of the cap in Fig. 18. I may also, in the same manner, attach a strap-holder, P², to the rear stock, as seen in Fig. 19, or make both the pistol-grip and strap-holder exchangeable. The rear end of the rod O¹ is fastened to the butt-plate O², and is thereby prevented from turning.

Operation: The handle F² of the breech-locking piece F is raised, whereby the breech-locking piece F becomes lowered and strikes the pins g¹ of the hammer G. The hammer now is moved back, and the breech-locking piece F then strikes the pins g² and the points e of the breech-piece E, which now is turned off the breech, while the hammer is moved into the third rest. When the movement of the front breech-piece E is nearly completed its lower projection e⁴ strikes the retractor d, thereby moving the cartridge-shell of the previous charge from its seat in the gun-barrel. After the said cartridge-shell is removed the new charge is inserted into the gun-barrel, the breech-piece F in the meantime being kept in its lowered position by the pressure of the spring h² on its eccentric bearing f². While the new cartridge is being inserted its rim comes in contact with the catch d¹ of the retractor, and takes it along until they both arrive at their normal position. The breech-locking piece F in its lowered position, which is represented by Fig. 2, serves to steady the breech-piece E and the retractor d by being in contact with the inner surface of the breech-piece E, and by checking the further progress of the lug d² of the retractor d. The handle F² is now depressed, and the front part f of the breech-locking piece F moves up, bearing against the inner surface of the breech-piece E, which is thereby swung back upon the breech of the gun, thus closing it. The gun is now ready for firing; but, if not desired to fire, the hammer may be moved to the first or second rest. The second rest may be used when the operator wishes to remove the breech-piece E and partly retract the cartridge, in order to give warning and show that the gun is loaded, as is illustrated by Fig. 4.

Manner of taking the above-described gun to pieces without the aid of screw-driver, punch, drift, or wrench: The cleaning-rod with its shoulder is sprung over the step formed by the front cap of the stock, and then removed. The front band and the rear band are then removed, and the stock taken off the barrel by swinging it first from the muzzle until the lug a is cleared, and then freeing it from the breech-frame. The hammer is then moved into the third rest and the breech opened. The trigger-plate is now moved forward until its flanges c have cleared their lower bearings and the pin c⁴ has left the breech-frame, when it is bodily, with the hammer, front breech-block, spring, and trigger, taken out of the breech-frame in a downward direction. The retractor is then removed from the hammer and front breech-block, and the said three pieces are all thereby separated. The trigger is now removed from its bearing by pulling it out sidewise. The mainspring is now removed by pushing its shank h³ out of its bearing. The rear breech-block is then swung as far into the breech-frame as it will go, and pushed over its outer bearings, whereby it becomes detached, and the cleaning-rod L is next removed from stock J. The wedge K is then removed from the stock J. The rear stock O is now turned at a right angle to its normal position and pulled from the breech-frame. By pushing the rod O¹ back this rod and the butt-plate attached thereto may be separated from the rear stock. Thus all of the detachable pieces are separated from their connections except the barrel and frame, and the gun in all its parts can now be cleaned and oiled.

The barrel should never be unscrewed from the frame, except by a skilled workman, as the threads would be worn thereby, and thus allow oscillation upon firing. If the frame and barrel should rust together, so as to virtually form one piece, all the better.

The barrel and frame are made in separate pieces for the convenience of case-hardening the frame, (which is necessary to prevent rust and the wearing of the orifices necessary to receive the journals of the several parts, and also to prevent expansion at the moment of firing,) while the barrel remains of softer material.

I may, however, unite the barrel and frame after case-hardening the latter by soldering, as the solder requires not as much heat for melting as the reduction of the hardening of the frame. This makes the barrel and frame really but one piece, while allowing each its particular and appropriate properties and functions.

The several parts of my invention so far shown and described, are all subject to modifications, of which I have shown several, by means of drawings and the following descriptions: The hammer G, instead of being provided with the pins g¹ g², may be provided with a step, g², as seen in Fig. 30, which is

operated by the breech-locking piece F in a manner similar to the operation above described.

The eccentric surface f^2 on the breech-locking piece F may be substituted by two straight surfaces, f^3 f^4 , as shown in Fig. 29.

The shank h^3 of the spring H may be provided with a cylindrical back, as seen in Fig. 26, which is laterally inserted in a horizontal notch, c^3 , in the end c^1 of the trigger-plate.

The rod O^1 may be flush with the front end of the rear stock, which is then provided with a circular step, O^2 , fitting in a corresponding depression, b^2 , in the breech-frame, or vice versa, the former case being illustrated by Figs. 26 and 27.

In Fig. 26 I have shown the breech-frame with a more straightened outline below, which I prefer to that shown in Fig. 25, and Figs. 1, 2, 3, 4.

The cap M, shown in Fig. 32, has a slotted shank, m , into which slot the stepped head m^1 of a metallic bearing, M^1 , for the cleaning-rod may be inserted, and thereby conjointly fastened to the stock by means of the pin of the band-spring.

Fig. 24 represents a modification of the wedge K in the front stock. Fig. 23 shows a modification of the manner of fastening the front stock to the breech-frame. Fig. 20 illustrates a pistol-grip detachable, and locked by a trigger-guard. Fig. 21 shows a strap-holder exchangeable for the pistol-grip. Fig. 22 is a top view of the removable pistol-grip, the cap P being removed to exhibit the shape of the mortise into which the separate shank p is inserted. In Figs. 33 and 34 is shown a mode for effecting the attachment of the front stock to the barrel by means of lugs a^1 , which are fastened on the barrel, and are inserted into the stock, the cleaning-rod L passing through them and the stock, and thereby securing them together. The lug M^1 serves in the capacity of the cap M, shown in Fig. 16. For the application of a strap-holder a plate, p , is provided. This plate is perforated for the passage of the cleaning-rod L, and has a swiveled head, P^3 , for the reception of the strap-holder proper, as shown in Fig. 35, by a cross-section in the line $z z$ of Fig. 33. This plate is inserted in the stock J wherever convenient. The swivel-head P^3 has a socket, p^2 , at each end, wherein the ends of the strap-ring p^3 are sprung.

I have shown another mode of fastening the front stock to the barrel by a longitudinal section in Fig. 36, and by a central cross-section in Fig. 37. The barrel in this case is provided with overlapping lugs a^2 , forming a T-shaped groove, into which the foot of the shank p of the strap-holder is inserted and locked thereto by a so-called bayonet-fastening. The head of the said shank has a broad rim, whereby it keeps the stock close to the barrel. The cleaning-rod is passed through the said shank,

and thereby prevents it from turning and being unlocked.

The handle F^2 of the horizontal breech-locking-piece F may be so attached as to be operated on the side. This handle F^2 may be constructed separately, and attached to the locking-piece F, especially if the lock mechanism should be arranged to be operated from the rear, for which latter I intend to apply for separate Letters Patent.

In the gun represented I have shown the two sights fastened permanently to the barrel; but I intend to show in another application for a patent a detachable sight, which may be removed upon the removal of the front stock.

I have several different forms of raised sights, which are constructed and attached without any separate pin, and which become detachable upon the removal of the front stock, for which I intend to make a separate application for Letters Patent.

I intend, in another application, to show that the second front projection on the barrel may be discarded by attaching the stock to the barrel by the strap-holder alone, as will appear in my proposed applications for patents.

In case persons should prefer and insist upon the old style of band shown at J¹, they can be employed, but I prefer the method hereinbefore described.

Having described my invention, what I claim, and desire to secure by Letters Patent, is—

1. A breech-loading gun mechanism, substantially as described, having its respective parts constructed and arranged to match, support, and hold together one another in such a manner that the use of separate pins, screws, or other similar means of fastening the parts together, is avoided, substantially as herein set forth.

2. A breech-loading gun mechanism and gun-stock, substantially as described, in combination with a single fastening device, whereby said single fastening device is made to serve for securing all the mechanism in place, and by operating it the parts, severally or altogether, may be detached from the stock or from one another without the use of any tool or instrument, substantially in the manner set forth.

3. The breech-piece E, turning on a bearing below the axis of the barrel, the bifurcated brace F, having a bearing, F^1 , at its rear end, in the frame, about on a line with the axis of the barrel, and a central hammer, arranged to strike the cartridge through an opening in the breech-piece E, all combined and operating substantially as set forth.

4. The retractor d , breech-piece E, and the hammer G, combined as shown and described, whereby the pin D serves as a common fulcrum for the several parts.

5. The trigger-plate C, constructed substantially as described, whereby the lock and breech mechanism and the rear stock are secured to their places, substantially as herein set forth.

6. The rib or rear bearing f^1 of the frame, in combination with the breech-locking piece F, provided with a shoulder on an extension of the locking-piece, to prevent forward movement of said locking-piece, as described.

7. The combination of the breech-piece E, the breech-locking piece F, provided with the eccentric inside bearing f^2 , and the spring h^2 , arranged and operating substantially as described.

8. The hammer G, having side pins or projections $g^1 g^2$, in combination with the block F, whereby the hammer is cocked when the breech is opened, and whereby it closes the breech in the act of firing, substantially as herein described.

9. The extractor d , provided with the lug d^2 , the breech-block E, arranged to turn backward on a bearing below the line of the axis of the barrel, and a locking-piece, F, the parts being arranged to operate in relation to each other, substantially as described.

10. The mainspring H, having the branches $h h^1 h^2 h^3$, all being made of one piece of sheet metal, substantially as and for the purpose set forth.

11. The combination of the head o of the rear stock, and the notch o^1 in the rear part C^1 of the trigger plate, whereby the turning of the stock is prevented, substantially as described.

12. The combination of the trigger-plate C, breech-frame B, and the stock O, constructed and operating substantially as described, so that the rear stock is attached and detached from the gun without the use of screws, pins, or keys, substantially as set forth.

13. The trigger-plate C, provided with flanges c , the latter formed with bearing-seats for the shaft D, and with interlocking notches beneath said seats, which interlock with the breech-frame B, whereby the trigger-plate is held with its attachments firmly against vertical movement, substantially as described.

14. The combination of the breech-frame B, having depressions b^1 and c^1 , and the trigger-plate C, having projections c^2 , flanges c ,

and a transverse groove, C^2 , and the wedge K, in the front stock, having the heads $k k^1$, and the barrel A, having an abutment, a , whereby the trigger-plate is secured in its place, and prevented from downward and forward motion.

15. The combination of the band-spring N, having the pin n , and the cap M, having the stem m , whereby the cap M and band J^2 are simultaneously secured to the front stock.

16. The combination of the stock J, the wedge K, the trigger-plate C, and the rod L, substantially as described.

17. The combination of the wedge K, the stock J, and the trigger-plate C, for the purpose of locking and unlocking the trigger-plate, substantially as described.

18. A breech-loading mechanism and stock, substantially as described, in combination with the cleaning-rod, whereby the said cleaning-rod is made the only fastening for securing all the mechanism in place, one part to another, and the whole to the stock, substantially as herein set forth.

19. The wedge K, provided with the pins k^2 , whereby the stock J is prevented from dropping off when the cleaning-rod L is removed, substantially as described.

20. The combination, substantially as described, of the front stock, barrel, and cleaning-rod, so constructed that these parts can be securely attached to each other without bands, or screws, or any similar fastenings, the two former being securely locked together by the cleaning-rod, substantially as described.

21. The combination of the barrel A, having the lugs a' and M^1 , the stock J, and the rod L, substantially as described.

22. The combination of the strap-holder P^2 , the barrel A, provided with a lug, a' , the stock J, and the rod L, substantially as described.

23. In combination with a gun, a strap-holder having a swivel-extension, P^3 , upon that part which is fastened to the barrel or stock, thereby allowing a swivel-movement of the loop attached thereto, substantially as set forth.

FRANK W. FREUND.

Witnesses:

F. THRELL,
L. C. STEVENS.