

S. W. LUDLOW.  
 SPRING-VEHICLE.

No. 184,250.

Patented Nov. 14, 1876.

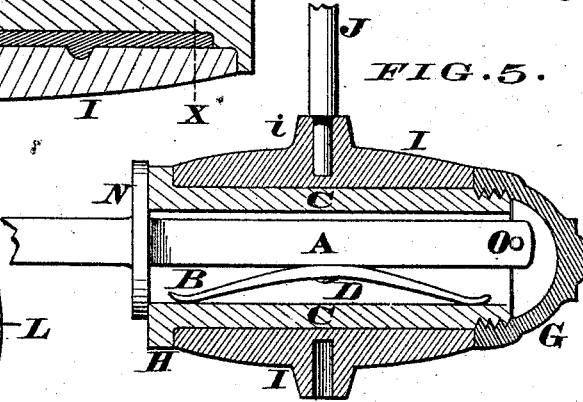
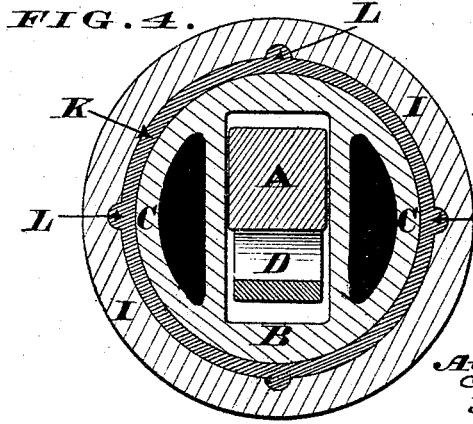
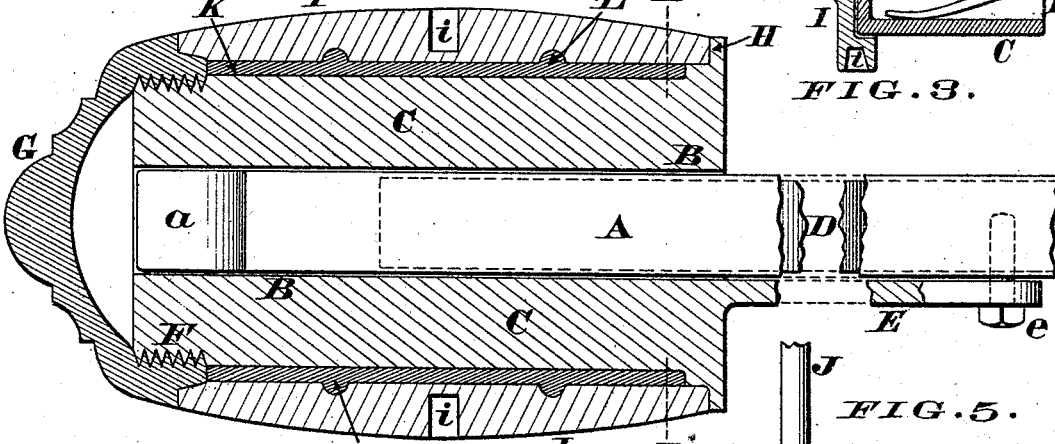
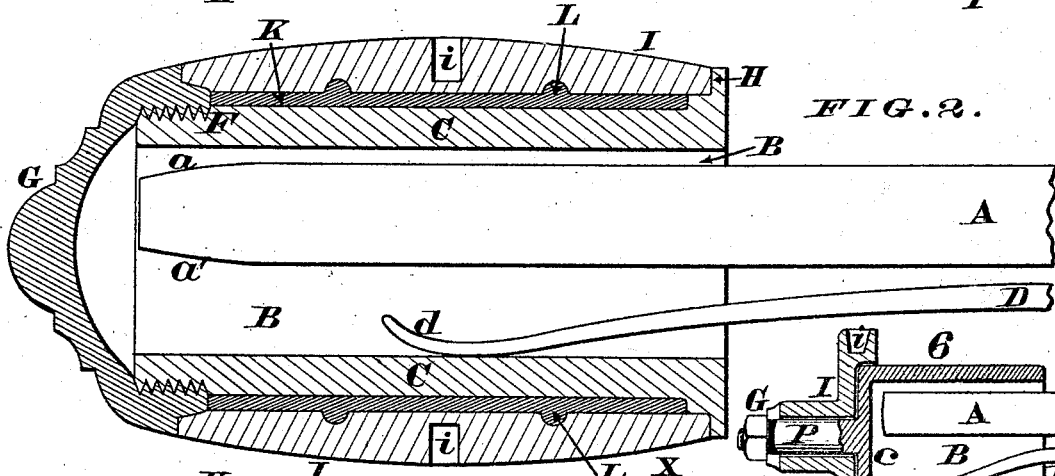
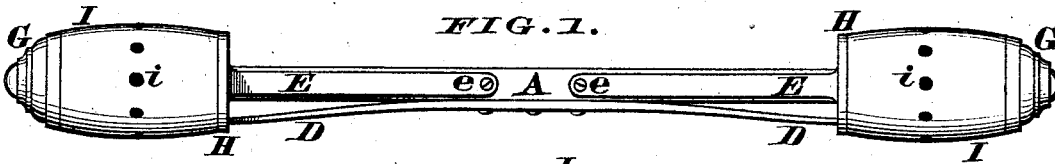

Attest.  
 C. A. Schmidt  
 J. B. Barber

Samuel W. Ludlow.  
 by James H. Layman  
 His Attorney.

# UNITED STATES PATENT OFFICE.

SAMUEL W. LUDLOW, OF CINCINNATI, OHIO.

## IMPROVEMENT IN SPRING-VEHICLES.

Specification forming part of Letters Patent No. 184,250, dated November 14, 1876; application filed May 2, 1876.

*To all whom it may concern:*

Be it known that I, SAMUEL W. LUDLOW, of Cincinnati, Hamilton county, Ohio, have invented certain new and useful Improvements in Spring-Vehicles, of which the following is a specification:

The object of my invention is to enable a carriage or other vehicle to be constructed in such a manner as to dispense with the present complicated and expensive arrangement of springs for supporting the body or bed upon the axles, and I accomplish this result as follows: The hub of each wheel is adapted to revolve freely around a cylindrical box, which latter is slotted longitudinally to receive the non-circular spindle of the axle. This slot is made as capacious as practicable from top to bottom, so as to allow considerable vertical vibration of the spindle within the same. The spindle fits snugly against the sides of the slot, but does not come in contact either with its top or bottom, it being supported within the box by means of a spring, whose fixed end is secured at or near the middle of the axle. The free end of said spring rests upon the bottom of the slot at a point about in line with the spoke-mortises of the revolving hub. Furthermore, this slotted and non-rotating box has projecting from its inner end one or more arms or rods, of any suitable length, which rods are pivoted to the axle in such a manner as to prevent displacement of the hub, while at the same time they allow unrestricted vertical play of the spindle within the aforesaid slot. The rotating hub, which may be lined with a Babbitt or other soft-metal bushing, is retained in its proper position upon the box by a cap screwed to the outer end of the latter, which cap also serves to conceal both the slot and the end of the spindle.

In the annexed drawing, Figure 1 is an elevation, showing a pair of my hubs applied to an axle. Fig. 2 is an enlarged vertical section through one of the hubs and its accessories. Fig. 3 is a horizontal section of the same. Fig. 4 is a transverse section at the line X X. Fig. 5 represents a modification of the invention.

A represents an axle that is square, or approximately square, in its transverse section,

said axle being constructed without the customary conical spindles at its ends; but, in lieu of such spindles, the upper and under surfaces of the axle are beveled off at *a a'*, for a purpose which will presently appear. The end of axle A is adapted to enter the longitudinal slot B of cylindrical box C, which slot is shown as extending completely through the box, although it may stop short of the outer end of the same, if desired. The height of this slot is somewhat greater than its width, in order that the end of axle A may have considerable vertical play within the non-rotating box C. Secured at or near the middle of axle A is a spring, D, composed of one or more leaves, and having its free end *d* arranged to bear upon the bottom of slot B at a point about in line with mortises *i* of rotating hub I. This spring is preferably somewhat narrower than axle A, in order that the latter may sustain all the violent backward and forward strains or concussions of the hub, and thereby prevent any wrenching or twisting of said spring. Each hub may have its individual spring, or a single spring may be provided for the two hubs, mounted upon an axle, as represented in Fig. 1. For the purpose of preventing box C shifting longitudinally of axle A, said box has cast with it, or otherwise rigidly attached thereto, an inwardly-projecting arm or bar, E, of any suitable length. This arm is pivoted to the axle at *e*, and thus acts as a radius-rod to confine the hub B I to its proper relative position to said pivot, while at the same time the axle is free to play vertically. This arm may be duplicated on the opposite side of the axle; but it is preferred to use but one rod for each hub, and to locate it on the inner side of the axle, so as not to be exposed to view. The outer end of box C is screw-threaded at F, to receive a cap, G, which cap not only acts to conceal the end of slot B, but it also serves, in connection with a collar, H, to secure the rotating hub I upon said cylindrical box. This hub is provided with any suitable form of mortises or sockets *i*, to receive the spokes J, which latter may be "staggered," if desired. The hub may be furnished with an internal bushing, K, of Babbitt or other suitable metal, said bushing being anchored into the hub I with projections or ribs L.

In the modified form of my invention (shown in Fig. 5) the end of axle A is represented as supported upon a spring, D, which latter is completely housed within the slotted box. The arm E is omitted from this hub, and its functions are performed by collar N and pin O. As the height of slot B is sufficient to allow for all necessary vibrations of axle A, it is evident that the body of the vehicle will have an easy undulatory motion without being elevated too high, as must be done when the body is perched upon springs above said axle. As there is no reduced or tapering spindle in my axle, it is evident this supporting member of the vehicle is not weakened by the re-entrant angle formed at the junction of the customary spindle with the axle.

The box C, instead of being a solid casting, may be chambered out, as shown in Fig. 4, so as to reduce its weight without impairing its strength or efficiency; or the outer end of said box may be closed with a head, c, having a projecting stud, P, for the hub I to rotate around, as indicated in diagram 6. This arrangement enables me to make the rear end of box C capacious enough to allow considerable vertical vibration of axle A.

I have described this axle as square or approximately square in its transverse section, which is the preferred mode of construction; but it is evident said axle may be hexagonal or octagonal, or circular, or any other shape where it enters the slot B. Finally, the pivots *e* may be dispensed with, and the opposing boxes of a single axle be coupled together with one bar.

I claim as my invention—

1. A carriage-axle, A, supported upon a spring or springs, D, and adapted to have vertical play within slot B of box C, upon which latter or its stud P the hub I is journaled, substantially as herein described and set forth.

2. In combination with axle A, slotted box B C, and revolving hub I, the rod E, either pivoted to the axle at *e* or connecting the two boxes of said axle, substantially as herein described and set forth.

In testimony of which invention I hereunto set my hand.

SAMUEL W. LUDLOW.

Witnesses:

JAMES H. LAYMAN,  
S. B. SPEAR.