

M. C. NILES.
KNOB-LATCH.

No. 184,259.

Patented Nov. 14, 1876.

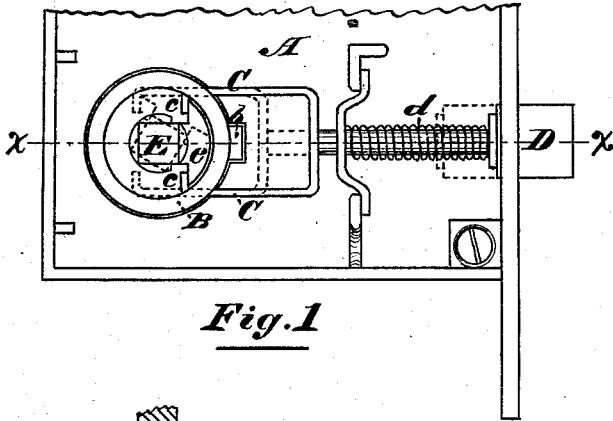

Fig. 1

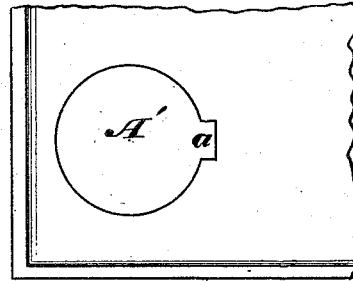

Fig. 3

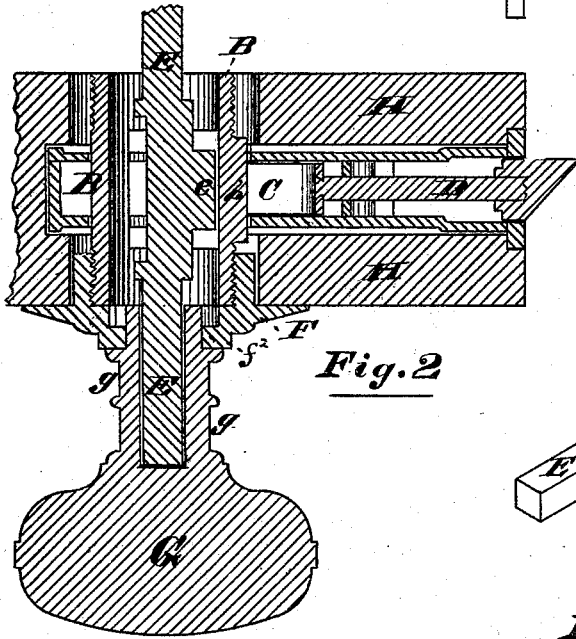

Fig. 2

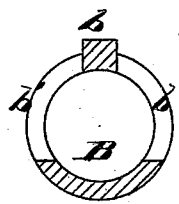

Fig. 5

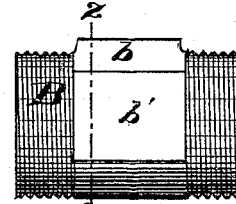

Fig. 4

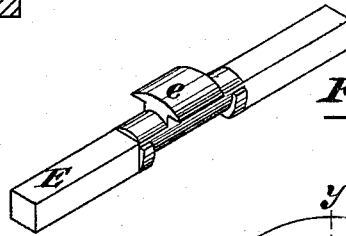

Fig. 6

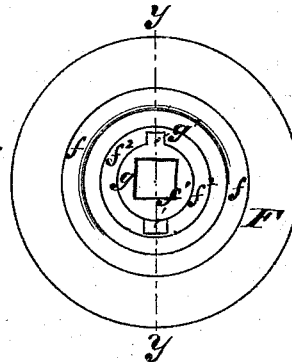

Fig. 7

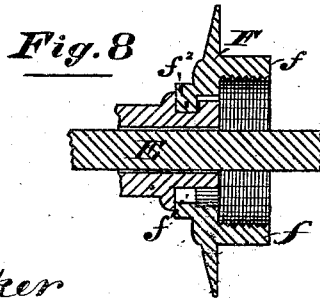

Fig. 8

Attest
W. S. Baker
L. M. Harris

Inventor
Milton C. Niles
By Coburn & Shacher

Attorneys

UNITED STATES PATENT OFFICE.

MILTON C. NILES, OF CHICAGO, ILLINOIS.

IMPROVEMENT IN KNOB-LATCHES.

Specification forming part of Letters Patent No. 184,259, dated November 14, 1876; application filed August 12, 1876.

To all whom it may concern:

Be it known that I, MILTON C. NILES, of Chicago, in the county of Cook and State of Illinois, have invented a new and useful Improvement in Door Knobs and Locks, which is fully set forth in the following specification, reference being had to the accompanying drawings, in which—

Figure 1 represents a plan view of a portion of a lock with the back plate removed; Fig. 2, a sectional view of the lock and knob in place in the door, the section of the lock being taken on the line *x x*, Fig. 1; Fig. 3, a view of one of the lock-plates, showing the form of the holes cut therein for the spindle-tube; Fig. 4, a plan view of the tube; Fig. 5, a cross-section of the same on the line *z z*, Fig. 4; Fig. 6, a perspective view of the spindle; Fig. 7, a back view of the rose and knob attached; and Fig. 8, a cross-section of the same, taken on the line *y y*, Fig. 7.

The object of my invention is to simplify and cheapen the construction of door locks and knobs by dispensing with the usual hub, and operating the bolt directly by the spindle engaging with the talons or catches of the bolt.

The invention consists in a tube extending through the lock, and on each side thereof, so as to receive the roses, and cut away at its central portion to receive the talons of the bolt, which pass within it, and are engaged by a spindle constructed for this purpose, and rotating within the tube; also, in the peculiar construction of the spindle, so that it performs the functions of both the spindle and the usual hub; and also in various combinations of devices, as will be hereinafter fully set forth.

In the drawings, A represents a mortise-lock of ordinary construction, except in the particulars hereinafter named. In the plates of the case round holes A' are cut at the usual places for the reception of the hub; but they are made considerably larger than is necessary for an ordinary hub. A notch or recess, *a*, is also cut in each plate, opening into the holes A'. A tube, B, is passed through the holes A' in the sides of the lock-case, and is secured from turning therein by means of a spline, *b*, which fits in the notches *a* in the plates of the case. This tube B is made of

sufficient length to project beyond the lock on each side, flush, or nearly so, with the two surfaces of the door, and has an exterior screw-thread cut upon each end. The ends of this tube are left entire; but the central portion is cut out on each side of the spline *b*, so as to have large openings *b'* into the interior of the tube, as shown in Figs. 4 and 5 of the drawings. These openings *b'* are arranged so as to permit the talons C to pass into the interior of the tube, as shown in Fig. 1 of the drawings.

The talons are of ordinary construction, except that their ends *c* are bent inward toward each other, instead of outward or to one side, as is usually the case. They are connected to the bolt D in the usual manner. The bolt D is of ordinary construction, and is provided with the usual spring *d*, which forces it outward into its keeper.

The spindle E is constructed in the ordinary manner for the purpose of entering the sockets in the shanks of the knobs; but near its center it is provided with a projection, *e*, cast upon it, the exterior surface of which is convex, with edges projecting somewhat beyond the body, so as to form flanges, as shown in Fig. 6 of the drawings. This piece *e* should be in length about equal to the thickness of the lock, and should be wide enough to engage with the talons C when placed within the tube B, as shown in Fig. 1 of the drawings. The convex surface of the cam or piece *e* is intended to conform to the concave surface of the tube B; but the several devices should be so arranged with reference to each other that there is no contact between the piece *e* and the tube B, by which friction would be produced.

The roses F are constructed with a circular flange, *f*, upon their inner faces, in the interior of which is cut a screw-thread, by means of which the roses are attached to the ends of the tube B. They are also provided with a small notch, *f'*, cut out from the holes in which are inserted the ends of the knob-shanks. The knobs G are constructed with the usual shanks *g*, in which are sockets to receive the ends of the spindle E. At the outer end of the knob-shank *g* is a projection or lug, *g'*, which passes through the notch *f* in the rose, so as to per-

mit the end of the shank to be inserted in the rose, and which securely fastens the knob to the rose whenever the former is turned so as to bring the lug g' behind a flange, f^2 , in the rose F, as shown in Figs. 7 and 8 of the drawings.

In order to attach my improved door-lock and knob to a door, the spindle and tube E should first be removed from the lock-case and the latter placed in the mortise in the edge of the door H, provided for its reception. The tube B is then passed through suitable holes in the door, and through the lock-case, the spline on the tube being slipped into the notches in the lock-plates, so that the tube cannot turn in the case. One of the roses F is then screwed upon one end of the tube B, but not quite turned up against the wood of the door. The spindle E is then passed up through the tube, the bolt D being at the same time forced back so that its talons will be pushed through the openings B' in the tube far enough to permit the cam or projection e to pass behind them into the position shown in Fig. 1 of the drawings. The knob is then put upon the end of the spindle projecting from the rose already attached, and in the end of the knob-shank is inserted in the rose, as described above. The other rose is now screwed upon the other end of the tube B and turned nearly home, and the other knob is attached thereto. The roses should then be turned down tight upon the door, and a half or three-quarters turn having been left when the roses were first attached, the notches f^1 will be carried around so far when the roses are turned down that the lug g' cannot be brought to engage therewith in the limited motion permitted to the knob in reciprocating the bolt. It will be seen from the description that when this spindle is turned slightly, one or the other of the edges of the projecting cam e will engage with and drive back one of the talons of the bolt, and thereby slide the latter, as shown in dotted lines in Fig. 1 of the drawing.

The knobs being secured to the spindle, as described, the latter is turned by them to operate the bolt, and it will be seen that the

spindle E performs the functions both of an ordinary spindle and of the usual hub which operates to slide the bolt.

It will also be seen that there are no bearing-surfaces in either the door or the lock, the bearings of the spindle being the bearings of the knob-shanks in the roses. There is, therefore, very little friction and very little wearing-surface, so that the knob may be turned and the bolt withdrawn with great ease, and there is small opportunity for the loosening of parts by the wearing away of surfaces.

With this improvement the ordinary screws for attaching the lock to the door may be dispensed with, as the lock is securely held in place by the tube B and its attachments.

Having thus described my invention, what I claim as new, and desire to secure by Letters Patent, is—

1. The lock-case A, provided with holes A', in combination with the tube B, having central openings b' , the spindle E, provided with a cam or projection, e , and the bolt-talons C, with the free ends bent inward toward each other, as specified, all constructed, arranged, and operating substantially as and for the purpose set forth.

2. The combination of the lock A, provided with holes A' and notches a , and the tube B, having a spline, b , substantially as and for the purpose set forth.

3. The combination of the perforated lock A, the tube B, constructed with the ends entire, and screw-threads cut thereon, extending through the lock and projecting from each side thereof, the roses F screwed thereto, the spindle E arranged within the tube, and the knobs G, attached to the roses by means of the notch f^1 and the lug g' , substantially as described.

4. The combination of the tube B, spindle E, roses F, and knobs G, constructed and arranged so that the only bearings are those of the knob-shanks in the roses, substantially as described.

MILTON C. NILES.

Witnesses:

LEWIS L. COBURN,
L. M. HARRIS.