

R. W. PARK.

SELF-GENERATING GAS LAMP.

No. 184,261.

Patented Nov. 14, 1876.

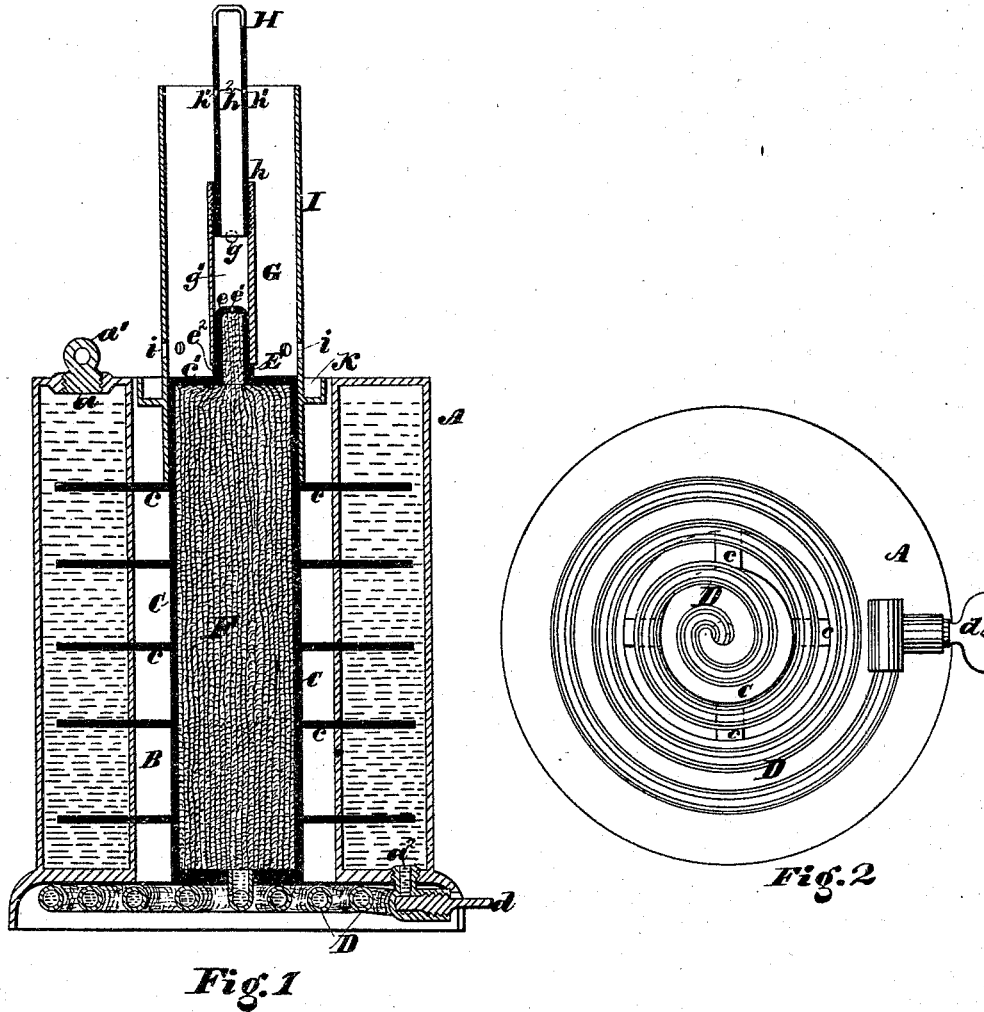

Witnesses
Saml. J. Van Stavern
Jos. P. Connolly

Inventor
Robert W. Park
Connolly Bros., Attorneys

UNITED STATES PATENT OFFICE.

ROBERT W. PARK, OF PHILADELPHIA, PENNSYLVANIA.

IMPROVEMENT IN SELF-GENERATING GAS-LAMPS.

Specification forming part of Letters Patent No. **184,261**, dated November 14, 1876; application filed April 20, 1876.

To all whom it may concern:

Be it known that I, ROBT. W. PARK, of Philadelphia, in the county of Philadelphia and State of Pennsylvania, have invented certain new and useful Improvements in Self-Generating Gas-Lamps; and I do hereby declare the following to be a full, clear, and exact description of the invention, such as will enable others skilled in the art to which it pertains to make and use it, reference being had to the accompanying drawings, which form part of this specification, in which—

Figure 1 is a vertical central section of my invention. Fig. 2 is a bottom view.

The object of my invention is to provide a lamp especially adapted to the lighting of streets and large apartments, not being designed for ordinary household use, said lamp burning liquid hydrocarbons converted into a gaseous form in a retort heated by the flame of the lamp itself.

My improvements consist in the peculiar construction and combination of parts, as hereinafter more fully described, having reference particularly to novel means of connecting the fount and retort, so as to obtain the required pressure for maintaining a steady and powerful flame without locating said fount above said retort.

Referring to the accompanying drawing, A designates a close vessel of any suitable shape, preferably cylindrical, having a central open space or well, B, in which is located the retort C, said retort being also, by preference, a cylinder. *a* represents an opening in the top of the fount for supplying the same with liquid, said opening being tightly closed by a screw-stopper, *a*¹; and *a*² is an orifice, through which the oil passes through a coiled pipe, D, to the retort C. The opening *a*², it will be remarked, is in the bottom of the fount A, so as to obtain the full force of the gravity and expansive pressure of the liquid. *d* is a cock located near the opening *a*², and governing the supply of liquid to the coil D and retort C. The retort C has wings or arms *c*, which pass through the walls of the fount A and enter the liquid contained therein. Any desired number of these arms may be employed, or they may be wholly dispensed with when light oils are burned. E represents a tube, having

a blank or closed end, *e*, in which is made one small perforation or needle-hole, *e*¹, the other end of said tube being threaded and screwed into the head *e*² of the retort. The packing F, with which the retort C is filled, extends up into said tube. G represents a tube of larger diameter than the tube E, encircling and extending above the latter, resting on a shoulder, *e*², as shown. Said tube is formed with two or more openings, *g g*, and into its upper end is screwed the stem *h* of the burner H. Said stem has beveled notches *h*¹, through which are formed openings *h*², for a purpose hereinafter more fully to be described. I represents a copper chimney or cylinder, encircling the retort C, as shown, and resting on the arms *c*, when said arms are employed. When said arms are not employed, the chimney I may be extended all the way to the bottom of the retort. *i i* are openings for the admission of air to the chimney I, and K is an annular trough secured to said chimney, as shown.

The operation is substantially as follows: The fount A being supplied with oil and the stopple *a*¹ securely closed, the cock *d* is opened, permitting the passage of oil through the coil D to the retort C, whence it is carried, by capillary attraction, to the tube E. A small quantity of alcohol or turpentine previously placed in the trough K is now ignited, generating heat sufficient to volatilize the oil in the tube E, which, in a gaseous form, fills the chamber *g*¹ in the larger tube G. A portion of this gas finds an exit through the openings *g g*, the remainder passing into the stem *h*, and thence through the openings *h*² and burner H. The gas issuing through the openings *g* and *h*² is projected against the chimney I, being there ignited, and serving to heat said chimney. The chimney conducts its caloric to the retort C, serving to volatilize the oils therein, and also, when arms *c* are employed, to the fount A, the heat conveyed to the latter being sufficient to produce an expansion of its contents, and obtain the necessary pressure for forcing said contents, as required, into the retort C.

In lieu of the coil D, which, by preference, is made of copper, the better to conduct heat, a false bottom, forming a chamber beneath

the fount A and retort C, may be employed, the communication being made between the parts substantially the same as when the coil is employed—namely, by suitable pipes, with a valve or valves.

What I claim as my invention is—

1. The fount A, formed with an exit-opening, a^2 , in its bottom, in combination with the coil D, or equivalent communication, substantially as shown and described.

2. In combination with the retort C, the copper chimney or tube, for conveying heat to the said retort, substantially as shown and described.

3. The combination of retort C, tubes E and G, having openings $e^1 g$, burner-stem h , hav-

ing openings h^2 , and chimney or heat-conveyer I, the several parts being constructed and arranged for operation substantially as shown and set forth.

4. The combination of fount A, retort C, intermediate connection D, tubes E G, burner H, and chimney or heat-conductor I, substantially as described, for the purpose set forth.

In testimony that I claim the foregoing I have hereunto set my hand this 14th day of April, 1876.

ROBERT W. PARK.

Witnesses:

SAML. J. VAN STAVOREN,
CHAS. F. VAN HORN.