

A. ORME.  
STEAM STOP-VALVE.

No. 184,294.

Patented Nov. 14, 1876.

Fig. 1

Fig. 2

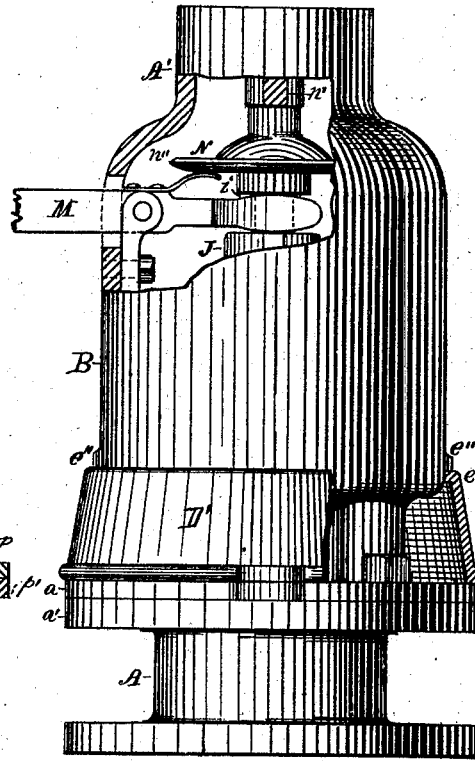
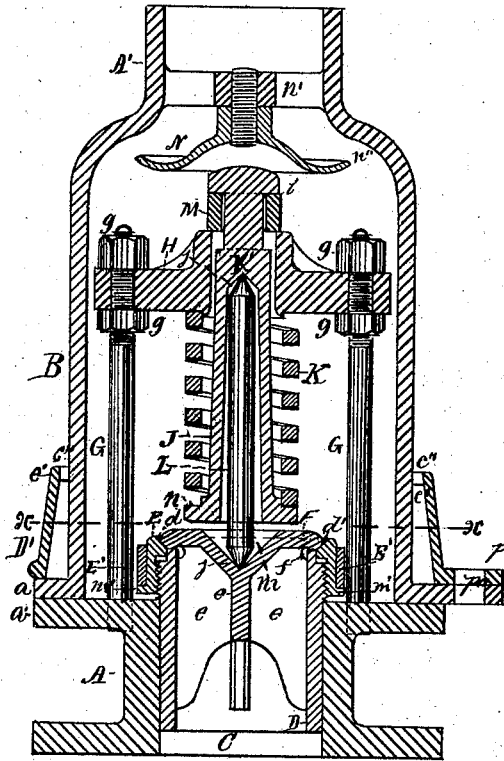

WITNESSES:  
*Julius Wilkie*  
*C. H. Sherburne,*

INVENTOR:  
*Alexander Orme,*  
*By Bradley & Sherburne*  
*his Attorneys,*

A. ORME.  
STEAM STOP-VALVE.

No. 184,294.

Patented Nov. 14, 1876.

Fig. 3

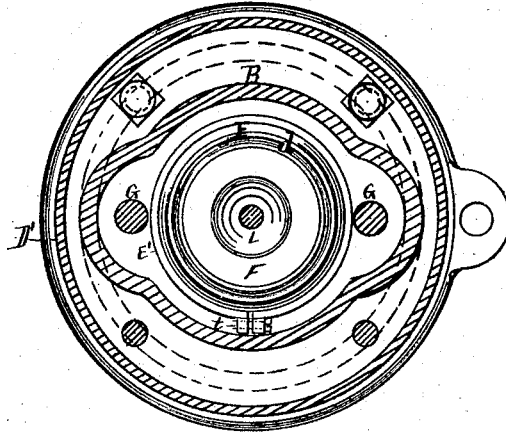

Fig. 4

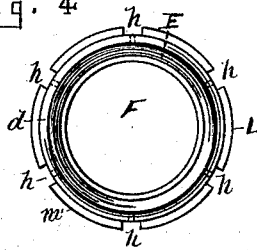
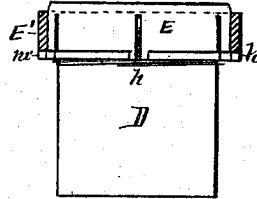

Fig. 5



WITNESSES:

*Julius Wilcke*  
*A. H. Sherburne.*

INVENTOR:

*Alexander Orme,*  
*By Gridley & Sherburne,*  
*his Attorneys.*

# UNITED STATES PATENT OFFICE.

ALEXANDER ORME, OF CHICAGO, ILLINOIS.

## IMPROVEMENT IN STEAM STOP-VALVES.

Specification forming part of Letters Patent No. 184,294, dated November 14, 1876; application filed August 17, 1876.

*To all whom it may concern:*

Be it known that I, ALEXANDER ORME, of Chicago, in the county of Cook and State of Illinois, have invented certain new and useful Improvements in Safety-Valves; and I do hereby declare the following to be a full, clear, and exact description thereof, which will enable others skilled in the art to which it appertains to make and use the same, reference being had to the accompanying drawing, forming part of this specification, in which—

Figure 1 represents a vertical central section of a safety-valve embodying my said invention. Fig. 2 represents an elevation of the same, a portion of the outer shell being broken away, showing a part of the operating parts. Fig. 3 represents a sectional plan of the same taken on the line *x x*, Fig. 1. Fig. 4 represents a top view of the valve-seat detached; and Fig. 5 represents an elevation of the same.

Like letters of reference indicate like parts.

My invention relates to that class of safety-valves used upon steam-boilers for the purpose of relieving the boiler of any excessive pressure of steam above that which it is designed to carry; and the object of my invention is to improve the safety-valve for which I obtained Letters Patent dated March 16, 1875.

My invention consists in the means employed in holding the valve upon its seat against the pressure of steam in the boiler, and in the means employed in holding the adjustable angular seat in a fixed position when adjusted, and also in the arrangement of the parts employed in locking the outer case to the base, so as to prevent the valve from being tampered with, all of which will be hereinafter more fully set forth.

In the drawing, A represents the base of the valve-case, which may be attached to the dome-plate of the boiler in any known manner. B is the case inclosing the operating parts, and which is provided at its lower end with an outward-projecting flange, *a*, fitted to rest upon a like flange, *a'*, on the base A, as shown in Fig. 1, and is firmly held thereon by screw-bolts *b* passing through the said flange *a* into the flange *a'*, as shown in Figs. 2 and 3. The base A is provided at its cen-

ter with an annular opening, C, which communicates with the interior of the boiler through a corresponding opening in the dome-plate. (Not shown.) D is annular bushing, which is tightly fitted within the opening C, and extends upward above the base, and is screw-threaded at its upper end externally, as shown in Fig. 1.

E is an annular ring fitted upon the threaded portion of the bushing D, and so arranged as to admit of being turned around on the said bushing, the object of which is to allow the ring to be raised or lowered as may be desired. The upper edge of this ring is chamfered on its inner side, forming an angular face, *d*, the latter extending downward to the end of the bushing.

F is the valve, which is provided on its lower surface with radial wings *e* adjusted to fit the bore of the bushing in the usual manner. The diameter of the upper portion of this valve exceeds the diameter of the wings forming an annular horizontal face, *f*, adjusted to bear upon the upper end of the bushing, as shown in Fig. 1, and the valve is leveled on its outer side, forming an angular face, *d'*, the plane of which is parallel with the plane of the angular face *d* on the ring. G G are vertical studs, which are permanently secured within the flange *a'* of the base, and extend upward to a point slightly above the center of the case. H is a cross-head, mounted on the upper end of the studs, and secured in a fixed position thereon by screw-nuts *g g* arranged upon the respective studs above and below the cross-head. J is a primary spindle, which passes loosely through an opening formed centrally through the cross-head, and extends downward to a point immediately over the valve, as shown in Fig. 1, and is provided at its lower end with an annular flange, *n*, formed thereon. K is a spiral spring, which is loosely fitted upon and around the primary spindle between flange *n* and the cross-head. The primary spindle is made hollow, as shown in Fig. 1, the said hollow or cavity extending upward to a point near the center of the cross-head, and converging at its upper end to one common center, as shown at K'. L is the valve-spindle, which is loosely fitted within the cavity

in the primary spindle, and is made pointed at its ends, as shown at *jj*. The upper point of the spindle is fitted into the converging point of the cavity in the primary spindle, and the lower point is fitted into a conical recess, *m*, formed centrally in the upper surface of the valve, as shown in Figure 1.

The object of loosely fitting the primary spindle within the opening in the cross-head, and of fitting the valve-spindle within the primary spindle and recess in the valve, as described, is to admit of a slight radial movement of the valve-spindle and primary spindle independent of any movement of the valve, and thereby prevent any unequal pressure of the spring upon the valve, which would otherwise be produced by any improper adjustment of the cross-head.

*M* is a horizontal lever, which is fulcrumed to a bracket on the inner surface of the case, near its upper end, and extends outward through a mortise formed therein, and is so arranged as to admit of a free-and-easy tilting movement. This lever is fork-shaped at its inner end, and passes into a groove, *i*, formed around the primary spindle near its upper end, the object of which is to provide a means of lifting the primary spindle so as to relieve the valve from the pressure of the spring, and thereby allow the valve to lift from its seat when the pressure of steam in the boiler is below the pressure at which the spring is adjusted to carry.

The diameter of the upper end of the case is less than the diameter of the lower end, forming a neck, *A'*, through which the steam escapes from the case.

*N* is an annular concaved plate, which is attached to a cross-bar, *n'*, extending centrally across the opening in the neck, as shown in Fig. 1. The area of this plate exceeds the area of the opening in the neck, and it is located below the same, so as to form an annular space, *n''*, between the periphery and the converging surface of the case, through which the steam escapes. The object of this plate is to provide a guard which will prevent any substance from being dropped into the case that would in any way prevent a complete operation of the valve.

Loosely mounted upon and around ring *E* is a supplemental ring, *E'*, adjusted to turn thereon. The supplemental ring is made of a strip of suitable metal, bent in an annular form, and bolted together at its ends, as shown in Fig. 3, forming an outward-projecting lug, *t*, arranged to bear against one of the studs *G* when the ring is turned to the proper point; or the ring may be cast in an annular shape, with the lug *t* formed thereon, if desired. The ring *E* is provided at its base with an outwardly-projecting flange, *m'*, within which is formed a series of notches, *h*, as shown in Fig. 4, which notches are each adjusted to alternately receive a depending lug, *h'*, on the lower edge of the supplemental ring *E'*, by which means the two rings are

locked together, so that neither one of them can turn independent of the other, the object of which is to lock the ring *E* in a fixed position, when properly adjusted, by so adjusting the supplemental ring thereon as to bring the lug *t* against one of the studs.

*D'* is an annular ring, loosely fitted upon and around the base of the case *B*, and arranged to rest upon the flange *a* of the same. This ring is provided at its upper edge with an inwardly-projecting flange, *e'*, arranged to fit loosely around the wall of the case, and which flange is provided with notches *e'' e''*, arranged opposite to each other, as shown in Fig. 1. The case *B* is provided on its outer surface with lugs *e'' e''*, arranged opposite each other, and of the proper size to pass loosely through the notches *e''* in the flange of the ring, and are located on the case, at the proper distance from the bottom thereof to admit the ring between them and the flange *a* of the case. The ring *D'* is also provided at its lower edge with an outwardly-projecting lug, *p*, corresponding with a like outwardly-projecting lug, *p'*, on the flange *a* of the case, which are each provided with an opening, *p''*, formed through them to receive the bolt of an ordinary padlock, by which means the ring can be locked so as to prevent it from being removed or displaced.

The arrangement of the ring *D'* is such as to wholly surround and cover the bolts uniting the case *B* to the base, and the notches in the flange are so arranged relatively to the position of the lug *p* that when adjusting the ring upon the case, and in position to admit of passing the lock-bolt through the openings *p''*, the ring must be placed in proper position on the case to allow the lugs *e'' e''* to pass through the notches in the flange. The ring is then dropped down so as to rest upon the flange *a*, when it is turned partly around to bring the openings *p''* in the same plane, thereby causing the flange on the ring to pass under the lugs, thus preventing the ring from being so elevated as to give access to the bolts connecting the case to the base without removing the lock-bolt, and thereby preventing the bolts from being unscrewed, so as to admit of removing or elevating the case, the object being to prevent the valve from being tampered with.

The spring *K* is compressed to produce a pressure on the valve per square inch equal to the desired pressure of steam which the boiler is intended to carry by lowering the cross-head *H* and tightening the nuts *g g*, so as to hold the cross-head at the requisite adjusted point. The ring *E* is so adjusted as to form a slight space between the angular face *d* and the corresponding face *d'* on the valve, and is locked in position by the supplemental ring *E'*, as previously described.

When the several parts are adjusted the operation of the valve is the same as described in my previous Letters Patent.

Having thus described my invention, what

I claim as new, and desire to secure by Letters Patent, is—

1. The combination, with the valve F, of the hollow primary spindle J, valve-spindle L, spring K, and cross-head H, substantially as and for the purpose specified.

2. The combination, with the ring E, base A, bushing D, and studs G G, of the supplemental ring E', substantially as and for the purpose specified.

3. The combination, with the case B, pro-

vided with lugs  $e'' e''$ , of the ring D', flange  $a$ , lugs  $p p'$ , and lock-bolt openings  $p''$ , substantially as and for the purpose specified.

4. The combination, with the case B, of the annular concaved guard-plate N, substantially as and for the purpose specified.

ALEXANDER ORME.

Witnesses:

N. H. SHERBURN,  
WILLIAM JONES.