

C. G. & F. G. SARGENT.  
WOOL-WASHING MACHINES.

No. 184,301.

Patented Nov. 14, 1876.

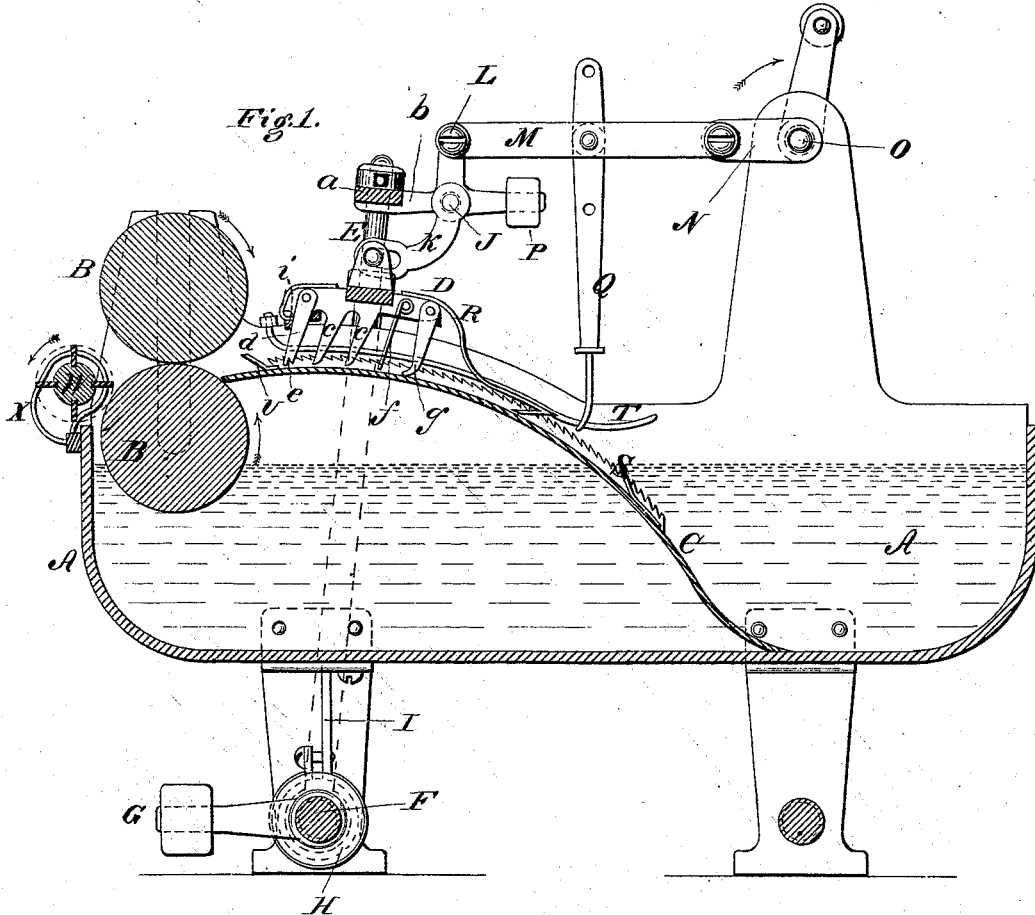

Witnesses:

David S. Twitchell,  
Will H. Dodge.

Inventor:

C. G. & F. G. Sargent  
By their attys.  
Dodge & Son.

C. G. & F. G. SARGENT.  
WOOL-WASHING MACHINES.

No. 184,301.

Patented Nov. 14, 1876.

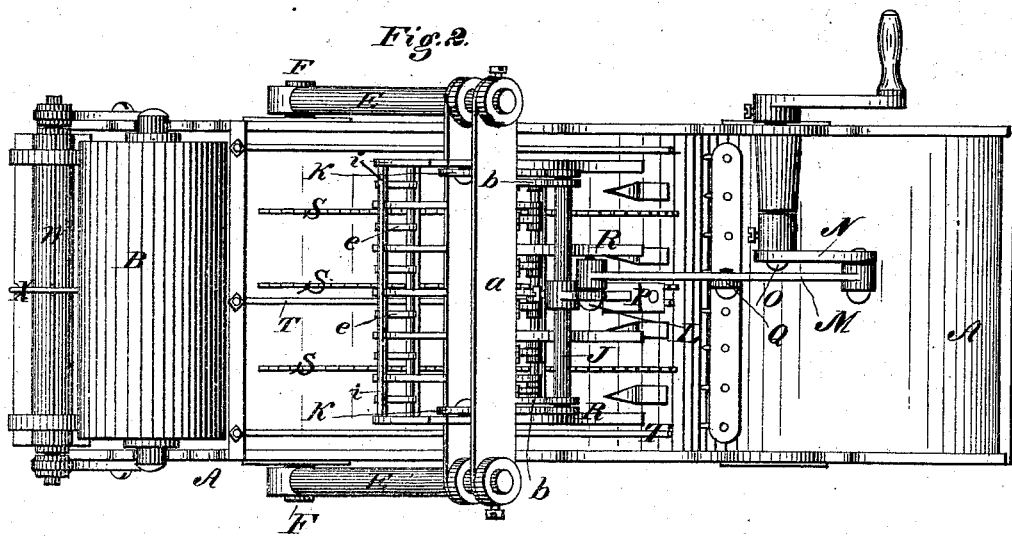

Witnesses:

Ormond S. Twitchell.  
Will H. Dodge.

Inventor:

C. G. & F. G. Sargent  
By their attys.  
Dodge & Son

# UNITED STATES PATENT OFFICE.

CHARLES G. SARGENT AND FREDERICK G. SARGENT, OF GRANITEVILLE,  
MASSACHUSETTS.

## IMPROVEMENT IN WOOL-WASHING MACHINES.

Specification forming part of Letters Patent No. **184,301**, dated November 14, 1876; application filed July 19, 1876.

*To all whom it may concern:*

Be it known that we, CHARLES G. SARGENT and FREDERICK G. SARGENT, of Graniteville, in the county of Middlesex and State of Massachusetts, have invented certain Improvements in Wool-Washing Machines, of which the following is a specification:

Our invention relates to that class of machines which consist of a bowl or tank provided with squeezing-rolls at one end, and with reciprocating devices for feeding the fiber from the bowl to the rolls; and the invention consists in a novel construction and arrangement of parts, whereby a single carrier is enabled to deliver the fiber from the bowl to the rolls without the assistance of the rakes, secondary carriers, and other devices ordinarily required; in the manner of mounting and operating the carrier, whereby it is lowered during its advance, and raised during its retreat; in providing the carrier with improved teeth of different forms, and with hooked arms at the rear end; in springs arranged to insure the fall of the pivoted carrier-teeth, and their consequent engagement with the fiber during their advance; in providing the inclined table on which the fiber is carried to the rolls with raised toothed ribs and spring-teeth, to prevent the fiber from moving backward; in mounting above and parallel with the table longitudinal spring-arms, to hold the fiber down and assist the carrier in its action; in providing the doffer-roll with guards to prevent the fiber from winding thereon; and in other details hereinafter described.

Figure 1 represents a longitudinal vertical section through the center of our machine; Fig. 2, a top-plan view of the same.

A represents the tank or bowl, constituting the body of the machine; B B, the squeezing-rolls, mounted at one end of the same; C, the curved inclined table, extending from the bottom of the bowl upward to the squeezing-rolls; and D, the reciprocating carrier, provided with depending teeth, and arranged to move back and forth over the face of the table, for the purpose of delivering the fiber over the face of the table from the bowl to the rolls.

As shown in the drawings, the carrier D has

its ends mounted and arranged to slide upon the upper ends of two upright swinging arms, E, extending down past the sides of the body, and secured at their lower ends firmly to a transverse rock-shaft, F, which latter is provided with a weighted arm, G, to counterbalance the carrier when it is drawn downward over the table. The rock-shaft F is also provided with a pulley, H, encircled by a metal friction-strap, I, which is secured at one end to the body, so that it tends to prevent the vibration of the arms E and the reciprocation of the carriage, for a purpose hereinafter explained.

The vibrating arms E are connected at the upper end by a cross-bar, a, which is provided with two rigid arms, b, supporting a rock-shaft, J, which latter is provided with two slotted arms, K, engaging with studs on the carrier, with a weighted arm, P, to counterbalance the carrier, and with an upright arm, L, which is connected by a pitman, M, with a driving-crank, N, through which the power is applied to drive the machine.

When the crank is rotated the pitman moves the carrier D back and forth over the table to and from the rolls. Owing to the fact that the friction band or brake I tends to resist any movement of the arms E, the backward strain of the pitman M causes the arm L to turn the rock-shaft J, and thereby causes the arms K to raise the carrier D from the table, so that as the carrier is drawn backward it passes freely over or above the fiber; but as the pitman is thrown forward it causes the arms to lower the carrier, so that its teeth will engage in and carry forward the fiber. Thus it will be seen the carrier is raised during its retreat and lowered during its advance with perfect certainty, so that during the advance it takes a firm hold in the fiber, and that during the retreat it has no tendency to carry the fiber backward.

While it is preferred to employ the rock-shaft and arms for raising and lowering the carrier, it is obvious that other devices for the same purpose may be substituted between the pitman and the carrier, provided the brake is retained to resist the reciprocation of the carrier.

The essential feature of the arrangement is the employment of a brake to resist the forward and backward movement of the carrier, so that the pitman may cause the action of the raising and lowering devices before the movement endwise commences. To the rear side of the carrier D there are attached a series of arms, R, extending backward over the table, and provided at their rear ends with hooks, which engage with the fiber and draw the same from the bowl upon the table, so that it is caught and carried forward by the teeth of the carrier, the fiber which is carried up by the hooks at one movement being carried forward by the carrier at the next movement.

By thus arranging the parts the machine is enabled to deliver the fiber from the bowl to the rolls with a single carrier, and without the use of the rakes, secondary carriers, and other parts ordinarily employed, so that we are enabled to produce a machine which is cheaper, more simple, and of smaller size than those of the usual construction.

For the purpose of assisting the hooked arms R in the delivery of the fiber upon the table, there may be secured to the pitman M a depending rigid bar, Q, provided with a series of teeth or fingers, as clearly shown in the drawings; but it should be distinctly understood that the use of this toothed bar or rake Q, although sometimes beneficial, is not necessary in order to render the machine operative, the construction of the carrier being such that it will deliver the fiber from the bowl to the rolls alone, and without the assistance of the rake.

For the purpose of preventing the fiber from sliding backward on the table during the backward movement of the carrier, and of enabling the teeth of the carrier to take a better hold on the fiber, the face of the table C is provided with longitudinal raised ribs S, having their upper edges provided with teeth which are beveled or inclined on the rear side, as shown. The teeth engage in the fiber, and hold the same from moving backward, but permit it to be carried freely forward toward the rolls, while the ribs themselves serve to sustain the fiber above the surface of the table, so that the ends of the carrier-teeth extend below it, and carry it cleanly and positively forward.

As an additional means of security against the backward movement of the fiber, the face of the table is provided, near the squeezing-rolls, with inclined spring-teeth U, which yield and permit the fiber to pass over them toward the rolls, but rise and oppose any movement of the fiber in the opposite direction.

For the purpose of holding the fiber down in a compact layer on the face of the table, and enabling the carrier-teeth to act thereon to a better advantage, we arrange above the face of the table a series of horizontal spring-arms, T, having their forward ends secured

to a cross-bar, i, and their rear ends curved upward and left free to rise and fall. The fiber, being carried under the ends of the arms, is held down thereby upon the table with a gentle pressure, in a close compact layer, so that it cannot escape, and that the hooked arms and the carrier-teeth take a firm hold therein. The teeth of the carrier may all be rigid or all arranged to yield and fold up as the carrier is moved backward; but it is preferred to make part of them rigid and the remainder yielding, as shown in Fig. 1, in which *c c* represent the rigid, and *d, f,* and *g* the yielding teeth. The teeth *d*, mounted in the front of the carrier, are pivoted at their upper ends, and arranged to lock against a shoulder, by which they are held in position to operate as the carrier moves forward.

In order to prevent the teeth *d* from remaining turned and riding forward over the fiber, each tooth has a notch, *e*, cut in its end, as shown, leaving a sharp shoulder, which engages in the fiber, and insures the descent of the tooth the instant that the carrier begins its forward movement. In addition to, or as a substitute for, the notches *e*, a bar, *i*, may be arranged in front of the teeth *d*, and secured at its ends to springs, which force it against the teeth, as shown, so as to urge them downward and insure their engagement with the fiber. The teeth *f*, arranged near the rear side of the carrier, are made of spring-wire, with their upper ends coiled and secured to the carriage, as shown, so that they always tend to resume their operative positions after being turned up in riding backward over the fiber. The teeth *g*, which are pivoted and sustained in the same manner as the teeth *d*, have their lower ends bent forward, as shown, to ride under the fiber and lift the same from the toothed ribs S, so as to insure a clean and entire delivery of the fiber from the table to the rolls. After passing between the squeezing-rolls B, the fiber is delivered from the machine by a doffer-roll, W, having longitudinal ribs or blades. In order to prevent the fiber from winding upon or becoming entangled with this roll, narrow guard arms or wires X are arranged to encircle the roll, as shown, so as to support the fiber and guide it from the roll.

It is obvious that in constructing the machine various details may be modified—as, for example, that the friction-brake for holding the arms E may be of any suitable construction; that the arms R, instead of being made elastic and secured rigidly to the carrier, may be pivoted or hinged thereto; and that the hooks on the ends of the arms R, instead of being rigid, may be constructed to close up as they enter the fiber, and then open as they are drawn forward.

Having thus described our invention, what we claim is—

1. In a wool-washing machine, the combination of a bowl or tank, A, press-rolls B, an inclined table, C, and a single reciprocating

carrier, D, substantially such as shown and described, constructed and arranged to deliver the fiber from the bowl to the rolls without assistance.

2. In a wool-washing machine, the combination of the table C and the reciprocating toothed carrier D, provided with hooked rear arms R, substantially as shown.

3. The combination of the swinging arms E, retarded in their movement, with the vertically-sliding carrier D, mounted thereon and connected, by devices substantially as shown and described, with the pitman M, whereby the carrier is caused to rise and fall as it moves backward and forward, as set forth.

4. The combination of the shaft F, provided with the arms E and the pulley H, encircled by the friction-strap I, the vertically-sliding carrier D, mounted on the arms E, the rock-shaft J, provided with the arms K and L, and the pitman M and crank N, arranged to operate as described.

5. In combination with the pitman M, arranged to operate as shown, the toothed bar or rake Q, secured rigidly thereto, as shown.

6. The raised toothed ribs S, constructed and arranged substantially as and for the purpose described.

7. The elastic or spring teeth U, secured up-

on the face of the table C, as shown, to prevent the backward movement of the fiber.

8. The spring-arms T, arranged above the face of the table, substantially as and for the purpose described.

9. The pivoted carrier-teeth *d*, provided with the notches *e* in their lower ends, as shown and described.

10. In combination with the pivoted teeth *d*, the bar *i*, having its ends mounted on springs, as shown, and for the purpose described.

11. In a wool-washing machine, a reciprocating carrier, D, provided with elastic wire teeth F, as described.

12. The combination of the table C, provided with the raised ribs S, and the carrier D, provided with the teeth *g*, having their ends curved forward, as shown.

13. In combination with the doffer-roll W, the guards X, constructed and arranged substantially as shown, and for the purpose described.

CHARLES G. SARGENT.  
FREDERICK G. SARGENT.

Witnesses:

ARTHUR B. PLIMPTON,  
EDWARD TROMBLY.