

J. J. STEIGER.  
EMERY WHEEL-HOLDER.

No. 184,306.

Patented Nov. 14, 1876.

Fig. 1.

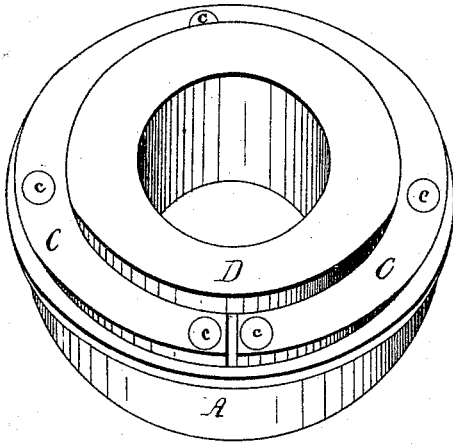

Fig. 2.

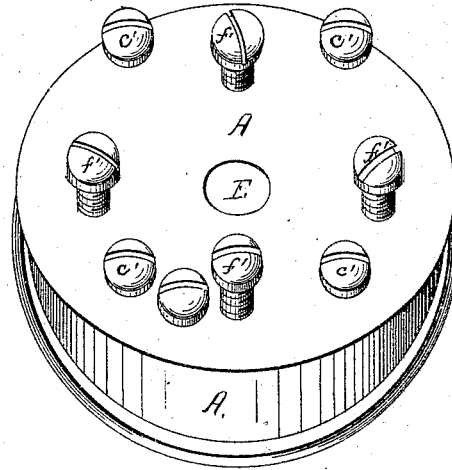

Fig. 3.

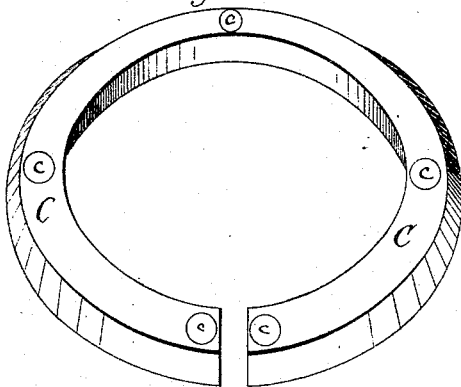

Fig. 4.

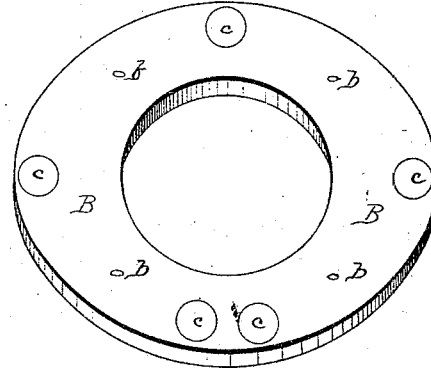
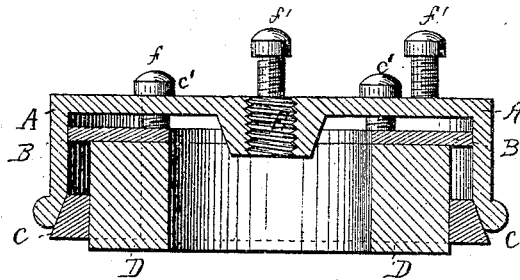

Fig. 5.



WITNESSES.

*Wm. Garner*  
*F. M. Burnham*

INVENTOR.

*J. J. Steiger*  
per  
*F. A. Schmann, atty.*

# UNITED STATES PATENT OFFICE.

JOHN J. STEIGER, OF PEORIA, ILLINOIS.

## IMPROVEMENT IN EMERY-WHEEL HOLDERS.

Specification forming part of Letters Patent No. 184,306, dated November 14, 1876; application filed June 24, 1876.

*To all whom it may concern:*

Be it known that I, JOHN J. STEIGER, of Peoria, Illinois, have invented certain new and useful Improvements in Safety Devices or Chucks for Emery-Wheels or Grindstones, for keeping emery-wheels or grindstones from bursting when revolving, and gaging them properly when worn down.

I do hereby declare that the following is a full, clear, and exact description of the same, reference being had to the accompanying drawings, and to the letters and figures of reference marked thereon, making a part of this specification.

The object of my invention is to so construct a device in such a manner as to prevent emery-wheels and grindstones from bursting when revolving, and to push the stone out, when worn off, by set-screws, so that it may be properly gaged for grinding purposes, and to hold them securely in position.

Figure 1 represents the face view of the safety device or chuck as it appears when ready for operation. Fig. 2 represents the rear view of the chuck with set-screws. Fig. 3 represents the beveled ring, which may be of one or more parts. Fig. 4 represents the follower-plate, which operates inside of the disks A, as shown by A in Figs. 1, 2, and 5. Fig. 5 represents a sectional view of chuck combined half-cut.

The follower B in Fig. 4 goes inside the disk A in Figs. 1, 2, and 5. The disk A on inside is beveled. The emery-wheel or grindstone, as shown by D in Fig. 1, is then put in the disk A. Around the emery-wheel or grindstone the beveled ring C in Fig. 3 is placed, and made to fit the beveled disk A. The set-screws in Figs. 2 and 5 marked *f'* may have shoulders or not, and after passing through the disk A their ends strike against the follower B, as in Fig. 4, and when screwed up, after the set-screws *c'* are loosened, push the

emery-wheel or grindstone out for gaging purposes. Then the set-screws *c'* are tightened by screwing them up, which brings the beveled ring C in Fig. 3 to fit into the beveled disk A, contracting it so that it fits tightly and closely around the emery-wheel or grindstone, and holds it securely in its position. The set-screws *b'* in Fig. 2 can be made with a shoulder at their ends, so that their ends may pass just through the follower at *b* in Fig. 4; or their ends may strike against the follower B without passing through the follower B at all. The set-screws *c'* pass through the holes indicated by *c* in Fig. 4, and into the threaded holes *c* in Fig. 3. A in Fig. 5 is the disk, sectional view half-cut. B in Fig. 5 represents half-cut sectional view of the follower. C in Fig. 5 represents half-cut sectional view of beveled ring. D represents emery-wheel or grindstone half-cut sectional view, all combined for uses and purposes set forth. C in Fig. 1 represents beveled ring to fit in disk A inside beveled, for uses and purposes set forth. *c* in Fig. 1 represents threaded holes for set-screws *c'*, for uses and purposes set forth. E in Fig. 2 represents hole for axle of the device or chuck. The beveled ring C in Fig. 3 may be made of one or more parts.

Having described my invention, what I claim as my invention is the following:

1. A hollow disk, A, having its inner edge beveled away, in combination with the ring C and adjusting-screws or other similar devices *c'*, the ring C being made in one or more parts, and adapted to fit the bevel of the disk A, substantially as shown.

2. The combination of the follower B and suitable adjusting devices *f'*, for regulating the emery-wheel, substantially as described.

JOHN J. STEIGER.

Witnesses:

L. O. WILSON,  
L. H. MORRIS.