

B. M. WHITING.
SASH-BALANCES.

No. 184,312.

Patented Nov. 14, 1876.

Fig-1.

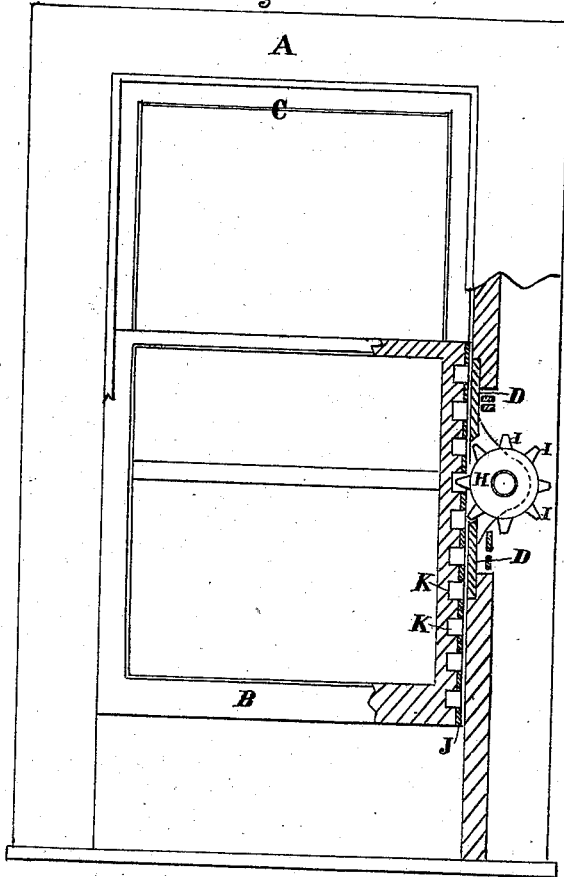

Fig-2.

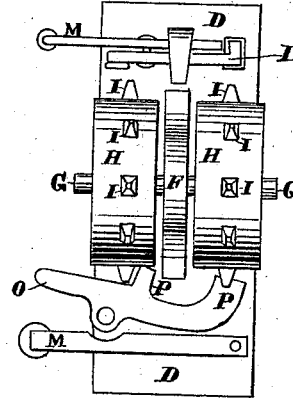
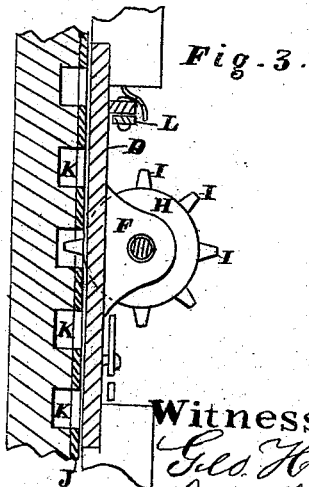
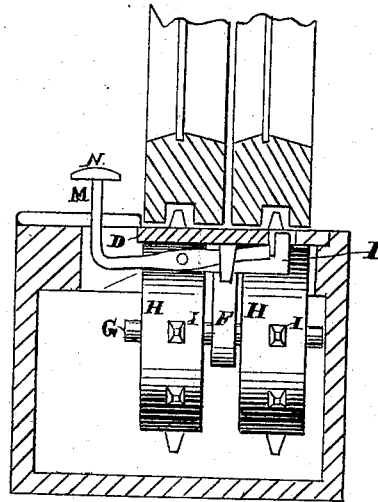

Fig-4.



Witnesses

Geo. H. Strong
Jno. L. Dorne

Inventor

Barnet W. Whiting
Dewey &
Atty.

UNITED STATES PATENT OFFICE.

BARNET M. WHITING, OF LOS ANGELES, CALIFORNIA.

IMPROVEMENT IN SASH-BALANCES.

Specification forming part of Letters Patent No. 184,312, dated November 14, 1876; application filed September 28, 1876.

To all whom it may concern:

Be it known that I, BARNET M. WHITING, of the city and county of Los Angeles, and State of California, have invented an Improved Window-Sash Balance, Stop, and Lock; and I do hereby declare the following to be a full, clear, and exact description thereof, reference being had to the accompanying drawings.

My invention relates to an improved arrangement for balancing, supporting, and locking window-sashes; and consists in certain details of construction, as hereinafter more fully described and claimed, reference being had to the accompanying drawings, in which—

Figure 1 is a window-sash with my device applied. Fig. 2 is an end view of my device. Fig. 3 is a section of the same. Fig. 4 is a horizontal section.

Let A represent a window-frame. B is the lower and C is the upper window-sash. On one side of the frame A, opposite the point where the upper rail of the lower sash and the lower rail of the upper sash come together when the sashes are in their proper positions, I make a hole in the casing of the window-frame, and over this hole I secure a plate, D, to which the main part of the operating mechanism is attached, so that the mechanism will be inside of the casing and out of sight. This plate D has a bracket or standard, F, projecting from its middle into the hollow casing, and a short arm or fixed journal, G, is secured to the extremity of this arm on each side, and at right angles to the standard. On each of these short arms or journals I mount a small hollow wheel or drum, H, so that it will revolve freely, and inside of each drum I place a coiled spring, one end of which is attached to the journal, while its opposite end is attached to the rim of the drum. Teeth or projections I I are formed on the rim of each wheel or drum, and the plate D is slotted opposite the teeth, so that they will project through, as represented. On the edge of each sash I secure a metal plate, J, in which I make notches or recesses K K at short distances apart, corresponding with the cogs of the wheels H, so that they will form racks, with

which the teeth or cogs of the drums will engage in order to raise, lower, or fasten the sashes. The cogs of one wheel engage with the lower sash, while the cogs of the other engage with the upper sash, and before placing the sash in position the wheels are turned, so as to create a tension on the springs, so that they will balance the weight of the sashes. A pawl or dog, L, is attached to the inside of the plate D opposite each sash, so as to project through a hole in the plate and enter the notches of the rack-plate J as they come opposite it. Each of the pawls is operated by a lever, M, which projects through the casing in front of the sashes, and the end of which is formed into a button or head, N, so that by pressing inward on the button the dog or pawl will be lifted free from the notches in the rack-plate, and thus allow the sashes to move up or down. These dogs or pawls fasten the window at any desired point, one of them being arranged opposite the upper and the other opposite the lower sash. O is a pivoted lever, which has two arms, P P. This lever is pivoted to the plate D below the wheels or drums H, so that its arms are directly below the cogs of the drums. The end of this lever projects through a curved slot in the casing in front of the lower sash, so that by pressing downward upon the projecting end the opposite end will be raised, so as to interlock the ends of the arms P P with the cogs of the drums, and thus prevent the drums from rotating. This operation permanently locks the sash at whatever position it stands when the lever-arms are moved to interlock with the cogs.

I thus combine a sash-balance, sash-fastener, and sash-lock in a simple device, which can be readily operated and cheaply applied. The entire device, except the buttons and the end of the locking-lever, is concealed inside of the casing, so that it will present a neat appearance. The sashes can be removed in the ordinary way without trouble and replaced again when desired.

Having thus described my invention, what I claim, and desire to secure by Letters Patent, is—

1. In combination with the spring drums or

wheels H, with their cogs or teeth I arranged to engage with the rack-plate J on the edge of the sash-frame, the dog or pawl L, operated by the lever M, substantially as and for the purpose described.

2. The pivoted locking-lever O passing behind the pins I, with its arms P P, in combination with the spring drums or wheels H, having teeth or cogs I I, which engage with the

notches in the rack-plate on the window-sash, substantially as and for the purpose described.

In witness whereof I have hereunto set my hand and seal.

BARNET MATTHIAS WHITING. [L. S.]

Witnesses:

ROBT. S. MOORE,
C. F. HARPER.