

H. F. EBERTS.
HEATING CHILL-MOLDS.

No. 184,356.

Patented Nov. 14, 1876.

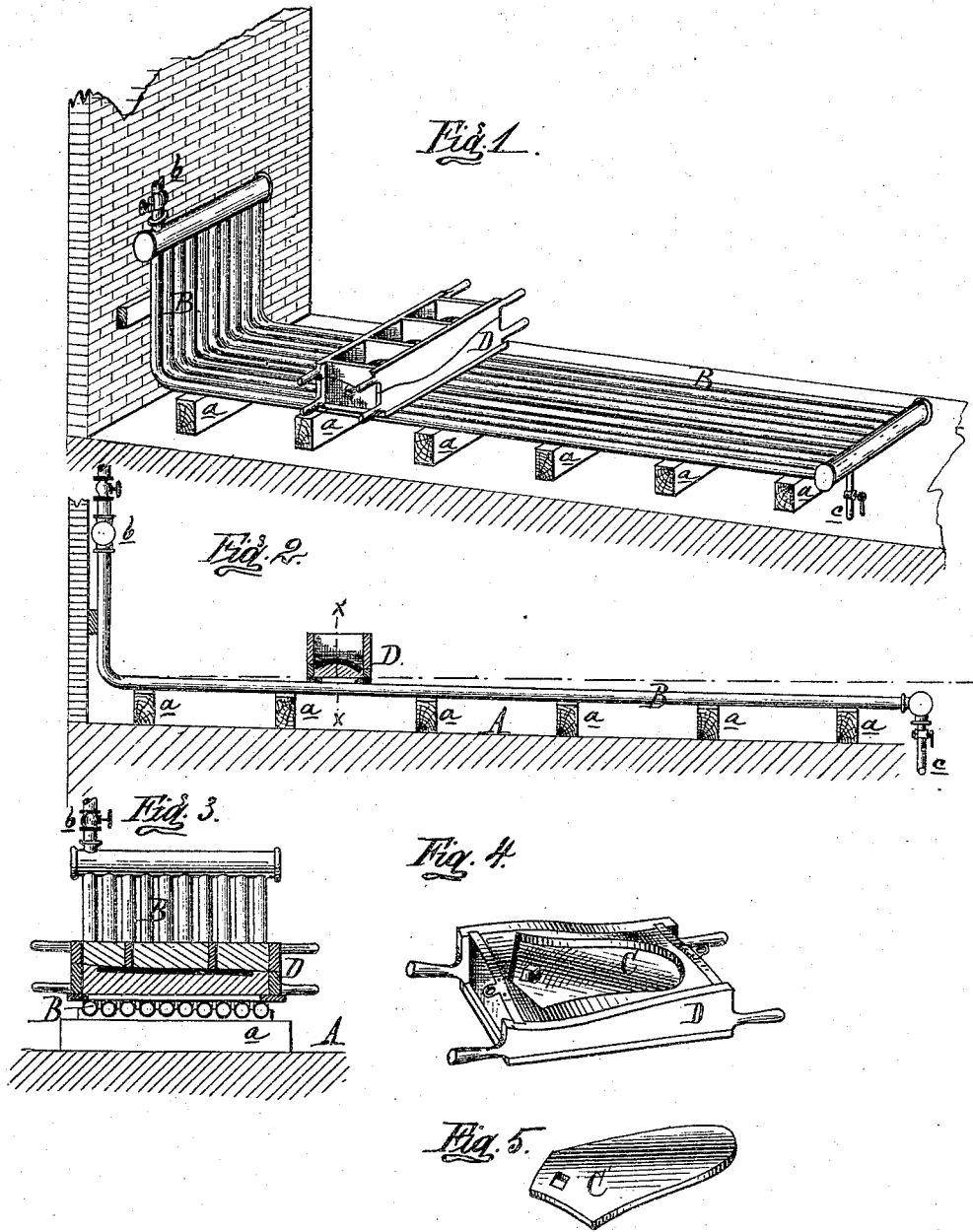

Attest:
Edward Barthell,
Charles J. Hunt.

Inventor:
H. F. Eberts
By Atty
J. S. Sprague.

UNITED STATES PATENT OFFICE.

HERMAN F. EBERTS, OF DETROIT, ASSIGNOR TO THE GALE MANUFACTURING COMPANY, OF ALBION, MICHIGAN.

IMPROVEMENT IN HEATING CHILL-MOLDS.

Specification forming part of Letters Patent No. 184,356, dated November 14, 1876; application filed September 11, 1876.

To all whom it may concern:

Be it known that I, HERMAN FREDERICK EBERTS, of Detroit, in the county of Wayne and State of Michigan, have invented an Improvement in Heating Chill-Molds, of which the following is a specification:

In casting iron in metal chill-molds great trouble has been found from rough and imperfect castings, especially in casting thin articles of large area, such as plow mold-boards, where a smooth surface on the chilled face is indispensable. Where, as in this case, the chill forms one side of the mold, moisture, naturally present in the sand of the mold, is deposited upon or collects upon the face of the chill, where, if permitted to remain long enough, it rusts the surface of the chill, and a rough surface will result in casting molten metal against it. A thin film of moisture, when the molten metal comes in contact with it, is instantly expanded in volume, and prevents the fluid metal from lying against the face of the chill, and a pitted casting will be the result.

To remedy this difficulty, pan and box chills have been used—the former partly filled with hot water and the latter with steam—to heat them and drive off the moisture from the face of the chill by evaporation. Heated chills have also been arranged to be placed in the flask just before pouring the mold; but all of these systems have inherent defects well known to practical foundrymen, and not necessary here to recapitulate.

The object I have in view is to provide an easy and expeditious means for heating any number of pan-chills after their respective flasks have been molded up, in order to insure clean and perfect chill-castings therefrom. To this end it consists in arranging a flat steam-coil just above the general level of the sand-floor of a foundry, to serve as a platform, upon which the drags of any number of flasks are supported, each drag having a pan-chill secured in its frame, and open below, so that, after the flask is molded up, steam may be blown through the pipes of the coil, from which the radiant heat naturally

arises and strikes the under sides or backs of the chills, thereby heating them to such a temperature as will drive off all moisture from their faces.

Figure 1 is a perspective view of my heating-coil with a flask in place thereon. Fig. 2 is a side elevation of the same, showing the flask in cross-section. Fig. 3 is a cross-section at *x x*. Fig. 4 is a perspective view of a pan-chill fitted in the open drag-frame of a flask, adapted to chill a plow mold-board. (Seen in Fig. 5.)

In the drawing, A represents the sand-floor of the foundry, in which are bedded two parallel wooden stringers, (not seen,) upon which cross-ties *a* are secured. These ties or saddles *a* may be placed about three feet apart to support a flat coil of steam-pipes, B, at about eight inches height above the level or surface of the floor. The coil-pipes are bent to a right angle at the upper end next the wall of the foundry, to permit them to expand and contract independently, and are supplied with steam through a pipe, *b*, tapped into their head manifold, while a drip-pipe, *c*, tapped into the foot manifold, carries off under ground the water of condensation.

The coil is inclined to carry off the drips either by sloping up the sand-floor before bedding in the stringers, (in which case the saddles *a* may be of uniform height,) or by leveling the sand-floor and using saddles of gradually-increasing height toward the head of the coil. The inclination of the coil is shown by the broken horizontal line in Fig. 2.

The pan-chill C is secured in the drag of the flask D, and the bottom of the latter is left open to allow the heat to strike the under surface of the chill when the flask is on the coil and steam is circulating through the latter.

In practice the flasks are never removed from the coils, but are molded up thereon from sand-heaps lying between pairs of coils, and after the heat is taken off the sand that has fallen between the pipes and under the coil is raked out onto the floor again.

If the molds are gated to be poured on the

side, they are left in the position shown while the chill is being heated, when, just before pouring, steam may be shut off and the flasks be turned up on their sides.

What I claim as my invention is—

1. A flat coil of steam-pipes arranged above the sand-floor of a foundry, and adapted to support a series of flasks, and to heat the chill contained in the drag-frame of each flask, substantially as described.

2. The flat coil of steam-pipes B, supported at an inclination above the sand-floor *b*, and drip-pipe *c*, for the purpose of supporting a series of flasks, and heating the chill contained in the drag-frame of each flask, substantially as described and shown.

HERMAN FREDERICK EBERTS.

Witnesses:

CHAS. J. HUNT,
H. S. SPRAGUE.