

# UNITED STATES PATENT OFFICE.

HOLLAND B. EVANS AND WILSON KESTLER, OF ST. CHARLES, MISSOURI.

## IMPROVEMENT IN SAD-IRONS.

Specification forming part of Letters Patent No. 184,360, dated November 14, 1876; application filed August 17, 1876.

*To all whom it may concern:*

Be it known that we, HOLLAND B. EVANS and WILSON KESTLER, of St. Charles, in the county of St. Charles and State of Missouri, have invented a new and useful Improvement in Sad-Irons; and we do hereby declare the following to be a full, clear, and exact description of the same, reference being had to the accompanying drawing, forming part of this specification, in which—

Figure 1 represents a vertical longitudinal section of the invention through the line *x x* of Fig. 4. Fig. 2 is a vertical transverse section of same through the line *y y* of Fig. 4. Fig. 3 is a plan view of the heater. Fig. 4 is a plan view of the sad-iron entire.

Our invention relates to that class of sad-irons which are made hollow, and designed to be heated by means of a charcoal or other fire; and it consists in constructing the hollow iron with a ventilator in its top, and with an interior plate for throwing the heat in a downward direction, also in certain other details of construction, to be hereinafter more fully described, and then pointed out in the claim.

In the accompanying drawings, the letter A denotes a sad-iron of the usual form, made hollow, and provided at its front or toe end with a tube or chimney, B, communicating with the interior of the iron for carrying off the smoke and heat. On the top of the iron are formed lugs or ears *a*, for attaching the iron to an ironing-machine, or it may be provided with a handle of any suitable construction for using the iron by hand. Immediately in rear of the chimney-opening there is arranged a plate or partition, C, which extends to near the bottom of the iron, the object of said plate being to prevent the heat and smoke from entering the chimney without having properly heated the bottom, as in the case of the ordinary sad-irons, where the top is unnecessarily heated. The iron is heated by means of a charcoal or other fire built in a case or drawer, D, which is inserted into the iron, and fills up the space between the partition and rear end of the iron. The fire drawer or box has inverted U-shaped or hol-

low bars or ribs *g* on its bottom, which are provided with side openings *b*, for admitting air into the fire-chamber, the air passing in through openings *c* in the bottom of the fire-box. Ribs *d* are formed on the bottom of the iron for supporting the fire-box above said bottom to permit the air to circulate. The necessary air for aiding the combustion of the fuel passes in at the top of the iron through an opening, E, closed by a slide, F, this being in contradistinction to admitting external air at the sides or front of the iron, which secures the blowing out of ashes from the fire chamber or box.

The fire-box is provided with a detachable sliding top plate, F, which is cut away at its front end, or provided with an opening, *f*, thereat, so that the air passing in through the opening E will enter the fire-chamber and pass through openings G at the rear end of the same. The rear or heel end of the iron being closed by an imperforate plate or door, H, it follows that the air, after having circulated through the fire, must pass under the fire-box, for thoroughly heating the bottom of the iron before it passes into the chimney. A portion of the cold air, passing through the top opening or ventilator, will circulate between the top of the iron and the top of the fire-box, so as to keep the top of the iron comparatively cool. The openings in the bottom of the fire-box and the perforated hollow ribs on the inside of the same will serve to admit air at the bottom of the fuel-bed.

Having thus described our invention, what we claim as new, and desire to secure by Letters Patent, is—

The combination of the fire box or drawer D, having a detachable top plate, F, and openings G, with the hollow sad-iron A, provided with the top opening E, a closed rear door, H, a front partition, C, and chimney B, as and for the purpose set forth.

HOLLAND B. EVANS.  
WILSON KESTLER.

Witnesses:

JOHN A. EVANS,  
A. H. EDWARDS.

J. FERGUSON.

HEATING AND FEEDING AIR TO FURNACES.

No. 184,361x

Patented Nov. 14, 1876.

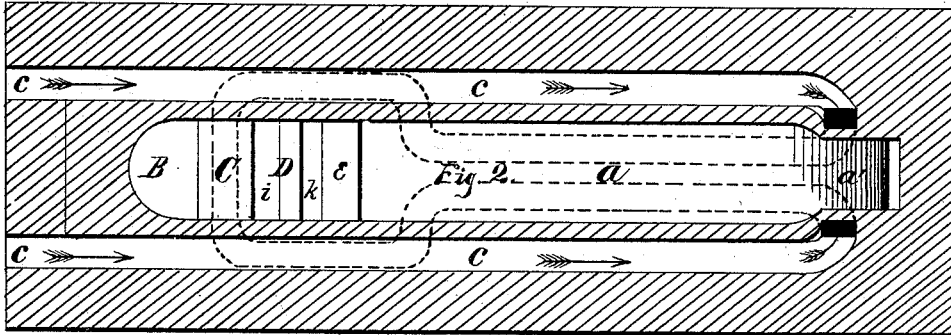
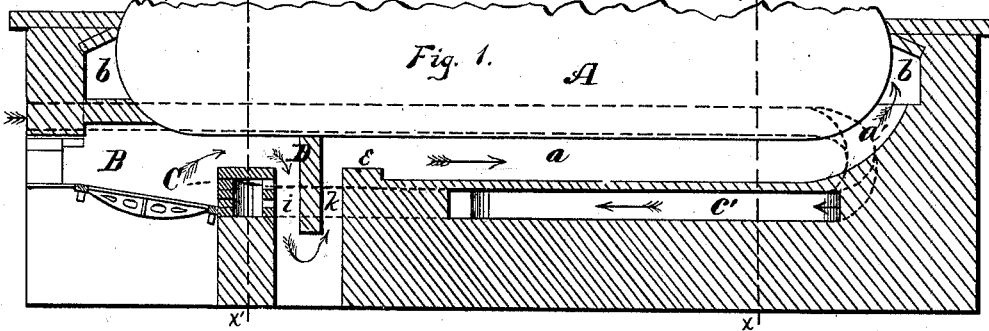
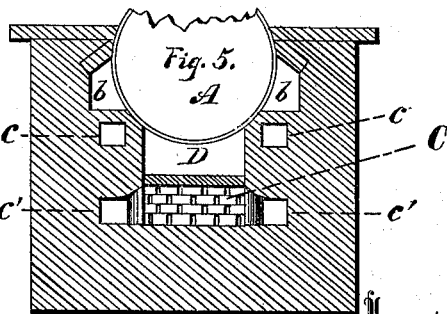
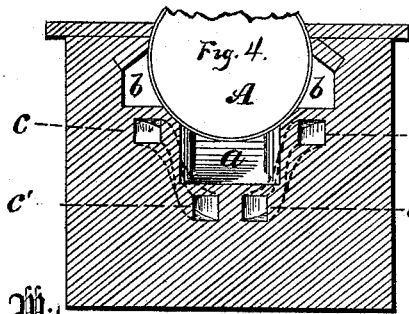
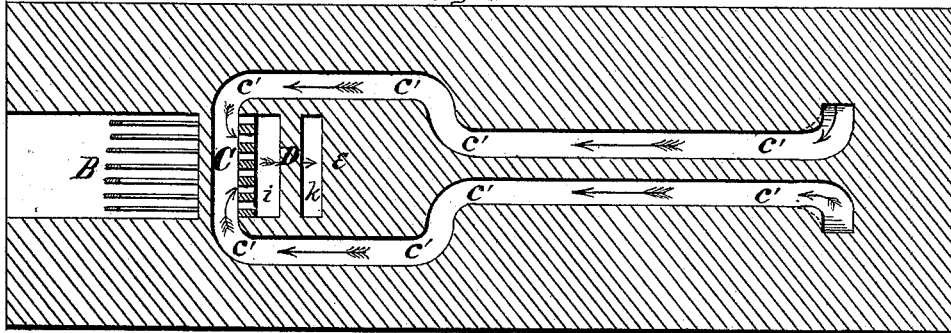

Fig. 3.



Witnesses

J. A. Pollock  
G. Smith

John Ferguson

Inventor

Connally Bros & Co

Attorneys