

J. GALT.  
LOOMS.

No. 184,364

Patented Nov. 14, 1876.

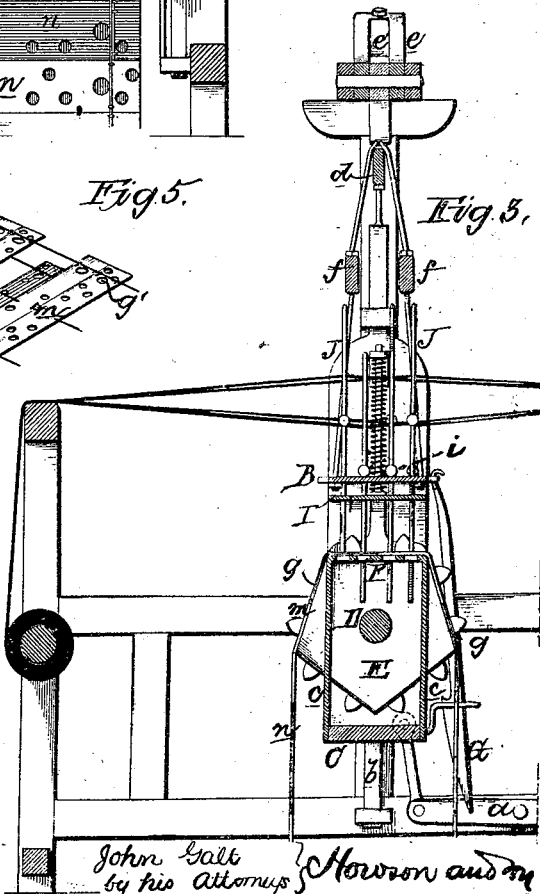
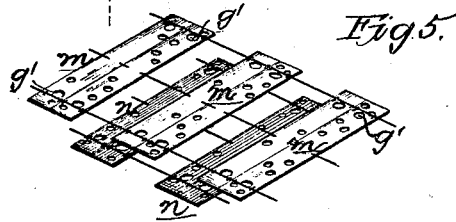
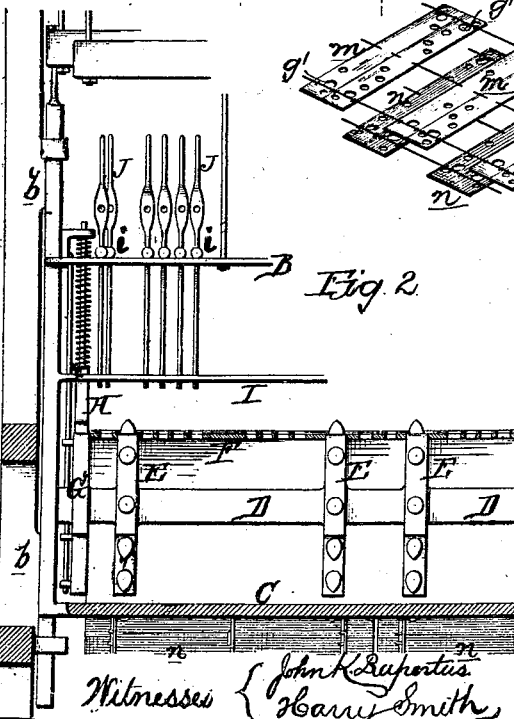
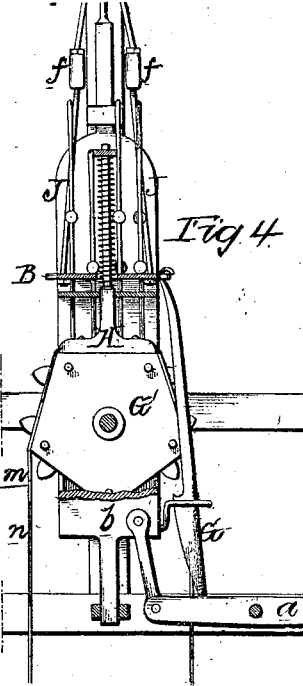
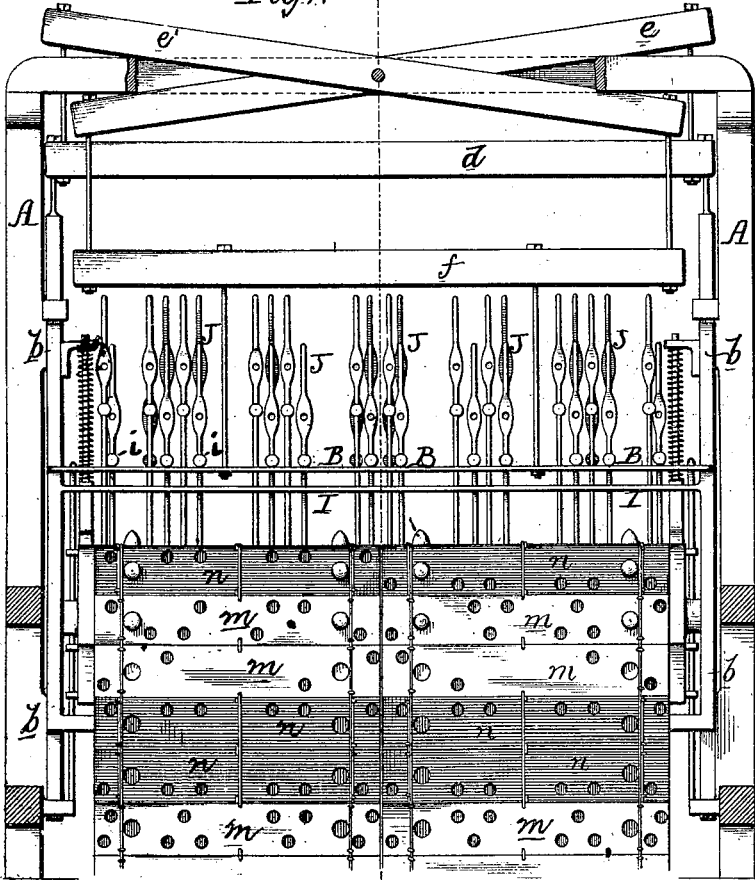

Witnesses { John K. Roberts  
Harry Smith

John Galt  
by his Attorneys } Howson and Co

# UNITED STATES PATENT OFFICE.

JOHN GALT, OF PHILADELPHIA, PENNSYLVANIA.

## IMPROVEMENT IN LOOMS.

Specification forming part of Letters Patent No. **184,364**, dated November 14, 1876; application filed March 23, 1876.

*To all whom it may concern:*

Be it known that I, JOHN GALT, of Philadelphia, Pennsylvania, have invented certain Improvements in Looms, of which the following is a specification:

My invention relates to certain improvements in what is known as the "Calderhead loom," in which the cards operate directly upon needles carrying the warp-threads without the use of the usual knot-cords, harness, nails, and leads; and the objects of my improvement are, first, to adapt the loom to the production of fabrics of any desired width without much expense; second, to facilitate the general operation of the loom. These objects I attain in the manner which I will now proceed to describe, reference being had to the accompanying drawing, in which—

Figure 1 is a transverse vertical section of my improved loom with the operating parts in an elevated position; Fig. 2, a sectional view of a portion of the same with the parts in a depressed position; Fig. 3, a longitudinal section of part of the loom on the line 1 2, Fig. 1; Fig. 4, an end view, partly in section; and Fig. 5, a perspective view of a number of the cards.

It may be well to state in the outset that the Calderhead loom above mentioned possesses several well-known advantages over the ordinary loom, among which may be mentioned its simplicity and economy of construction, and the direct action of the operating parts.

The principal objections to the Calderhead loom, as heretofore constructed, were the expense and inconvenience of the large cards considered necessary in weaving fabrics of considerable width, and the difficulty of obtaining access to the threads when operated by rigid needles guided at top and bottom. These objections I overcome in the following manner:

In the drawing, A represents part of the frame-work of a loom, near the base of which is a treadle, *a*, connected to two guided standards, *b b*, one at each side of the loom, so that, as the treadle is vibrated, a vertically-reciprocating motion will be imparted to these standards, which are connected at the top to a transverse bar, *d*, one end of the latter being attached to one end of a lever, *e*, and the other end to one end of a lever, *e'*. The lever *e* is

forked for the reception of the lever *e'*, and both levers are pivoted to the top frame of the loom. Owing to the use of the bar *d* between the standards *b* and levers *e e'*, the lateral strain caused by the movement of the ends of the levers in arcs of circles is removed from the upper ends of said standards *b*, and the easy movement of the same in their guides is insured. The opposite ends of the levers *e e'* are connected to transverse bars *f*, and from the latter is suspended a diagonally-perforated plate, B, to which a rising and falling motion is thus imparted. Secured to the standards *b b* near their lower ends is a transverse bar, C, to the sides of which are attached perpendicular plates *c*, supporting at the top transverse metallic plates F, which are perforated in the same manner as the suspension-board B. To bearings in the standards *b b* are adapted the opposite ends of a shaft, D, which extends across the loom below the plates F, and which carries a series of wheels, E, each having as many sides as the nature of the fabric to be woven may require, the edges of which project between the plates F and their supports. The edges of the wheels E are provided with pegs or nipples *g*, which are adapted to holes *g'* in the cards, so that as the wheels are turned the cards will be brought in succession over the tops of the plates F, which support the said cards.

The turning of the shaft D and its wheels is effected by the action of a hooked bar, G, hung to the suspension-board B upon pins projecting from heads G' at both ends of the shaft D, the rotation being caused partly by the downward movement of the heads G' and partly by the upward movement of the board B and its hooked arms, thus economizing the extent of vertical movement of the shaft D. The heads G have as many sides or faces as the wheels E, so that the proper leveling of said wheels may always be insured by the action upon the heads G' of the usual T-headed spring-bars H.

J J are the vertical thread-carrying needles, each perforated for the passage of the thread, and provided with a ring or bead, *i*, which rests upon the suspension-board B, and prevents the descent of the needles below a given point. In forming the shed the needles, which

must be elevated, are raised by the cards, and the others are allowed to fall by their own weight, their lower ends entering the perforations in the cards as the latter are raised. The needles are guided and steadied at their lower ends by a guide-board, I, perforated in the same manner as the suspension-board B and plates F, and connected at its opposite ends to the standards *b*.

In the present instance I have shown four sets or rows of needles, J, and in operating these needles I use two sets of cards, *m* and *n*, each set being laced together, so as to form an endless chain, which is carried round by the wheels E, the two sets being so arranged on the said wheels that the cards *m* and *n* alternate. The cards *m* are punched, so as to operate the proper needles and threads for forming the figure on the fabric, while the cards *n* are punched, so as to operate the needles and threads to produce the groundwork or body of the fabric. Each card is made in halves laced together, and, in working the loom to produce an ingrain fabric, the cards are so operated that the card-supporting plates F are occupied by one-half of a card, *m*, and one-half of a card, *n*, at the same time, the relations of the two on said plates F being changed with each movement of the wheels E, so as to insure the alternate working of the needles for both the groundwork and figure.

Thus, as will be seen on reference to Fig. 3, the two sets of needles nearest the front of the loom are being operated by the rear half of a card, *m*, and, consequently, their threads are so operated as to aid in the formation of the figure, while the two rows of needles at the rear are operated by the first half of a card, *n*, and their threads thus aid in the formation of the body. When the shaft D is turned these relations will be changed, the front rows of needles being operated by a card, *n*, to form the groundwork, and the rear rows by a card, *m*, to form the figure.

In producing a damask fabric, however, this mode of operating the cards is changed, all the needles being operated first by the cards *m*, and then by the cards *n*. Owing to the use of the supporting-plates F and disks E, the cards may be composed of a number of small pieces, thus obviating the objection arising from the great cost and inconvenience of cards large enough to operate all the needles.

It will be evident that the plates F may be made all in one piece, and have slots cut in them for the passage of the wheels.

I claim as my invention—

1. The combination of the vertical thread-carrying needles J with the transverse perforated plates F, the shaft D, and wheels E.
2. The combination of the two sets of cards *m* and *n*, arranged alternately, one set being adapted to operate the needles carrying the ground threads, and the other set the needles carrying the figuring threads, the cards being laced together, substantially as described.
3. The combination of the wheels E with the compound cards *m* and *n*, laced together and arranged alternately, each card being composed of halves, whereby each face of the wheel E is successively occupied by one-half of each card at the same time, as shown and set forth.
4. The combination of the pivoted bars *e* and *e'* and standards *b b*, with the transverse bar *d*, as set forth.
5. The combination of the heads G' and their pins with the hooked bars G and the reciprocating suspension-board B, as described.

In testimony whereof I have signed my name to this specification in the presence of two subscribing witnesses.

JOHN GALT.

Witnesses:

HARRY HOWSON, Jr.,  
HARRY SMITH.