

T. KELSEY.
COAL-CHUTES.

No. 184,387.

Patented Nov. 14, 1876.

Fig: 1.

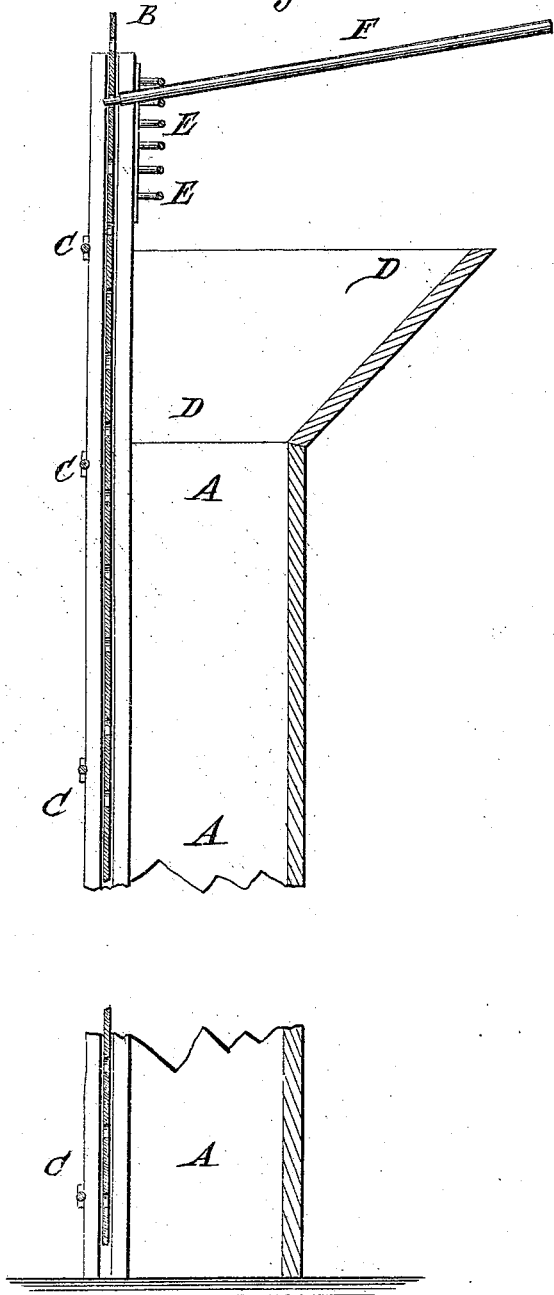

Fig: 2.

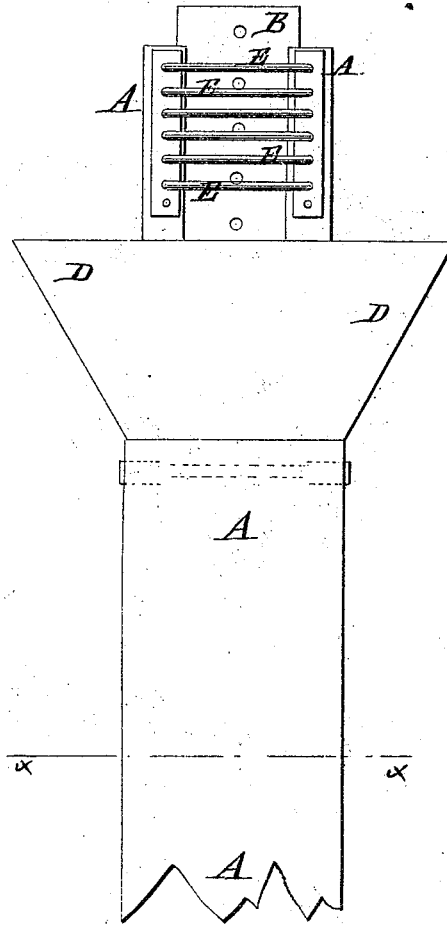
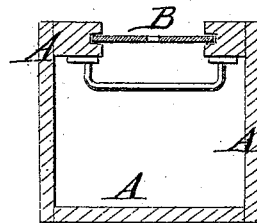

Fig: 3.



WITNESSES:

C. W. Nida
John Goethals

INVENTOR:

T. Kelsey
BY *Munnell*
ATTORNEYS.

UNITED STATES PATENT OFFICE.

THERON KELSEY, OF SOUTH BROOKLYN, NEW YORK, ASSIGNOR TO HIMSELF AND JAMES E. KELSEY, OF SAME PLACE.

IMPROVEMENT IN COAL-CHUTES.

Specification forming part of Letters Patent No. 184,387, dated November 14, 1876; application filed September 22, 1876.

To all whom it may concern:

Be it known that I, THERON KELSEY, of South Brooklyn, in the county of Kings and State of New York, have invented a new and useful Improvement in Coal-Chutes, of which the following is a specification:

Figure 1 is a vertical section of my improved device. Fig. 2 is a rear view of the same. Fig. 3 is a cross-section of the same, taken through the line *xx*, Fig. 1.

Similar letters of reference indicate corresponding parts.

The object of this invention is to furnish an improved apparatus for dropping coal and other material from a height to a floor or pile below, which shall be so constructed as to prevent the coal or other material from being broken by collision, and thus prevent the formation of fine coal or dust, and the consequent waste and loss.

The invention consists in the chute made with an open side, closed with a slide, and strengthened by cross-bars, and provided with the hopper; and the combination of the rest or fulcrum bars and the lever with the open side of the chute, and the slide provided with a longitudinal row of holes, as hereinafter fully described, to adapt it for use for dropping coal or other material from a height, as set forth.

A represents a chute, which may be square, round, or of any other desired shape, and of any desired height. Sixteen inches in diameter would be a suitable size for an ordinary chute. In the forward side of the chute A is formed a longitudinal opening of such a size as to allow the coal to pass out freely. This opening is closed by a slide, B, which works in grooves or rabbets in the chute A, at the sides of said opening, and may be kept in place by iron pins or other guides.

The open side of the chute A is strengthened, and the said chute is kept from being spread apart by the pressure of the coal, by cross or stay bars C, attached to it. To the upper end of the chute A is attached a hopper, D, of such a size as to enable the cars to be readily dumped into it. A convenient size for the hopper D would be six feet high and

six by eight feet at its top. The front side of the chute A projects above the hopper D, and to its inner or rear side are attached a number of cross-bars, E, to serve as rests or fulcrums for the lever F, for raising the slide B. In the slide B is formed a longitudinal row of holes to receive the end of the lever F, as shown in Fig. 1.

The slide B may be raised by a tackle or other device, if desired. The lower end of the chute A rests upon, and is secured to, the floor of the shed, yard, or vessel, and its upper part is supported in position by the framework of said shed or yard. In using the device the chute A is first filled to, nearly to, or a little above the platform of the hopper D, and should be kept filled to that point. Then, as the coal is dumped into the hopper D, it is allowed to flow out of the open side of the chute A by raising the slide B. The coal may be allowed to flow out continuously or intermittently, as may be desired.

This construction enables the outflow of the coal to be checked at any time, and to be readily controlled to keep the chute filled to the proper point. This construction also guards against all the coal running out of the chute should a slide occur in the pile below. By this construction the breakage of the coal and the formation of fine coal or coal-dust will be prevented.

Having thus described my invention, I claim as new and desire to secure by Letters Patent—

1. A coal-chute provided with a side opening, extended from bottom to hopper, or nearly to hopper, in combination with a slide, B, that is gradually raised as the coal accumulates in the bin, so that there may be no sudden fall of coal to bin from the hopper.

2. The combination of the rest or fulcrum bars E and the lever F with the open side of the chute A and the slide B, provided with a longitudinal row of holes, substantially as herein shown and described.

THERON KELSEY.

Witnesses:

JAMES T. GRAHAM,
C. SEDGWICK.