

W. T. KEMPLE.
CONSTRUCTION OF WELLS.

No. 184,388.

Patented Nov. 14, 1876.

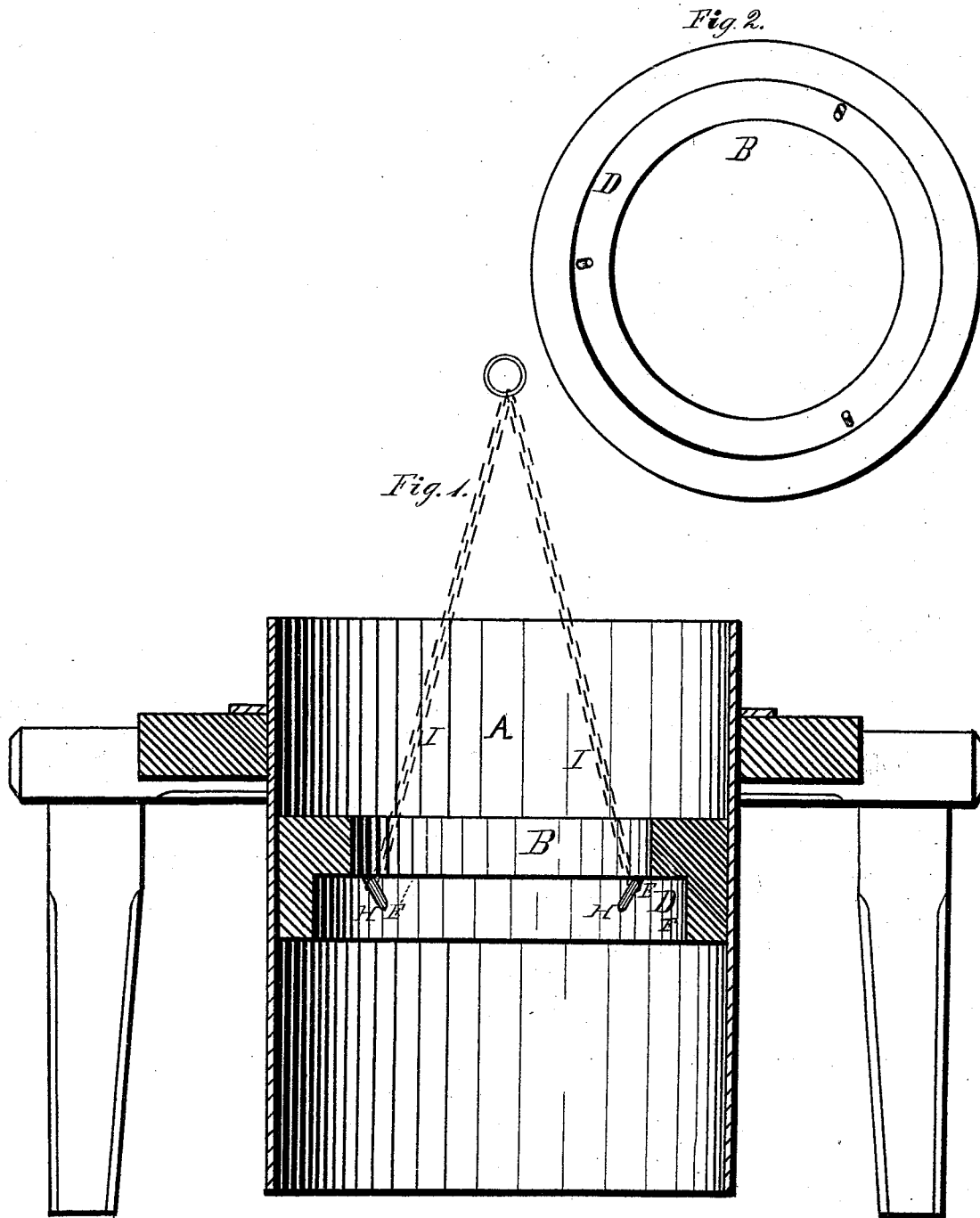

Witnesses,
Chas. Clill
D. Fowl.

Inventor,
William Kemple
by his Attys.
Cox & Cox.

UNITED STATES PATENT OFFICE.

WILLIAM T. KEMPLE, OF SEDALIA, INDIANA.

IMPROVEMENT IN CONSTRUCTION OF WELLS.

Specification forming part of Letters Patent No. 184,388, dated November 14, 1876; application filed September 27, 1876.

To all whom it may concern:

Be it known that I, WILLIAM T. KEMPLE, of Sedalia, in the county of Clinton and State of Indiana, have invented a new and useful Improvement in the Construction of Wells, of which the following is a specification, reference being had to the accompanying drawings.

The invention relates to an improvement in the construction of wells; and consists in the devices hereinafter specifically designated, the object being to provide an efficient means of walling wells from above.

Figure 1 is a central vertical longitudinal section of a device embodying the elements of the invention. Fig. 2 is a bottom view of the carrier.

In the accompanying drawings, A represents the walls of an ordinarily-constructed well before being bricked. B represents a carrier constructed of a durable piece of material, which is designed to conform with the sides of the well, and may be of any suitable dimensions, its lower inner edge being cut away, so as to form the re-entrant angle D, composed of the horizontal side E and perpendicular side F. In the horizontal side E are driven at equal distances the spikes H, which are either bent or placed on an incline, all of their heads extending toward the vertical center of the aperture in the center of the carrier, so that when the carrier has permanently reached the bottom of the well the chains

I, which have now become slackened, can slip off the spikes and be again raised to the surface. These chains unite at a suitable point above the well, and are operated by a derrick.

The well being dug and the derrick placed over the same, the carrier B is inserted in the well about the distance of the thickness of one layer of brick and the chains attached to retain it in position. A layer of brick is then placed on the carrier, which is now let down the well by the derrick about the distance of the thickness of two layers of brick, after which another layer of brick is added, and the carrier again let down the well, this alternate operation being continued until the carrier has reached the bottom of the well. The chains are then allowed to slip off the spikes and are raised to the surface, the carrier remaining down the well.

What I claim as my invention, and desire to secure by Letters Patent, is—

The carrier B, having the re-entrant angle D, and provided with the pins H, in combination with the chains I, substantially as and for the purpose specified.

In testimony that I claim the foregoing improvement in the construction of wells, as above described, I have hereunto set my hand.

WILLIAM T. KEMPLE.

Witnesses:

MANFORD A. SHIELDS,
HUGH SHIELDS.