

M. B. MASSEY.

IMPLEMENTS FOR CRIMPING CARTRIDGES.

No. 184,403.

Patented Nov. 14, 1876.

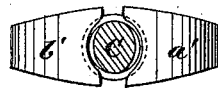
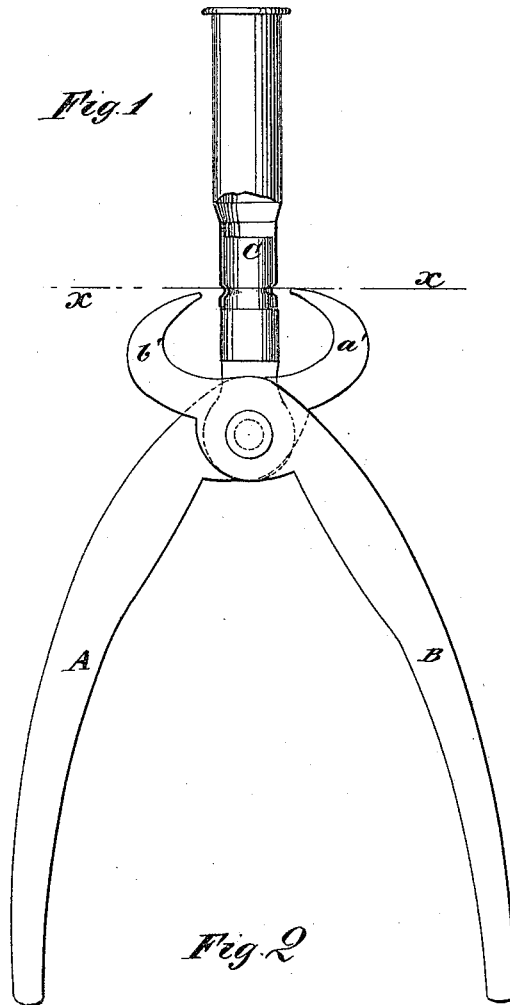

WITNESSES:

*A. W. Almquist*  
*J. H. Scarborough*

INVENTOR:

*M. B. Massey*

BY

*Wm. H. [Signature]*  
ATTORNEYS.

# UNITED STATES PATENT OFFICE.

MORDECAI B. MASSEY, OF HUNTINGDON, PENNSYLVANIA.

## IMPROVEMENT IN IMPLEMENTS FOR CRIMPING CARTRIDGES.

Specification forming part of Letters Patent No. 184,403, dated November 14, 1876; application filed October 14, 1876.

*To all whom it may concern:*

Be it known that I, MORDECAI B. MASSEY, of Huntingdon, in the county of Huntingdon and State of Pennsylvania, have invented a new and useful Improvement in Instrument for Beading Cartridge-Shells, of which the following is a specification:

Figure 1 is a side view of my improved instrument, illustrating its use. Fig. 2 is an end view of the same, partly in section through the line *x x*, Fig. 1.

Similar letters of reference indicate corresponding parts.

The object of this invention is to furnish an instrument for beading, creasing, or grooving cartridge-shells that have been expanded by being used, so that when the shell is reloaded the ball will be held in place without being liable to drop out.

The invention consists in the combination of the grooved cylinder with the nippers, provided with semicircular notches in the edges of its jaws, to adapt it for use, as hereinafter fully described.

A B are two handles, the forward ends of which are pivoted to each other, and which project beyond the pivot, and are curved inward to form jaws *a' b'*. As thus far described, the instrument is exactly like a pair of nippers. The edges of the jaws *a' b'* have semicircular notches formed in them to fit upon the cylinder C, the inner end of which is flattened, is inserted between the parts of the nippers A

B, and is pivoted to the pivot that pivots the parts of said nippers to each other. The cylinder C is made a little smaller than the interior of a cartridge-shell, so that a shell may be slipped on and off it easily. In the sides of the cylinder C is formed a groove directly opposite the concaved edges of the jaws *a' b'*.

In using the instrument the empty shell is slipped upon the cylinder C, and the jaws *a' b'* are closed upon it by pressing the handles A B toward each other, and the shell is turned around with the hand, forming a groove, crease, or inwardly-projecting bead around the shell, so as to hold the ball securely in place when inserted in said shell. The concaved edges of the jaws *a' b'*, and the groove in cylinder C, may be so formed as to form a groove of any desired breadth in the shell; or they may be so formed as to form two or more grooves in the said shell, as may be desired.

Having thus described my invention, I claim as new and desire to secure by Letters Patent—

The combination of the grooved cylinder C with the nippers A B, provided with semicircular notches in the edges of its jaws *a' b'*, to adapt it for use, substantially as and for the purpose herein set forth and described.

MORDECAI B. MASSEY.

Witnesses:

JAMES T. GRAHAM,  
C. SEDGWICK.