

T. K. STIDHAM.
RECLINING CHAIR.

No. 184,438.

Patented Nov. 14, 1876.

Fig. 1.

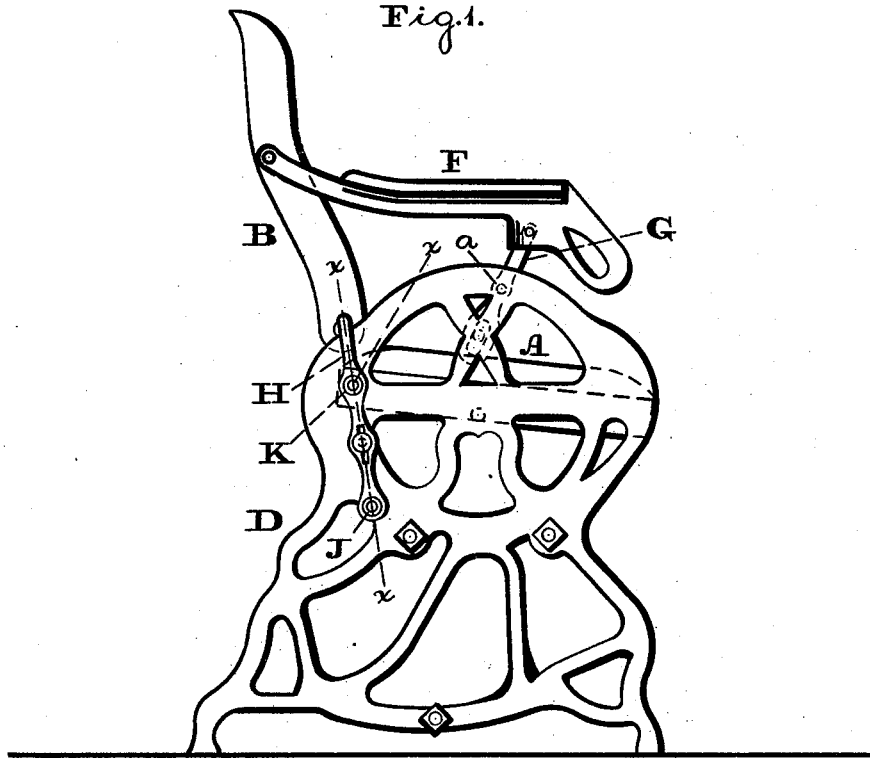
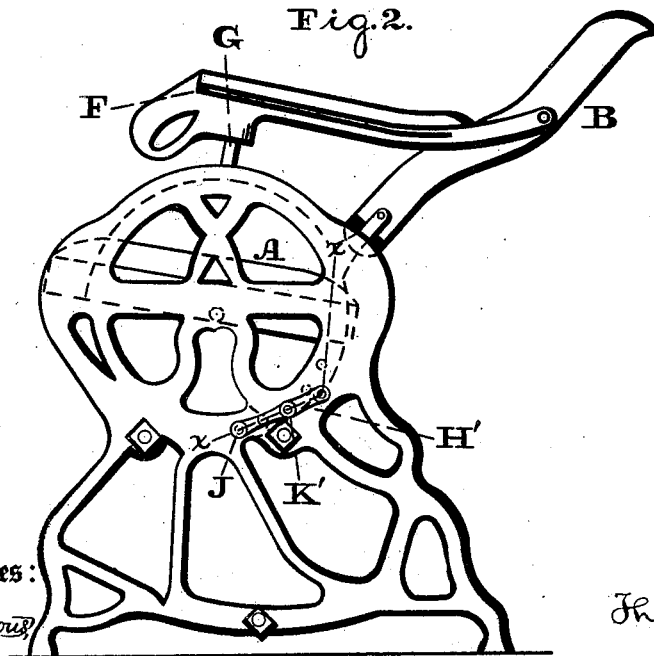

Fig. 2.



Witnesses:
Lewis F. Brown
A. P. Grant

Inventor:
Thos. K. Stidham

by *Johel Diederheim*
 Attorney.

T. K. STIDHAM.
RECLINING CHAIR.

No. 184,438.

Patented Nov. 14, 1876.

Fig. 3.

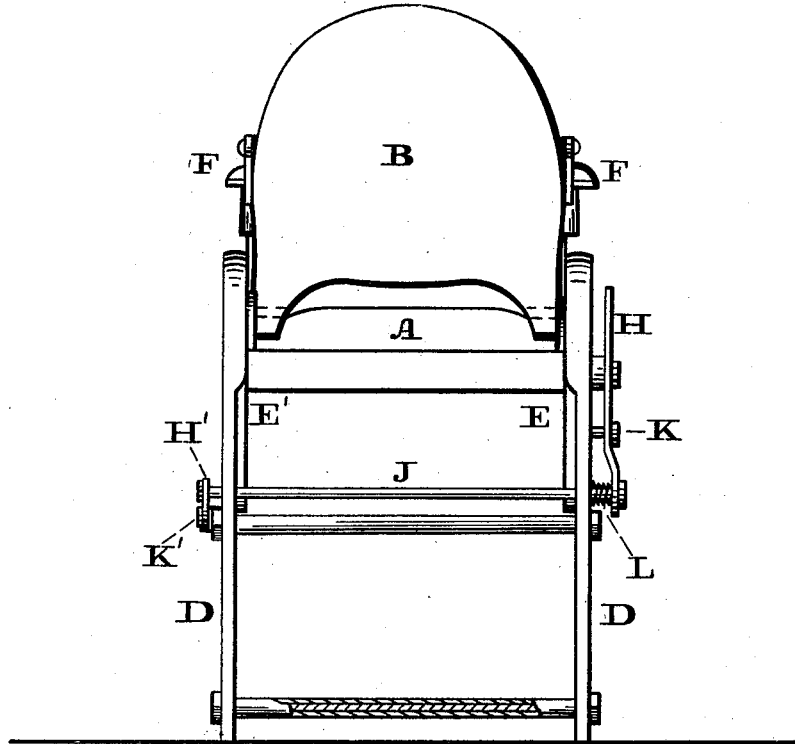

Fig. 4.

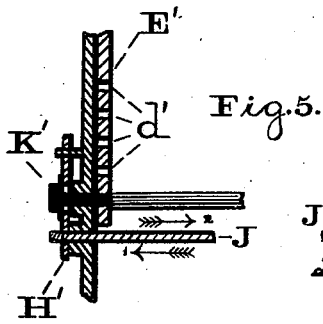
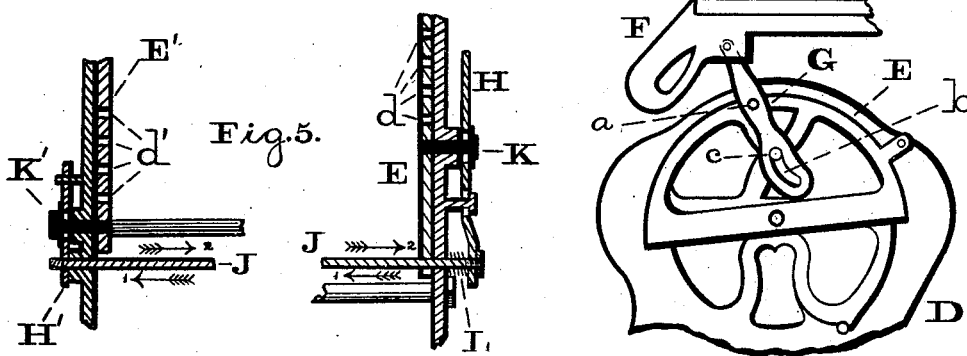

Fig. 5.

Witnesses:
Lewis C. Brown,
Ac. P. Grant.

Inventor:
Thos. K. Stidham.
by *John A. Gunderheim,*
Attorney.

UNITED STATES PATENT OFFICE.

THOMAS K. STIDHAM, OF PHILADELPHIA, PENNSYLVANIA, ASSIGNOR OF
ONE-HALF HIS RIGHT TO SAMUEL S. WHEELER, OF SAME PLACE.

IMPROVEMENT IN RECLINING-CHAIRS.

Specification forming part of Letters Patent No. **184,438**, dated November 14, 1876; application filed
April 1, 1876.

To all whom it may concern:

Be it known that I, THOMAS K. STIDHAM, of the city and county of Philadelphia, and State of Pennsylvania, have invented a new and useful Improvement in Recumbent Chairs; and I do hereby declare the following to be a clear and exact description of the nature thereof, sufficient to enable others skilled in the art to which my invention appertains to fully understand, make, and use the same, reference being had to the accompanying drawings, making part of this specification, in which—

Figures 1 and 2 are views of opposite sides of the chair, embodying my invention. Fig. 3 is a rear view thereof. Fig. 4 is a view of the innerface of one of the sides of the chair. Fig. 5 is a transverse section in lines *x x*, Figs. 1 and 2.

Similar letters of reference indicate corresponding parts in the several figures.

My invention consists of the seat and back moving together, the former being attached to rotary segmental pieces, and the latter being pivoted thereto, which segments are guided in the side pieces of the frame of the chair, in connection with arm-rests which are pivoted to the back, and to arms whose axes are on the segmental pieces, said arms also having slots through which project guiding pins or studs on the side pieces of the frame.

It also consists of means for simultaneously locking and unlocking the segmental side pieces for purposes of adjustment of the seat.

Referring to the drawings, A represents the seat, B the back, and D the supporting-frame, of the chair. The seat A is pivoted to the sides of the upper portions of the frame D, and to the sides of the seat there are secured segmental pieces E E', which are fitted in spaces on the inner faces of the upper portions of the frame D, the upper walls of the spaces being of circular form, so as to correspond with the adjacent peripheries of the segments. The side pieces of the back B are pivoted to the segments, and to the back there are pivoted the arm-rests F, whose forward ends are supported on and connected to the upper ends of arms G, whose axes *a* are on the segments, and whose lower ends are slotted, as at *b*, in the direction of the length of the arms, said slots being preferably of curved

form, and through the same project pins or studs *c*, which are secured to and extend horizontally inward from the upper portions of the frame D. To one side of the frame D there is pivoted a lever, H, and to the opposite side there is pivoted a lever, H', the two levers being connected by a rod, J, which extends from side to side of the frame, beneath the seat A, so that the movement of the lever H will move the lever H'. To the lever H there is secured a pin or stud, K, which passes through the side of the frame D, so as to engage with notches *d* on the segment E, and to the other lever H' there is secured a pin or stud, K', which passes through the respective side of the frame D, so as to engage with notches *d'* on the segment E'. L represents a spring, which bears against the levers H or H', or against the rod J, for restoring the levers to their normal position, and causing the pins K K' to engage with the respective notches *d d'*.

The operation is as follows: When the seat and back are to be placed in a recumbent position the lever H is forced outward. This draws the pin K from the notch *d*, with which it previously engaged, and, owing to the rod J connecting the levers H H', the lever H' is forced outward, whereby the pin K' will be drawn from the notch *d'*, with which it previously engaged. The segments E E' thus being released the back B will be moved rearward to the desired extent, and the seat A will follow its motions. The lever H is then let go, and, owing to the spring L, the pins K K' drop into the relative notches of the segments, and thus the back and rear will be securely held in the adjusted position.

The back and seat may be restored to their normal position by operating the lever H so as to release the segment and move the back forward, the seat following the movement.

The forward ends of the arm-rests F are jointed to the arms G, as has been stated, and, owing to the slotted connections of the lower ends of the arms with the studs or pins *c*, said rests are caused to assume relative positions to the back and seat, and their forward ends will be properly supported, the slots *b* of the arms permitting the fullest motions of the arms, and, consequently, of the back, the back folding out to a greater extent than the seat,

and thus causing the back and seat to present the most comfortable positions.

Having thus described my invention, what I claim as new, and desire to secure by Letters Patent, is—

1. The seat A, fixed to the segments E E', and the backs B, pivoted to said segments, in combination with the pivoted arm-rests F, and with the arms G, pivoted to segments, and having slotted connections with the frame D, substantially as and for the purpose set forth.

2. The recumbent seat and back with the notched segments E E', in combination with the levers H H', connecting-rod J, and pins or studs K K', substantially as and for the purpose set forth.

THOMAS K. STIDHAM.

Witnesses:

JOHN A. WIEDERSHEIM,
A. P. GRANT.