

C. S. CUSHMAN.
SEWING-MACHINE.

No. 184,594.

Patented Nov. 21, 1876.

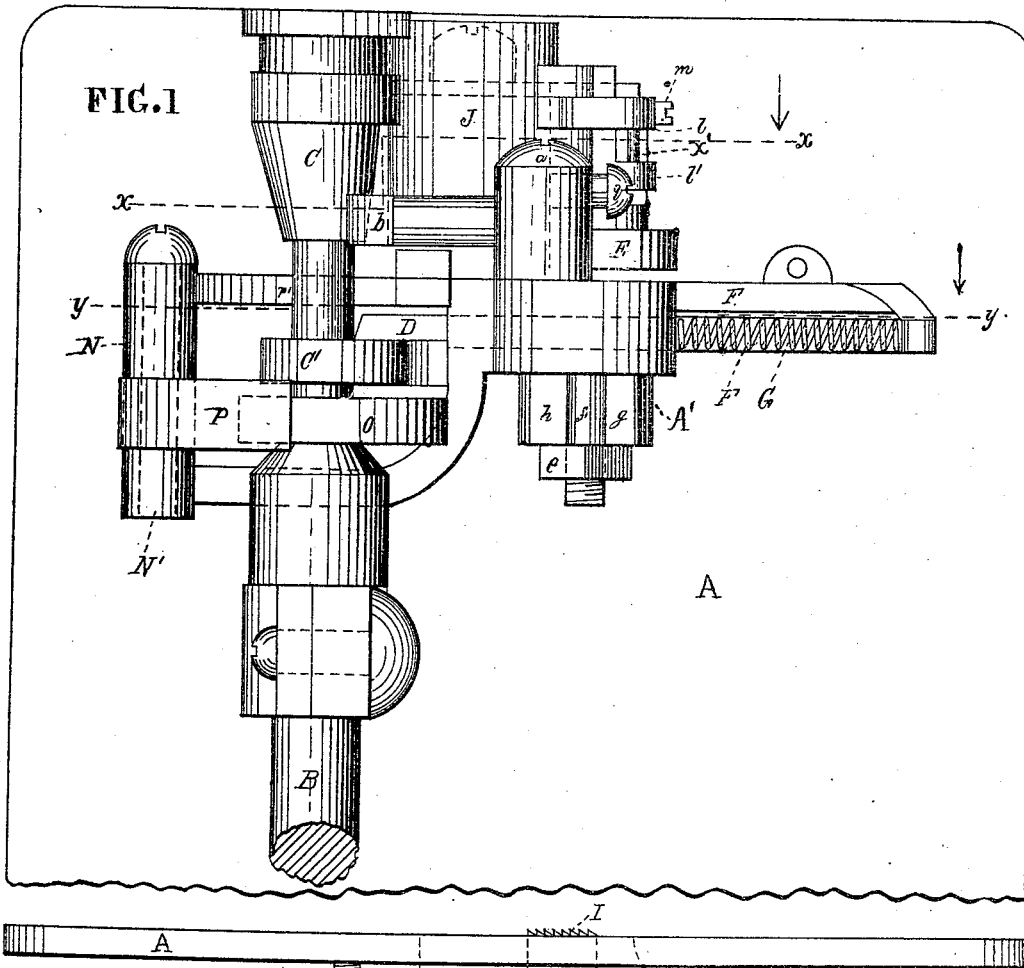
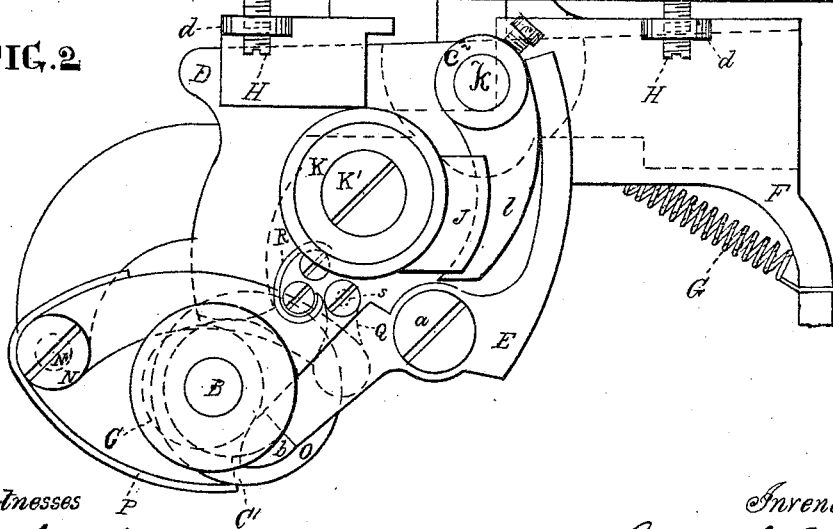

FIG. 2



Witnesses
 Thomas J. Dewley,
 Joseph S. Shaheen

Inventor
 Cyrus S. Cushman
 Stephen Notick Attorney.

UNITED STATES PATENT OFFICE.

CYRUS S. CUSHMAN, OF PHILADELPHIA, PENNSYLVANIA, ASSIGNOR TO
NESBITT D. STOOPS, OF SAME PLACE.

IMPROVEMENT IN SEWING-MACHINES.

Specification forming part of Letters Patent No. 184,594, dated November 21, 1876; application filed
December 10, 1874.

To all whom it may concern:

Be it known that I, CYRUS S. CUSHMAN, of Philadelphia, in the county of Philadelphia and State of Pennsylvania, have invented certain new and useful Improvements in Sewing-Machines, of which the following is a specification:

This invention relates to certain improvements in the feed mechanism of sewing-machines, its object being to provide a feed-movement capable of a forward or progressive motion and a simultaneous lateral motion, for the purpose of zigzag or ornamental stitching, and which will be readily interchangeable with the ordinary feed-movement of the sewing machines in ordinary use, so that by its employment such machines may be used at pleasure for plain or fancy stitching.

My invention consists, first, in a removable frame or hanger for carrying or supporting the various devices of a feed-movement, or, if desired, of a compound feed-movement, said frame or support being constructed and adapted to be secured to the stationary hanger or abutments below the bed-plate of the machine, and capable of adjustment in relation to said plate by means of set-screws, whereby all may be leveled, as hereinafter more fully set forth; second, in the combination, with the driving-shaft of a sewing-machine, of mechanism or devices for imparting a lateral reciprocating motion to the feed-plate; third, in the combination, with the driving-shaft of the machine, of devices or mechanism for imparting a combined backward and forward and lateral reciprocating motion to the feed-plate, as more fully hereinafter set forth and described; and, fourth, in certain combinations of various parts for operating the feed-plate, all of which will be more fully hereinafter set forth and described.

In the drawings, Figure 1 is a bottom view of the front end of the bed-plate with my improvements attached. Fig. 2 is an elevation of the front end of the bed-plate and my improved feed-movement. Fig. 3 is a detached elevation of the frame and devices constituting my improved feed-movement. Fig. 4 is a top view of the same. Fig. 5 represents a view of the front end of the machine, showing my improved feed-movement partially in elevation and partially in section, taken on the line *x x*

of Fig. 1, and looking in the direction of the arrows. Fig. 6 represents an elevation of the machine, with a portion of the feed devices removed, showing the devices for imparting the forward or progressive movement of the feed-plate, taken on the line *yy* of Fig. 1, and looking in the direction of the arrows. Figs. 7 and 8 are detached views of the lever by which the forward rectilinear movement is given to the sliding bar which carries the feed-plate. Figs. 9 and 10 are detached views of the cam which is employed for imparting the lateral movement to the feed-plate, and Figs. 11 and 12 are detached views of the sleeve which slides on the cam *J* and transmits the lateral movement to the feed-surface.

The letter *A* represents the bed-plate of the machine, and *A'* the stationary or permanent hanger or abutment formed thereon or attached thereto. *F* represents a removable frame or hanger, upon which the various working parts of my improved feed-movement are supported, with the exception of the cams secured upon the driving-shaft. Said frame or hanger is provided with a screw-bolt, *f*, which is adapted to set between the jaws *h g* of the permanent hanger *A'* of the machine, and be confined therein by a screw-nut, *e*, by means of which the movable hanger is securely fastened in place, the same being capable of being readily attached and detached, in order that either the ordinary feed-movement of the machine or the improved compound feed-movement may be employed at pleasure. *H H* represent two set-screws, setting through lugs *d d* on the upper part of the movable hanger *F*, the ends of which bear against the lower surface of the bed-plate *A*, and by means of which the removable hanger or frame and the various parts of the feed-movement may be leveled and adjusted to the proper position in relation to the bed-plate and the work. *B* is the driving-shaft, which has on its front end a feed-cam, *C*, for giving the forward movement to the feed-bar *D*, the cam operating the said bar by means of the lever *E*, hung on the fulcrum-pin *a*, which projects from the front side of the frame *F*. The upward movement is given by means of the cam *C'*. The said frame *F* and parts in connection are shown detached from the machine in Figs. 3 and 4. The swivel *b* on the front end of the

lever E is kept up against said conical cam by the action of the wire spring G, connected with the feed-bar, pulling the stud c^2 of the bar against the end of the lever, so that the cam may give the forward movement to the feed-bar, and the spring the backward movement.

The front end of the feed-bar is hung on the fulcrum-pin i , which passes through the slot j of the bar, and is screwed into the frame F. The other end is held by the pin i' , which passes through the slot j' , which is of proper dimensions to admit of the forward, back, and vertical movements of the bar.

The feed-surface I is separate from the feed-bar, and has a stem, k , which has a sliding movement in the above-mentioned lug c^2 , to provide for a lateral movement of the feed-surfaces simultaneously with its forward movement, given by the forward movement of the feed-bar, whereby a zigzag or ornamental stitching is produced. On the outer end of the stem k of the feed-surface I there is an arm, l , adjustable for the purpose of adjusting the lateral movements of the feed-surface, being held by means of the screw m , and an arm, l' , connected therewith by means of a pin, x' , for the purpose of holding the feed-surface in a vertical position. The outer end of said arm is held in the cross-groove n of the sleeve J, which surrounds the cylinder K on the stem k' .

The cylinder has a circumferential cam-groove, p , on its inner end, into which the pin q of the sleeve J projects, and also has a ratchet-wheel, L, whereby, as the cylinder is revolved by an intermittent movement of the spring-detent M, a longitudinal movement on the cylinder J is given to the sleeve, and thereby a reciprocating lateral movement to the feed-plate I, simultaneously with its forward movement, to produce ornamental stitching.

N is a hollow rocking shaft on the stem N' , which projects laterally from the front end of the frame F. A rotary reciprocating movement is imparted to this shaft by means of the cam O on the driving-shaft, in combination with the spring P. The heel of the spring is fast to the rocking shaft, and the resilient end bears upon said cam-wheel, whereby the outer end of the short arm r of the shaft is kept against the cam. The rocking shaft has a long arm, r' , for giving a quick movement to the ratchet-wheel L of the cylinder K, for giving rapidity to the lateral movement of the feed-plate I through the parts above described, as the lateral movement each way must be made in the length of time in which the forward movement is given. To the outer end of said long arm r' is pivoted one end of the link Q, the other end of which, by means of the pivot s , is connected to one end of the plate R, hung on the hub of the ratchet-wheel L, which has a spring-detent, M, which engages with the ratchet-wheel L, above mentioned, to give an intermittent rotary movement to the cylinder J, which, by acting

through the intermediate above described, gives the lateral movement to the feed-plate I.

Having thus described my invention, what I claim, and desire to secure by Letters Patent, is—

1. In combination with the bed-plate of a sewing-machine, a movable frame or hanger, adapted to support the whole or a portion of the compound feed-movement of the machine, and adjusting-screws, whereby the said feed-movement may be applied to a machine, leveled and adjusted in place with respect to the said bed-plate, or be entirely removed therefrom, in a manner substantially as described.

2. The combination, substantially as hereinbefore set forth, of the driving-shaft and cam thereon, and the reciprocating feed-bar, sliding feed-plate bar, provided with a downwardly-projecting arm, operated by said cam, and connecting mechanism, for imparting a vertical reciprocating motion to the feed-plate, substantially as described.

3. The combination, substantially as described, with the driving-shaft and cam thereon, of the oscillating lever, adapted to be operated by said cam, the pawl-lever and pawl, connected to said oscillating lever, the ratchet-wheel operated thereby, the rotating cam-wheel, attached to said ratchet-wheel, the laterally-sliding sleeve, operated by said cam-wheel, and the downwardly-projecting finger, working in the slot in said sleeve, and attached to the sliding stem, to which the feed-plate is attached, for the purpose of imparting a lateral reciprocating motion to the feed-plate, substantially as set forth.

4. The combination, substantially as herein described, of the driving-shaft and its cams, the levers for operating the feed-plate bar and the pawl-lever, pawl and ratchet-wheel, the rotating cam and sliding sleeve, the projecting finger and sliding stem or feed-plate shaft, and the feed-plate bar, the whole constructed and arranged to operate substantially as herein set forth.

5. The combination of the feed-lever E with the detachable frame F, feed-cam C, and feed-bar D, having the laterally-reciprocating feed-plate, substantially as set forth.

6. The feeding-plate I, having a stem, k , in combination with the feed-bar D, having a bearing, in which said stem has a reciprocating movement, produced by suitable mechanism, at right angles to the line of movements of the feed-bar, to produce ornamental stitching, substantially as set forth.

7. The hollow rocking shaft N' , having arms r r' , in combination with the detachable frame F, having a stem, N, on which the rocking shaft oscillates, and swivel-plate R, having the detent N, for giving a reciprocal lateral movement to the feed-plate, substantially as set forth.

CYRUS S. CUSHMAN.

Witnesses:

THOMAS J. BEWLEY,
STEPHEN USTICK.