

J. PASSMORE.
MARBLE MANTEL CLAMPS.

No. 184,659.

Patented Nov. 21, 1876.

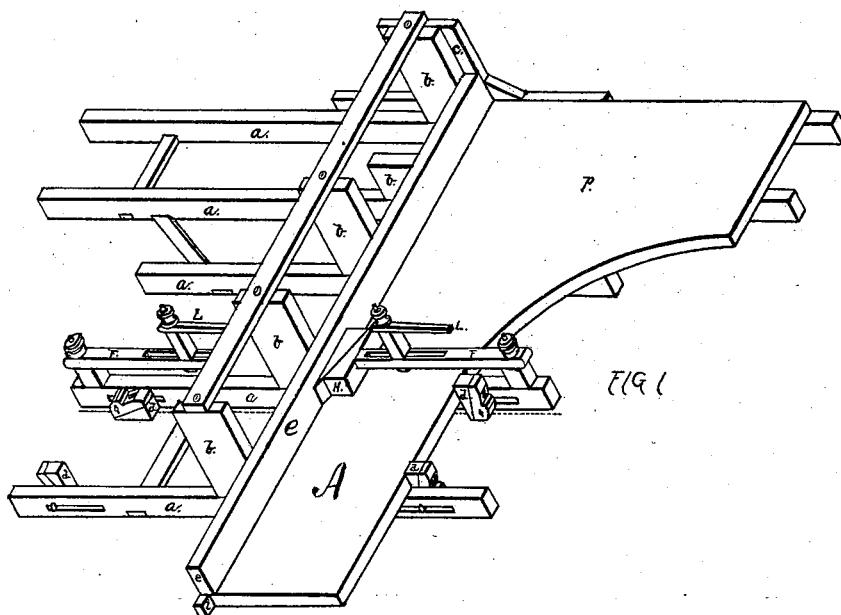
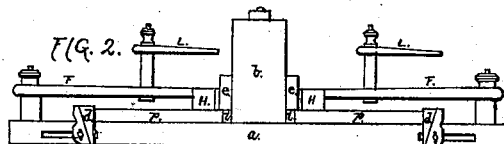
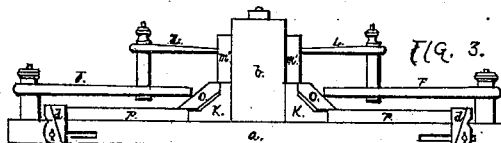

WITNESSES

Mr. M. Lopez
Wm. C. Clark

INVENTOR

John Passmore

UNITED STATES PATENT OFFICE.

JOHN PASSMORE, OF NEWARK, NEW JERSEY.

IMPROVEMENT IN MARBLE-MANTEL CLAMPS.

Specification forming part of Letters Patent No. 184,659, dated November 21, 1876; application filed June 1, 1876.

To all whom it may concern:

Be it known that I, JOHN PASSMORE, of Newark, in the county of Essex and State of New Jersey, have invented a certain clamp for putting together at the same time right and left hand sections of marble, slate, and other mantels, of which the following is a specification:

My invention consists in a frame and a combination of devices for holding the sections of a mantel, right and left hand, while they are being put together and cemented for use.

Figure 1 is a perspective view, and shows a mantel put together with a square profile. Fig. 2 is a cross-section of the same. Fig. 3 is a cross-section, and shows a mantel put together with a bevel profile.

The frieze-sections *A* of a mantel are laid on the bed-piece or frame *a*, and are squared by the standards *b* and the head-piece *c*, and are held in place by the wedge-buttons *d*. These buttons slide in a slot in a section of the frame, and are tightened when in position by a thumb-screw. The wedge slides in a slot in the button, and is pressed down closely between the button and the section *A*, thus holding it very firmly.

In putting together a mantel with a square profile, as shown in Figs. 1 and 2, the section *A* is laid on the frame, and the profile *e* put in position against the standards, and is held in place by the swinging arms *F* and the double wedges *H*. The arms swing on a post attached to the frame. *i* is a corner gage or strip put in on the frame for the purpose of showing the edges of the square profile. Fig. 1 shows a right-hand section of a mantel put together, and on the other side of the standards is a place where the left-hand section may be put together. Figs. 2 and 3 show the right and left hand sections on the clamp.

When desirable to build up a corner with a bevel profile, *o*, as seen in Fig. 3, in the place of the strips or corner gages *i*, I use the double-section gages *K*, to show the projections of the bevel *O* and square profile *M*. These double-section gages *k* and the gages *i* may be changed to suit different forms of profile with the same result, and to meet these changes the swinging arms may vary in their order of working. The bevel profile *O* is held in position by the swing-arms *F*, and the square profile *M* by an added swing-arm, *L*. This arm is hung to a part adjusted by a thumb-screw to the arm *F*.

In the use of these devices the sections of a mantel—right and left hand—are put together and held until they are properly bound by cement or other means, and are in condition to be put in their place in a building.

I claim in a clamp for mantels—

1. The frame *a*, with the standards *b* and head-piece *c*, arranged for right and left hand work, substantially as and for the purposes specified.
2. In combination with the frame *a*, the wedge-buttons *d*, substantially as and for the purpose set forth.
3. In combination with the frame *a*, the swing-arms *F* and the wedges *H*, substantially as and for the purposes named.
4. In combination with the arms *F*, the swing-arms *L*, substantially as and for the purposes specified.
5. In combination with the frame *a*, the double-section gages *K* or the gages *i*, suited to the bevel or square profile, substantially as and for the purposes set forth.

JOHN PASSMORE.

Witnesses:

WM. M. LOREE,
WM. C. CLARK.