

C. B. WINANS.

COMBINED PETTICOAT PIPE AND FEED-WATER HEATER.

No. 184,682.

Patented Nov. 21, 1876.

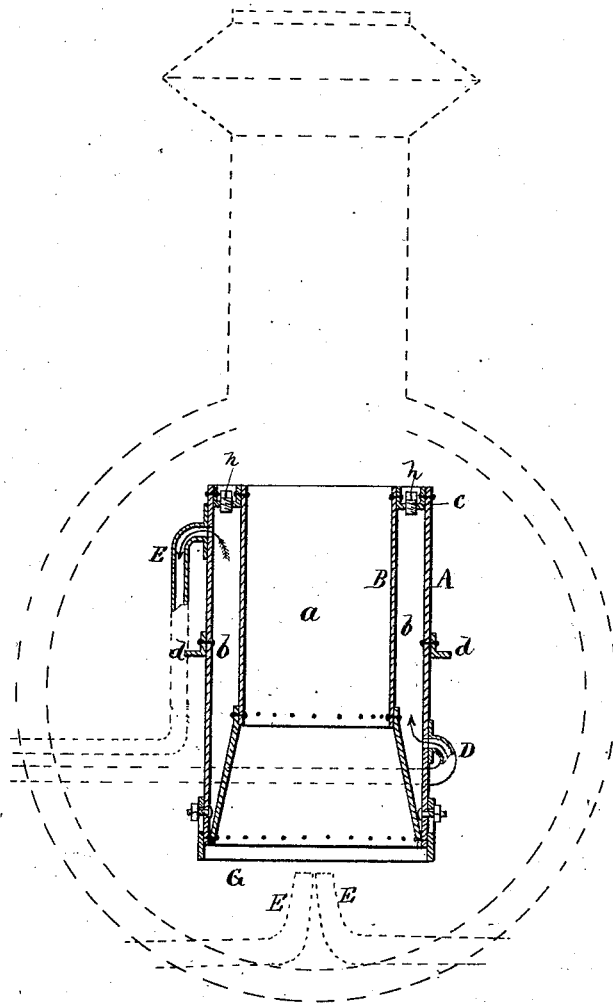

WITNESSES

Henry N. Miller
C. L. Ewert,

INVENTOR

Chas. B. Winans.
Alexander Mason
ATTORNEY

UNITED STATES PATENT OFFICE.

CHARLES B. WINANS, OF LINCOLN, ILLINOIS.

IMPROVEMENT IN COMBINED PETTICOAT-PIPE AND FEED-WATER HEATER.

Specification forming part of Letters Patent No. **184,682**, dated November 21, 1876; application filed August 29, 1876.

To all whom it may concern:

Be it known that I, CHAS. B. WINANS, of Lincoln, in the county of Logan and in the State of Illinois, have invented certain new and useful Improvements in Combined Petticoat-Pipe and Feed-Water Heaters; and do hereby declare the following is a full, clear, and exact description thereof, reference being had to the accompanying drawings and to the letters of reference marked thereon, making a part of this specification.

The nature of my invention consists in the construction and arrangement of a combined petticoat-pipe and feed-water heater for locomotives, as will be hereinafter more fully set forth.

In order to enable others skilled in the art to which my invention appertains to make and use the same, I will now proceed to describe its construction and operation, referring to the annexed drawing, in which the figure represents a vertical section of my invention, showing by dotted lines its position under the smoke-stack of the locomotive.

A represents the outer cylindrical shell, and B the inner shell or petticoat-pipe. This inner shell is made cylindrical from the upper end downward for a suitable distance, and the lower end is made conical, so that the lower edges of the two shells will be united together, as shown, while the upper ends of the two shells are connected by an annular head, C. By this construction of the device a central steam and smoke space, *a*, is formed, and between the shells is the water-space *b*. The petticoat-pipe also forms the inner wall of the feed-water heater. D is the inlet for the water, and E is the outlet for the same. At the bottom of the heater is a circumferential band, G, made adjustable up and down, and held by means of bolts passing through vertical

slots in the band. *dd* are simply lugs to keep the heater in its place in the smoke-arch of the locomotive. The pipes D E should be connected with the heater by union couplings, so that the heater can be taken out of the smoke-arch at any time by loosening said couplings for the purpose of gaining access to the flues or otherwise, as may be required. The heater is placed in the position, as shown in the drawing, directly over the exhaust-steam pipes E E, whereby it performs the combined function of a petticoat-pipe and a feed-water heater.

The object of the invention is to utilize the waste heat of combustion and exhaust steam to heat the water before entering the boiler. It is no impediment to the draft, and by means of the adjustable band G at the bottom it will give more or less draft, as may be required. For the purpose of cleaning the heater there are plugs *h h* in the head C, which can readily be taken out and replaced again.

I do not broadly claim a water-heater within the smoke box or chimney of a boiler.

Having thus fully described my invention, what I claim as new, and desire to secure by Letters Patent, is—

The petticoat-pipe B, surrounded by wall A, forming water-chamber *b*, in combination with eduction and induction pipes D E, and the adjustable band G, all constructed substantially as and for the purposes herein set forth.

In testimony that I claim the foregoing I have hereunto set my hand this 4th day of August, 1876.

CHARLES B. WINANS.

Witnesses:

C. C. BRACKETT,
DAVID HUMMELL.