

J. F. KELLOGG.

TUCK-MARKER.

No. 184,715.

Patented Nov. 28, 1876.

Fig. 1.

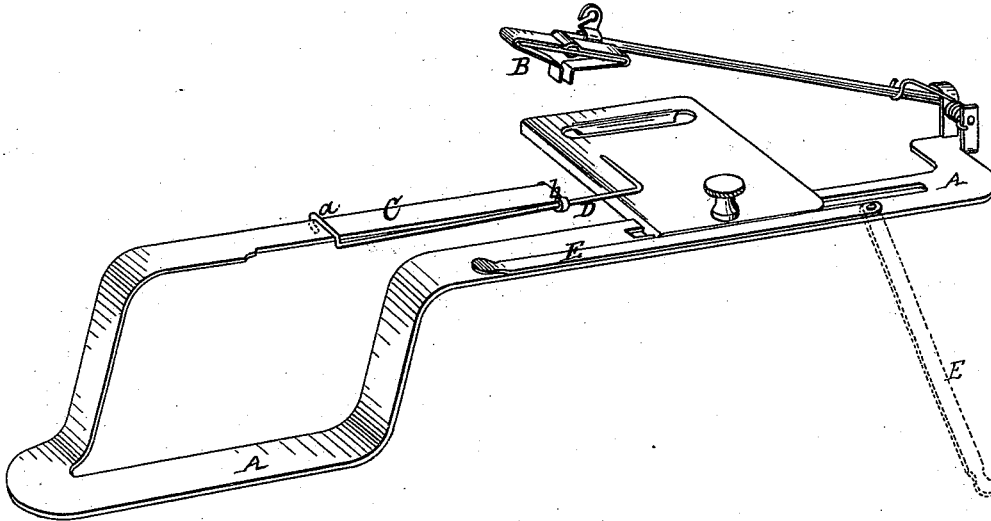
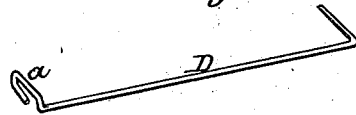

Fig. 2.



Witnesses:  
Philip J. Garner  
A. B. Cauldwell

Inventor:  
James Franklin Kellogg  
By [Signature]  
[Signature]  
Attorney

# UNITED STATES PATENT OFFICE.

JAMES F. KELLOGG, OF FORESTVILLE, NEW YORK.

## IMPROVEMENT IN TUCK-MARKERS.

Specification forming part of Letters Patent No. 184,715, dated November 28, 1876; application filed August 25, 1875.

*To all whom it may concern:*

Be it known that I, JAMES FRANKLIN KELLOGG, of Forestville, in the county of Chautauqua, in the State of New York, have invented certain new and useful Improvements in Tuck-Markers; and I do hereby declare that the following specification, taken in connection with the drawings furnished and forming a part of the same, is a clear, true, and complete description thereof.

My said improvements are applicable to tuck-markers in general, regardless of the special means employed for making the line or crease, and one feature thereof relates particularly to a peculiar construction of the gage; and another feature relates to a peculiarly-mounted smoothing-plate.

One feature of my invention consists in the combination, with the tuck-marker arm, of a gage composed of spring metal, the shank of which is bent around and caused to frictionally embrace the arm or plate over which the fabric passes while being subjected to the action of the creasing device, in order that it may readily be set at any desired point, and there retained without the use of a set-screw or other similar device, as heretofore employed with such gages.

The other feature of my invention consists in the combination, with a tuck-marker, of a smoothing-plate, which is pivoted to the frame of the marker, and arranged to swing outward and away therefrom, prior to the placing of the fabric in position, and to thereafter be returned, so as to smooth the same as it is moved along during the making operation.

Referring to the drawings, Figure 1 represents, in perspective, a tuck-marker embodying my improvements. Fig. 2 represents the gage detached.

A denotes the frame of the marker, which is arranged to be applied to the cloth-plate of a sewing-machine in the usual manner. B denotes a well-known creasing device, and C denotes the arm or plate over which the fabric passes. D denotes the gage. As heretofore constructed, it has been rendered longitudinally adjustable by means of a set-screw.

In accordance with my invention the gage is composed of spring metal, and at the rear end it is bent laterally and returned upon itself, so as to form a clamp, as at *a*, which embraces the arm C with frictional contact, so that whether the gage be well advanced for a wide tuck or adjusted for a narrow one, it will be held firmly in position. This gage can readily be set, and is much more convenient than a set-screw or equivalent device, and in practice it is amply reliable. The gage passes through an eye at the edge of the arm, as shown at *b*. E denotes the smoothing-plate, which smooths the fabric as it passes to the marker. As heretofore constructed, the smoothing-plate has been fixedly riveted to the frame, and capable of being raised at the end, in order that the cloth may be passed under it when placed in proper position to be creased. In order that this may be more conveniently done, I pivot my plate at its rear end, so that it may be swung outward and to the rear, as indicated by the dotted lines, when the fabric is to be put into proper position, and then it is returned, so as to press upon and smooth the cloth. By having the smoothing-plate out of the way and wholly free from the fabric, the operative can employ both hands in adjusting the fabric, and it can thereby be much more readily adjusted than with a plate, which presses thereon, as heretofore constructed.

Having thus described my invention, I claim as new—

1. The combination, with a tuck-marker arm, of a gage composed of wire, and having at its rear end a clamp, formed by bending the wire, which embraces and frictionally engages with the arm of the marker, substantially as described.

2. In combination with a tuck-marker, the swinging smoothing-plate pivoted to the frame of the marker, substantially as described.

JAMES FRANKLIN KELLOGG.

Witnesses:

W. M. COOMBS,  
H. S. PERRY.