

S. JACKSON.

YARN-WINDING REGULATOR FOR SPINNING-MULES.
No. 184,782. Patented Nov. 28, 1876.

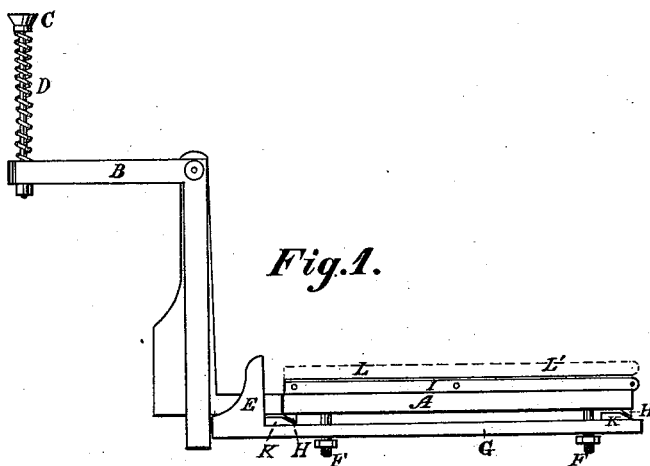

Fig. 1.

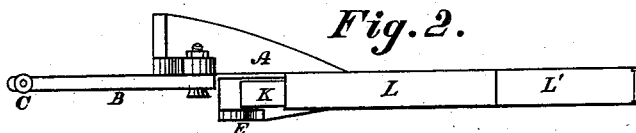

Fig. 2.

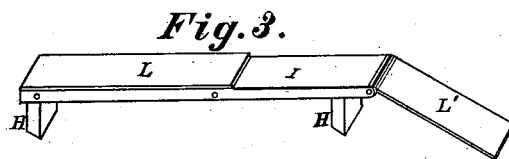

Fig. 3.

Witnesses;

W. Harmon
Audm. Stone

Inventor;

Samuel Jackson
Per Charles D. Moore
Att'y.

S. JACKSON.

YARN-WINDING REGULATOR FOR SPINNING-MULES.

No. 184,782.

Patented Nov. 28, 1876.

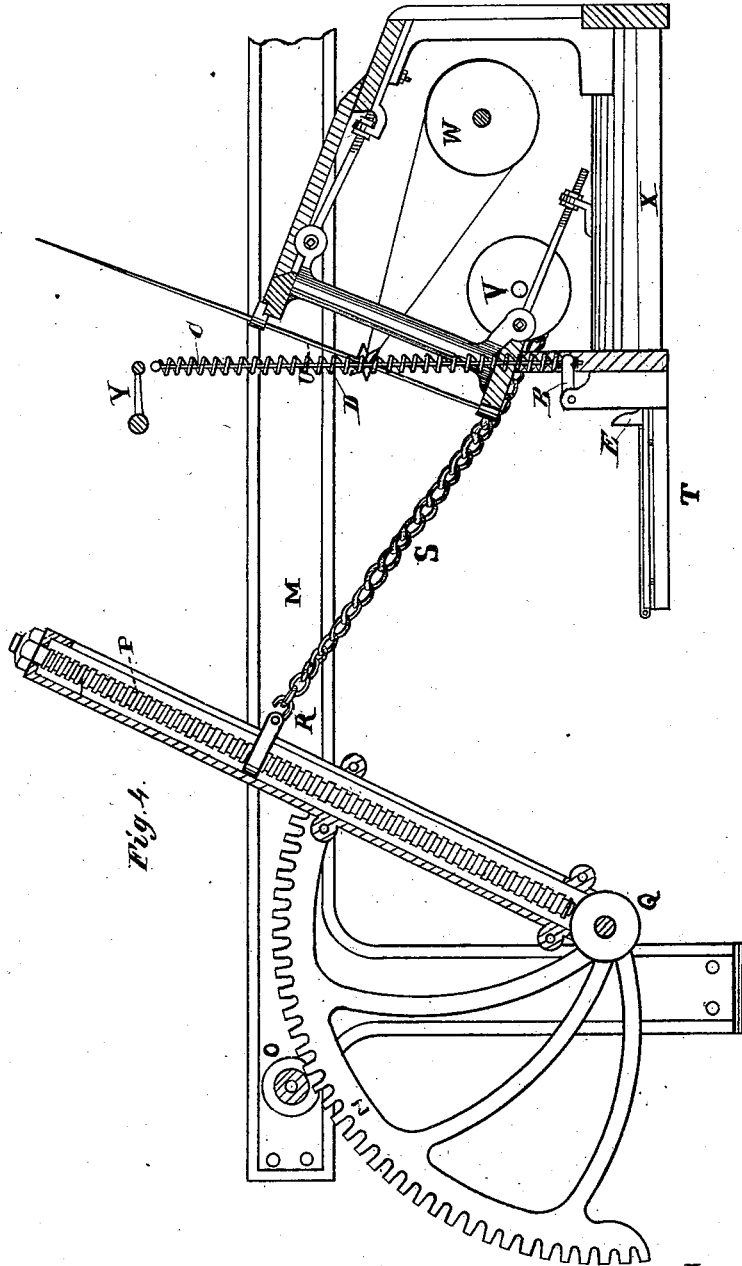

Fig. 1.

Witnesses;
G. H. Dunell
W. G. Harmon

Inventor;
David Jackson.
Per *Chas. Moore,*
Atty.

UNITED STATES PATENT OFFICE.

SAMUEL JACKSON, OF LAWRENCE, MASSACHUSETTS.

IMPROVEMENT IN YARN-WINDING REGULATORS OF SPINNING-MULES.

Specification forming part of Letters Patent No. 184,782, dated November 28, 1876; application filed February 24, 1876.

To all whom it may concern:

Be it known that I, SAMUEL JACKSON, of Lawrence, in the county of Essex and Commonwealth of Massachusetts, have invented a Yarn-Winding Regulator for Mules.

The object of my invention is to construct a yarn-winding regulator which shall be simple in its construction and effective for the purpose herein set forth. This I accomplish by a simple device, consisting of an elbow-lever and two inclined planes, so attached that the one will raise the other to engage a friction-wheel attached to a quadrant by means of a faller or carrier-wire, and depressed by the wheel pressing against a stud, after having performed its work of turning a screw; and I do declare that the following is such a full, clear, and exact description thereof that others skilled and familiar with the art to which it appertains can make and use the same, reference being had to the accompanying drawings, of which the first sheet represents, in Figures 1, 2, and 3, my improved regulator in detail; and the second sheet, Fig. 4, represents a portion of a mule, showing my regulator as attached thereto, and its workings.

A of the first sheet represents a bed, designed to support the working parts of the regulator; B, an elbow-crank designed to raise the plane I; C, a rod designed to engage with the faller-wire; D, a spiral spring, designed to allow the rod C to be depressed; E, an upward-projecting stud, designed to engage with the friction-wheel of a quadrant; F F, bolts or pins designed to hold the sliding piece G to the frame; G, a sliding piece; H, H, two inclines, designed to be raised by the inclines K K; I, a plane resting on the inclines H H, designed to engage with a friction-wheel; K K, two inclines, designed to raise the plane I; L L', pads designed to increase

friction; M, on the second sheet, a frame of a mule; N, a quadrant; O, gear-wheel; P, worm-screw; Q, friction-wheel; R, a nut; S, a chain; T, my improved regulator as attached to a mule; U, a spindle; V, a reverse-drum; W, a driving-drum; X, a carriage, and Y faller or carrier-wire.

As the mule is put in operation, with my regulator attached, and the yarn spun, the carriage X comes back, winding the yarn, pressing down on the faller or carrier-wire. As the yarn tightens, the faller-wire comes in contact with the rod C, forcing the elbow-crank B down, communicating motion to the slide G, which raises the plane I sufficiently to engage with the friction-wheel Q, when passing beneath the same, turning the wheel and screw a measured distance, raising the nut R, (as with all regulators,) which is connected with the winding-chain. When the raised plane I has passed under the wheel Q, turning the same, it comes in contact with the stud E, forcing the slide G back, and allowing the plane I to fall back in place, and pass with the carriage freely from beneath the friction-wheel.

Having thus described my said invention, I claim—

In a yarn-winding regulator, constructed as herein described, the combination of the frame A, the elbow-crank B, the perpendicular rod C, the spring D, the stud E, guide-bolts F F, the slide G, the inclines H H, the plane I, the inclines K K, and pads L L', each with each, in a manner and for the purpose substantially as set forth.

SAMUEL JACKSON. [L. s.]

Witnesses:

C. H. LITTLEFIELD,
CHS. D. MOORE.