

J. I. BENHAM & L. LEEDS.

HOISTING-MACHINES.

No. 184,820.

Patented Nov. 28, 1876.

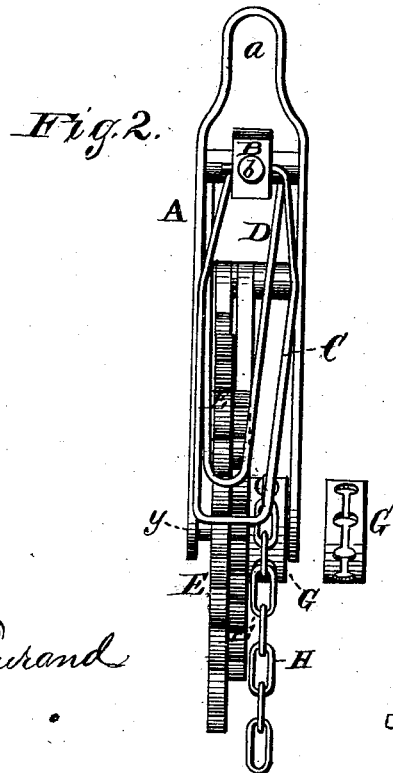
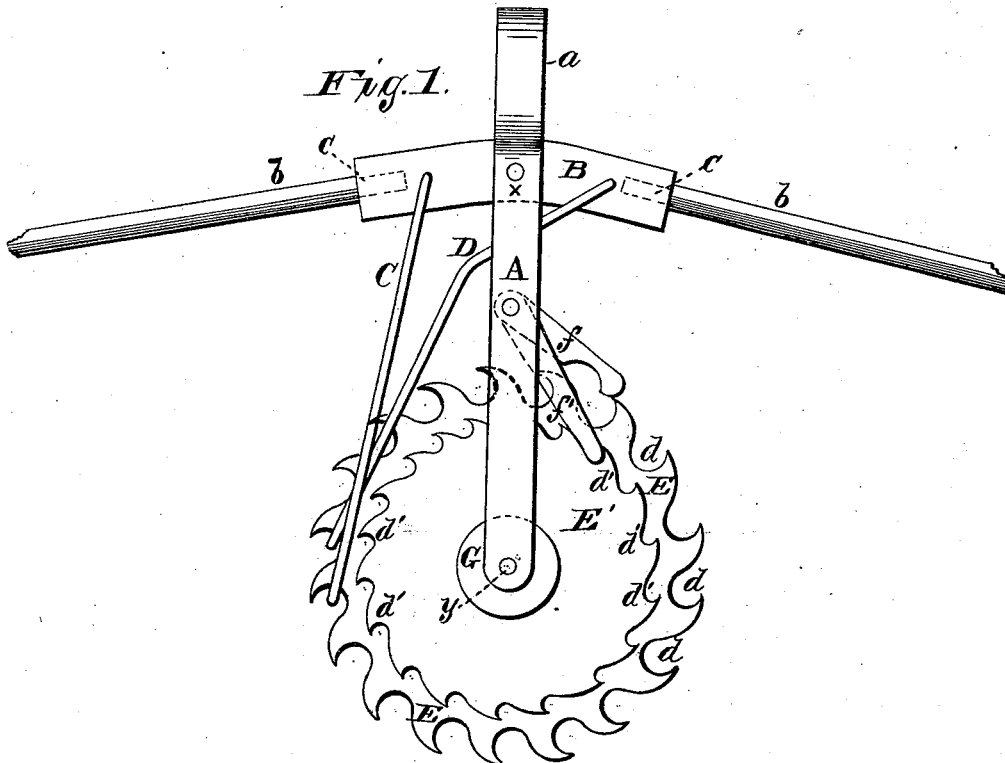

WITNESSES
Frank L. Ourand
C L Evert

INVENTOR
James S. Benham
Lodowick Leeds
Alexander Hudson
ATTORNEYS

UNITED STATES PATENT OFFICE.

JAMES I. BENHAM AND LODOWICK LEEDS, OF NEW LONDON, CONN.

IMPROVEMENT IN HOISTING-MACHINES.

Specification forming part of Letters Patent No. 184,820, dated November 28, 1876; application filed August 29, 1876.

To all whom it may concern:

Be it known that we, JAMES I. BENHAM and LODOWICK LEEDS, of New London, in the county of New London and in the State of Connecticut, have invented certain new and useful Improvements in Hoisting-Machines; and do hereby declare that the following is a full, clear, and exact description thereof, reference being had to the accompanying drawings, and to the letters of reference marked thereon, making a part of this specification.

The nature of our invention consists in the construction of a hoisting apparatus, as hereinafter more fully set forth.

In the accompanying drawings, which form a part of this specification, Figure 1 represents a side elevation, and Fig. 2 an end view, of the machine.

A represents a metallic stirrup or frame, having a contracted portion, *a*, at the top for attaching a hook or other device to suspend the machine to a ceiling, beam, or other place. Between the lower ends of the bars of the frame is journaled a shaft, *y*, and upon this shaft is placed a wheel, *E E'*, having a series of hooked notches, *d d*, on its periphery and a series of smaller and similar notches, *d' d'*, on one face, near the periphery. *G* represents a pulley, also mounted on the shaft *y* and rotated with the wheel. This pulley is provided with suitable notches or devices to prevent the chain *H*, which passes around the same, from slipping. *B* represents a metallic head, which is pivoted or journaled, at *x*, between the bars of the frame *A*, just below the contracted portion *a*. Each end of this head is socketed, as seen at *C C*, Fig. 1, and into said sockets are inserted operating handles or levers *b b*. These levers are easily detachable from the head, for replacing them in case of breakage, or for any purpose. Connected to the head are two pivoted bails or hooks, *C D*, one on each side of the pivot *X*, and both ex-

tending down to and on the same side of the wheel *E*, for engaging in the notches of the same. On a shaft, between the point *x* and the top of the wheel *E*, are pivoted two gravitating pawls, *f f'*. These pawls drop into the notches *d d'*, respectively, of the wheel on the side opposite to the bails *C D*.

The operation of the machine is simple. The frame being suspended, and the chain *H* being passed around the pulley *G*, the chain is attached to anything to be hoisted. The levers *b b* are raised and lowered alternately, so that the bails *C D* will catch, one after the other, in the notches *d* of the wheel, while the pawls *f f'* drop, one after the other, in the notches *d d'* in the same on the other side. This action will cause the wheel to have a continuous rotating motion, and thus raise the chain by the revolving of the pulley *G* with the wheel. The two pawls will prevent any backward movement, inasmuch as one is always in a notch of the wheel.

Having thus fully described our invention, what we claim, and desire to secure by Letters Patent, is—

The combination of the frame *A*, the wheel *E*, with hooked notches *d*, the wheel *E'*, of smaller diameter, on the face of the wheel *E*, and having hooked notches *d'* formed of the same shape and extending in circular form the same direction as the notches *d*, the gravitating pawls *f f'* pivoted to the stirrup *A*, the pivoted head *B*, having handles *b b*, and the bails or hooks *C D* pivoted to the head *B*, all constructed substantially as and for the purposes herein set forth.

In testimony that we claim the foregoing we have hereunto set our hands this 22d day of August, 1876.

JAMES I. BENHAM.
LODOWICK LEEDS.

Witnesses:

BENJ. M. CARROLL,
HENRY PHILLIPS.