

G. W. BRADLEY.

WRENCHES.

No. 184,827.

Patented Nov. 28, 1876.

Fig. 1.

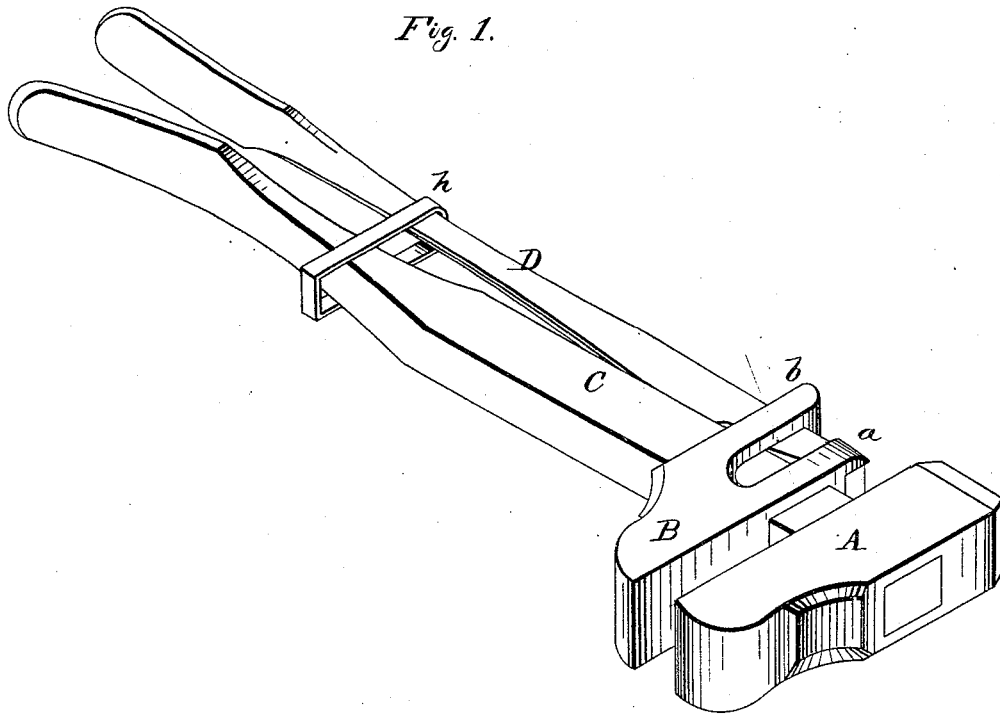
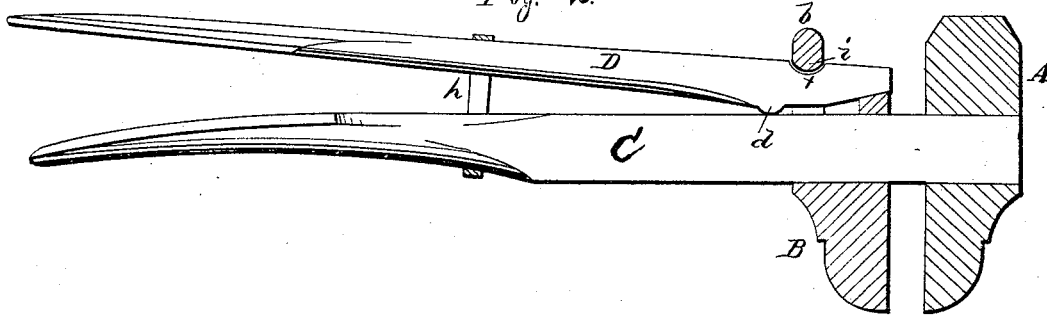

Fig. 2.



WITNESSES

*H. Aubrey, Soutman*  
*A. N. Miller*

INVENTOR

*Geo. W. Bradley*  
By *Alexander Mason*  
Attorneys

# UNITED STATES PATENT OFFICE.

GEORGE W. BRADLEY, OF BATTLE CREEK, MICHIGAN.

## IMPROVEMENT IN WRENCHES.

Specification forming part of Letters Patent No. 184,827, dated November 28, 1876; application filed May 13, 1876.

*To all whom it may concern:*

Be it known that I, GEORGE W. BRADLEY, of the city of Battle Creek, in the county of Calhoun, and in the State of Michigan, have invented certain new and useful Improvements in Wrenches; and do hereby declare that the following is a full, clear, and exact description thereof, reference being had to the accompanying drawing, and to the letters of reference marked thereon, making a part of this specification.

The nature of my invention consists in the construction and arrangement of a wrench, as will be hereinafter more fully set forth.

In order to enable others skilled in the art to which my invention appertains to make and use the same, I will now proceed to describe its construction and operation, referring to the annexed drawing, in which—

Figure 1 is a perspective view of my wrench. Fig. 2 is a side view of the same, partly in section.

A represents the stationary jaw with handle C, constructed in the usual manner for this class of wrenches. B is the movable jaw, made in the form of a sleeve to slide on the body of the handle C, and above said handle the movable jaw B forms a loop, *b*, at the rear, and two side projections, *a a*, at the front. D represents a lever, which serves as the other handle of the wrench. This lever is passed through the loop *b*, and its front end fitting between the projections *a a*, for the purpose of holding the adjustable jaw firmly to the work. The lever-handle D is provided with

a suitable fulcrum or projection, *d*, on its under side, and the loop *b*, into which the lever fits, is provided with another fulcrum, *i*, entering a notch or recess, *x*, on the handle. A loose link, *h*, sliding on the two handles, serves to hold the wrench in position when it is desired to firmly hold the jaws in one place or adjusted to a given position.

The operation is as follows: Grasping the wrench by the handled end C D, the jaws A B are adjusted the requisite distance apart for the work in hand. Now, by simply compressing or forcing the lever ends together by the natural muscular movement required in turning a nut with any wrench, the jaw B is very firmly and securely locked and held in place, while the work is being done, by means of the immense pressure and friction caused by the forcing of the fulcrum *d* of the lever-arm D on the wrench-arm C.

Having thus fully described my invention, what I claim as new, and desire to secure by Letters Patent, is—

The combination of the jaw A, with handle C, the movable jaw B, with loop *b*, having fulcrum *i*, and the lever D, with fulcrum *d*, substantially as and for the purposes herein set forth.

In testimony that I claim the foregoing I have hereunto set my hand and seal this 10th day of April, A. D. 1876.

GEORGE W. BRADLEY. [L. S.]

Witnesses:

F. W. CLAPP,  
F. M. WADLEIGH.