

J. FUNCK.
LAMP.

No. 184,855.

Patented Nov. 28, 1876.

3 Fig. 1.

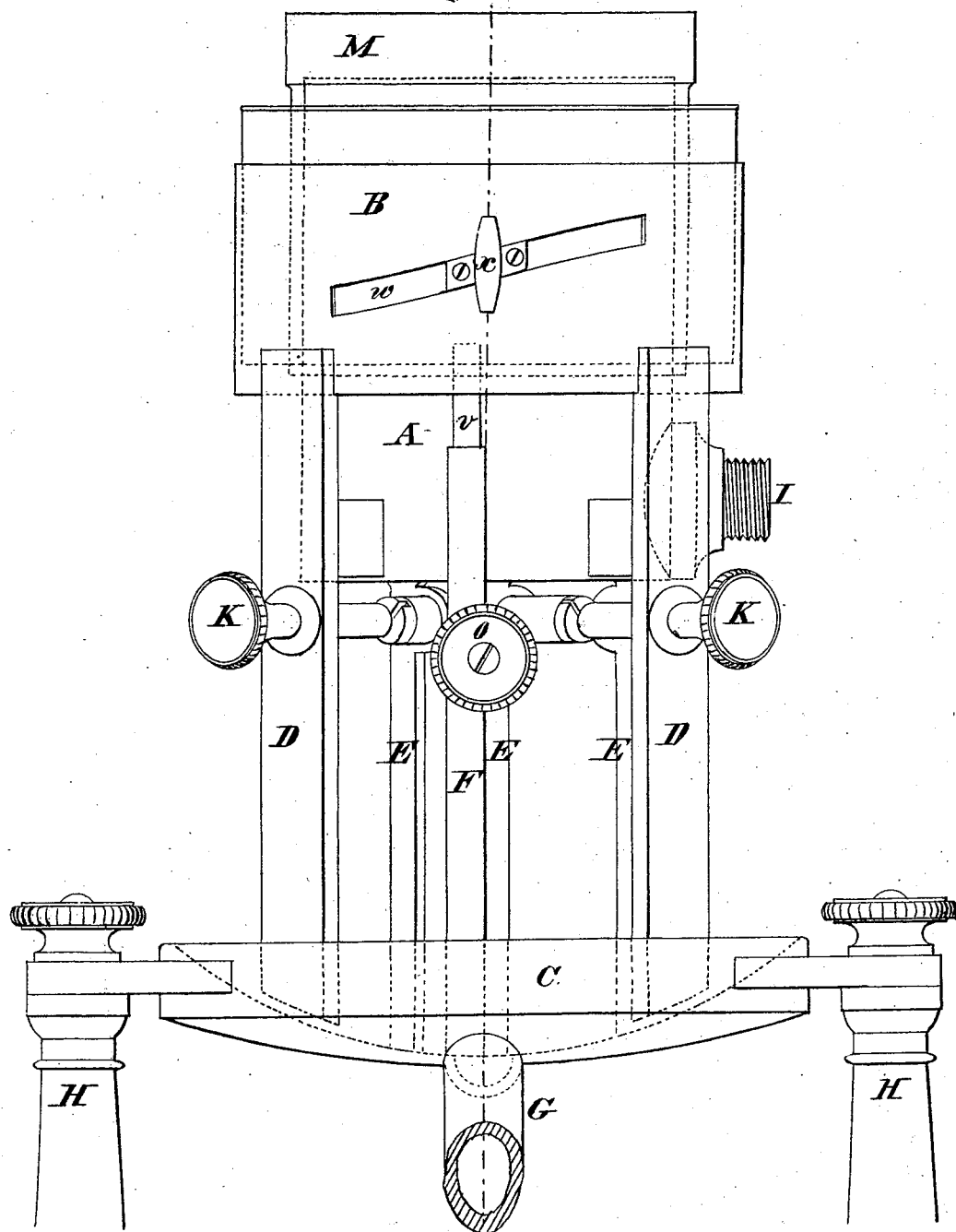

WITNESSES

Chas J. Coock
Walter Allen

INVENTOR

Joseph Funck
By *Knights* Attorneys

J. FUNCK.
LAMP.

No. 184,855.

Patented Nov. 28, 1876.

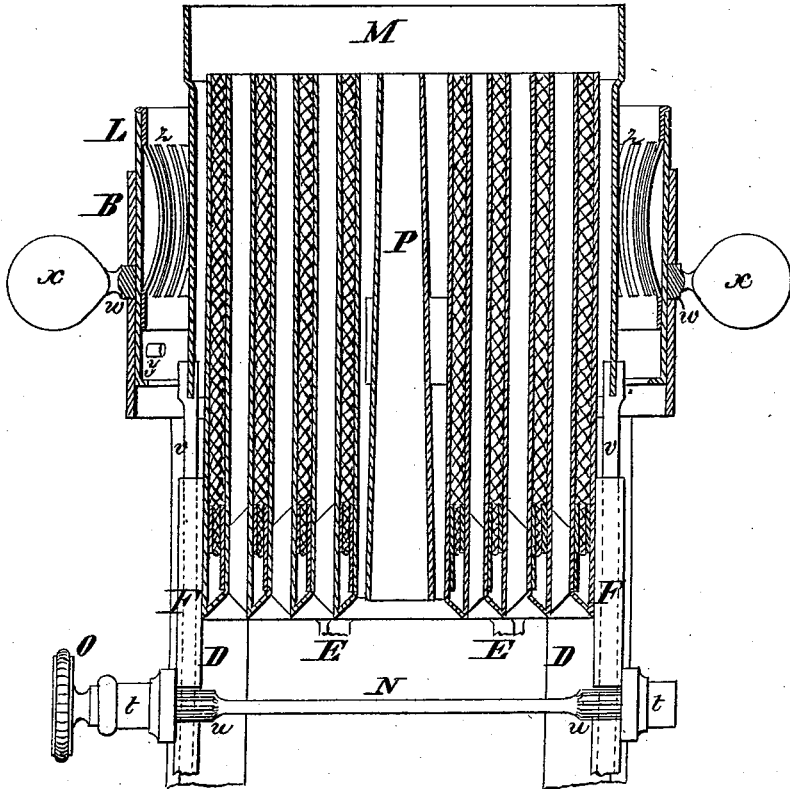
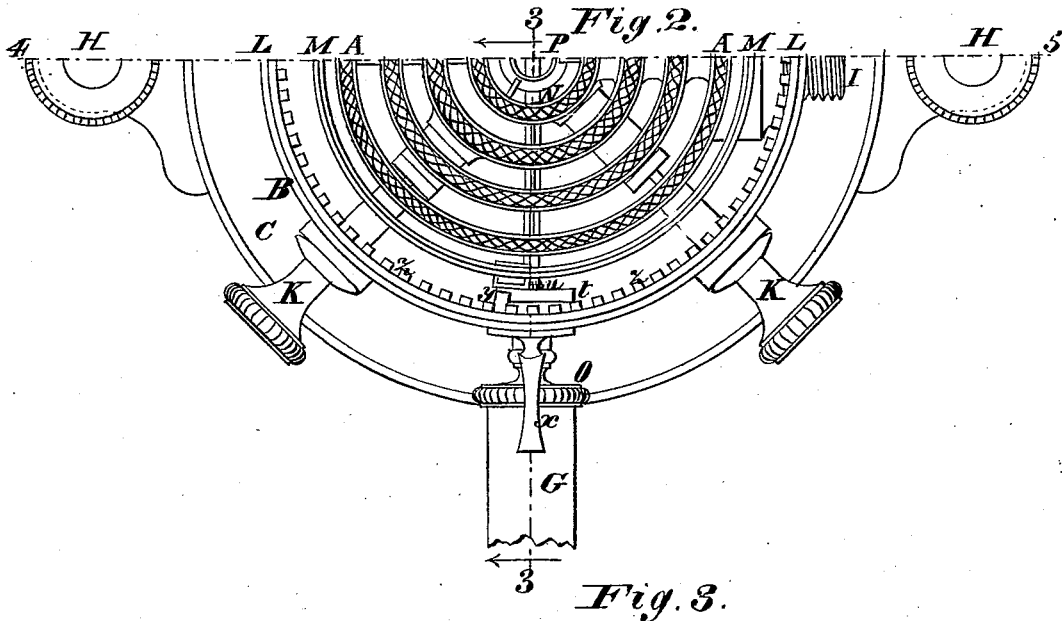

WITNESSES
Chas. J. Gooch
Walter Allen

INVENTOR
Joseph Funck
 BY *Knights* Attorneys

J. FUNCK.
LAMP.

No. 184,855.

Patented Nov. 28, 1876.

Fig. 4.

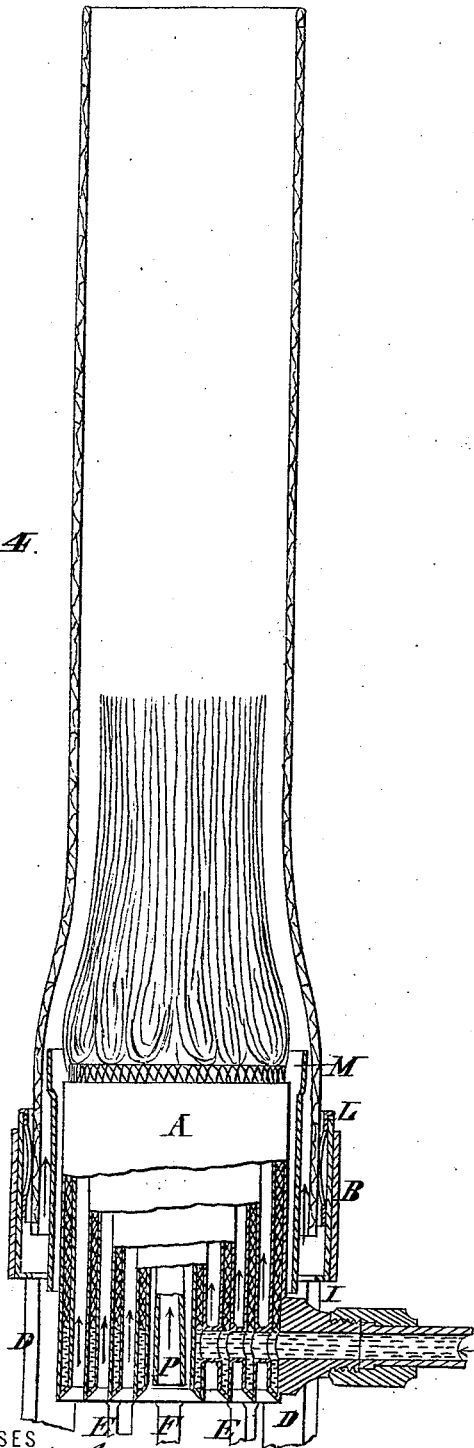

WITNESSES

Chas. Hoock
Walter Allen

Fig. 5.

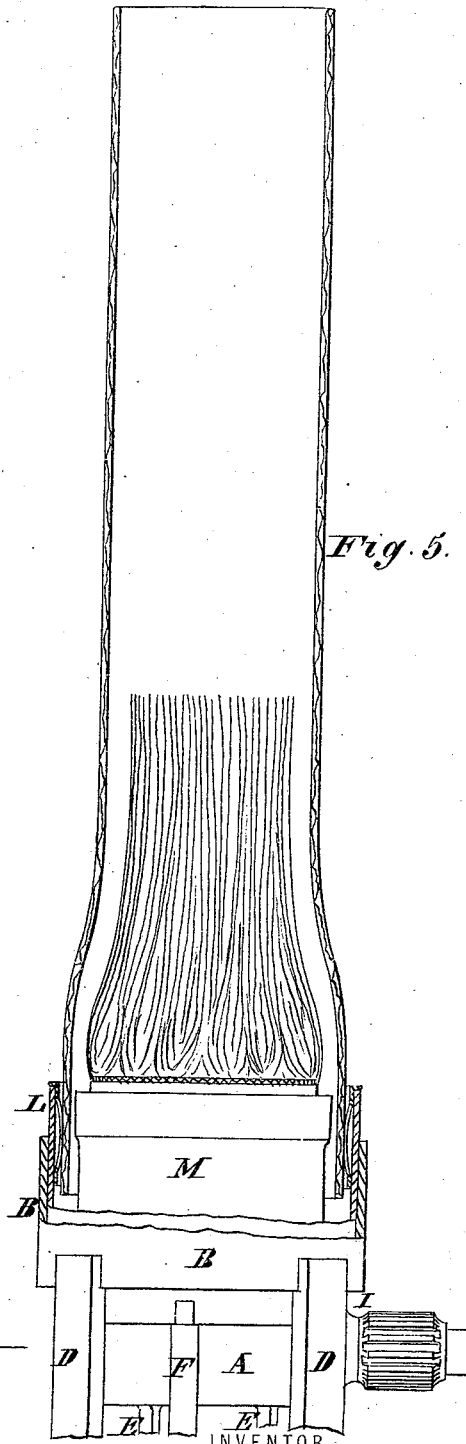

INVENTOR

Joseph Funck
By *Smith & Co.* Attorneys

UNITED STATES PATENT OFFICE.

JOSEPH FUNCK, OF TOMPKINSVILLE, NEW YORK.

IMPROVEMENT IN LAMPS.

Specification forming part of Letters Patent No. 184,855, dated November 28, 1876; application filed October 19, 1876.

To all whom it may concern:

Be it known that I, JOSEPH FUNCK, of Tompkinsville, Staten Island, in the county of Richmond and State of New York, have invented a new and useful Improvement in Burners for Light-House Lamps, of which the following is a specification:

The improved burner which is the subject-matter of this invention is designed for use in light-houses, as a burner of the first order, having four concentric wicks; but the features of novelty hereinafter set forth, or either of them, may be applied to burners of smaller capacity.

The first part of the invention relates to means for elevating the chimney when the wicks are first lighted, to keep the same from being heated too rapidly, and for lowering the chimney to give a proper shape to the flame; and the provision for this purpose consists of a sliding chimney-holder, actuated independently of the other movable parts of the burner.

The object of the second part of the invention is to provide in the most simple and effective way for burning different kinds of oil, and for regulating the draft according to the temperature and wind, so as to insure the proper supply of oxygen to the outside of the flame independently of the adjustment of the chimney; and this part of the invention consists in a movable air-jacket, the upper end of which is, by preference, slightly enlarged, the same being located in the air-space between the outer wick-tube and the chimney-holder, and adapted to be raised or lowered independently at will, to regulate the application of air to the outside of the flame, as required.

The third part of the invention consists in the employment of an upwardly-tapering air-tube at the center of the burner, in lieu of the ordinary button or other deflector.

The effects of this device are a more powerful flame, having a central opening of uniform, or nearly uniform, width, and an abundant supply of oxygen to the expanded upper end of the flame, as well as to its lower part, the latter being supplied by the air admitted around the air-tube and between the several wick-tubes.

Figure 1 is a front elevation of the improved four-wick burner hereinbefore referred to. Fig.

2 is a half-plan or top view of the same. Fig. 3 represents a vertical section of the upper part thereof on the line 3 3, Figs. 1 and 2. Figs. 4 and 5 are front views of the upper part of said burner on a smaller scale, and partly in section on the line 4 5, Fig. 2, illustrating the operation of the burner.

Like letters of reference indicate corresponding parts in the several figures.

This improved burner has its wick-tubes A supported within a concentric cylindrical ring, B, and above a horizontal basin, C, by four uprights, D, which also support said ring, and are connected to the outer wick-tube by radial arms projecting from the latter at its lower end. The tubes are in like manner supported within each other, and guide-tubes E F, depending from the several wick-tubes, form additional connections and supports. The primary object of the basin C is to collect the overflow of oil, which is conveyed to a receptacle by a pipe, G, leading therefrom. It also constitutes the base of the burner, as above appears, and is itself supported on a pair of pillars, H, or equivalent supports, being provided with laterally-projecting lugs to rest thereon and receive retaining-nuts, as represented in Figs. 1 and 2. The oil is supplied to the several wick-spaces through a neck, I, attached to the outer tube, and through tubular connections in line therewith, and each space contains the ring or rings of an independent wick-elevator. The racks and pinions pertaining to the latter are inclosed in the guide-tubes E, and housings attached thereto, and the pinions are operated by rotary knobs K, four in number, supported by the respective uprights D in regular order, beginning in front of the neck I with the knob which actuates the middle wick.

The space within the ring B around the wick-tubes accommodates a chimney-holder, L, fitted to turn and slide within said ring, and a concentric inner jacket, M. The chimney-holder has an elastic lining, *z*, of sheet metal, slotted and bowed, so as to bear on the outside of the chimney, and three equidistant inwardly-projecting studs, *y*, on which the lower end of the chimney rests. It is supported within the ring B by a pair of thumb-lugs, *x*, attached thereto at front and rear

within inclined slots *w*, which convert a partial rotation of the holder, readily imparted by means of the lugs, into an upward or downward movement of the same. The chimney is thus independently elevated to keep it from being too rapidly heated when the wicks are lighted, and in like manner lowered to regulate the shape of the flame. The air-space within the base of the chimney is of about double the width of the air-space between two of the wick-tubes. This space is divided by the inner jacket M, so that a portion of the air for the outside of the flame shall be heated by direct contact with the outer wick-tube, and pass to the flame at its base, while the remainder serves to absorb heat from the chimney and to feed the upper part of the flame. There is an ample passage for air outside of the jacket M, as well as within it. The upper end of the jacket has been expanded and made slightly flaring, as shown, to broaden the base of the flame. The jacket M is supported by a pair of vertical racks, *v*, similar to those of the wick-elevators, and these slide in the guide-tubes F, and are meshed by pinions *u* on a single shaft, N, and receive motion therethrough from a rotary knob, O, attached to the front end of said shaft. Housings *t*, substantially similar to those of the wick-elevators, are attached to the guide-tubes F, to support the respective ends of the shaft N. Provision is thus made for raising and lowering the jacket M independently of the chimney-holder and of the other parts of the burner. The elevation of the jacket, as illustrated in Figs. 1, 3, and 4, forms a circumferential wall around the base of the flame to confine the heat and promote combustion. The jacket is thus utilized in burning heavy oil, when the wicks have to be unusually elevated, as represented in Fig. 4, to give escape to the oil, and a more intense heat is required to reduce the carbonaceous particles to an incandescent state, so as to produce the requisite white flame. The jacket may be elevated, to a greater or less extent, as required, and at the same time the chimney may be in its lowest or highest position, or in any position intermediate thereto, as circumstances may demand. In Fig. 5 the jacket M is shown in its lowest position, and the chimney-holder L in its highest, as when starting the light.

The central air-space within the inner wick-tube is divided by an axial air-tube, P, extending nearly the entire depth of the wick-tubes, and supported by wings, so as to leave

an unobstructed air-space around it. This air-tube is not cylindrical, but tapers upwardly, so as to discharge a condensed volume of air upwardly through the center of the flame, while that around it, more highly heated than it would otherwise be, feeds the base of the flame. Besides this effect, experiments have demonstrated that the tapering form of the air-tube causes the expansion of the upper end of the flame, so that the flame of the improved burner has a central opening of uniform or nearly uniform diameter from bottom to top, and is correspondingly increased in power.

The described mechanism for adjusting the jacket M is preferred; but mechanical equivalents thereof, as of other details, may obviously be substituted, if preferred.

I am aware that a four-wick burner has been made with an adjustable external deflector surrounding the wick-tubes, the upper end of said deflector being curved inwardly to deflect air against the flame, while a support or gallery for the chimney is attached to its outer surface. The chimney and said deflector are thus raised and lowered simultaneously, and the ordinary button is employed in combination therewith. This device I disclaim as old.

The following is what I claim as new, and desire to secure by Letters Patent, namely:

1. The combination of the stationary ring B, having inclined slots *w*, and the chimney-holder L, supported within said ring by outwardly-projecting thumb-lugs *x* working in said slots, substantially as herein shown and described, an unobstructed annular air-inlet being formed within the chimney-holder, while provision is made for raising and lowering the chimney at will, independently of the other movable parts of the burner.

2. The concentric jacket M, surrounding the wick-tubes within the chimney-holder, and adjustable vertically independently of the chimney-holder and other parts of the burner, substantially as herein specified, for the purposes set forth.

3. In combination with one or more annular wick-tubes, A, the upwardly-tapering air-tube P, arranged axially in the central air-space, and serving to divide the same, substantially as herein represented and described, for the purposes specified.

JOSEPH FUNCK.

Witnesses:

JAS. L. EWIN,
ABNER C. THOMAS.