

R. S. NORTON.  
MACHINE FOR TURNING THE EDGES OF COLLAR-BANDS, &c.  
No. 184,891. Patented Nov. 28, 1876.

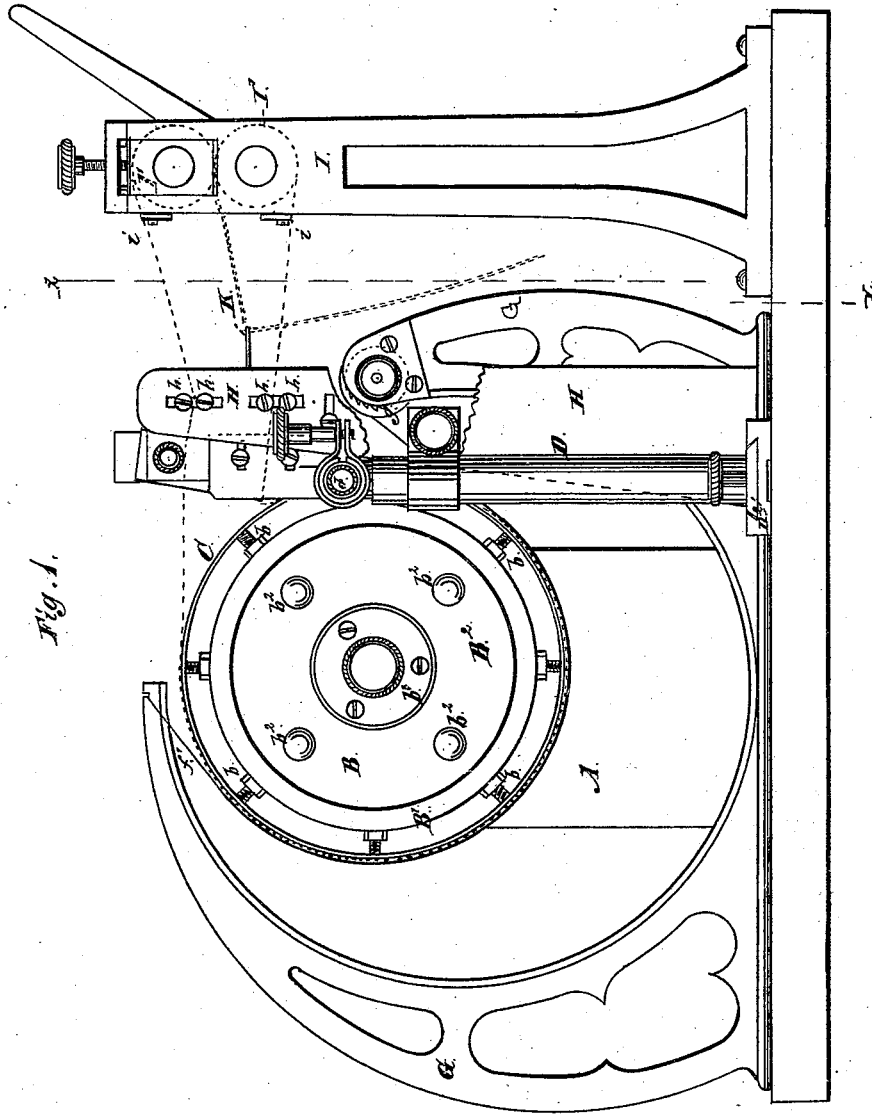

Fig. 1.

Witnesses:  
L. M. Harris  
Herwick F. Briggs.

Rowland S. Norton,  
Inventor.

By Coburn & Thacher

Attys.

R. S. NORTON.

MACHINE FOR TURNING THE EDGES OF COLLAR-BANDS, &c.  
No. 184,891. Patented Nov. 28, 1876.

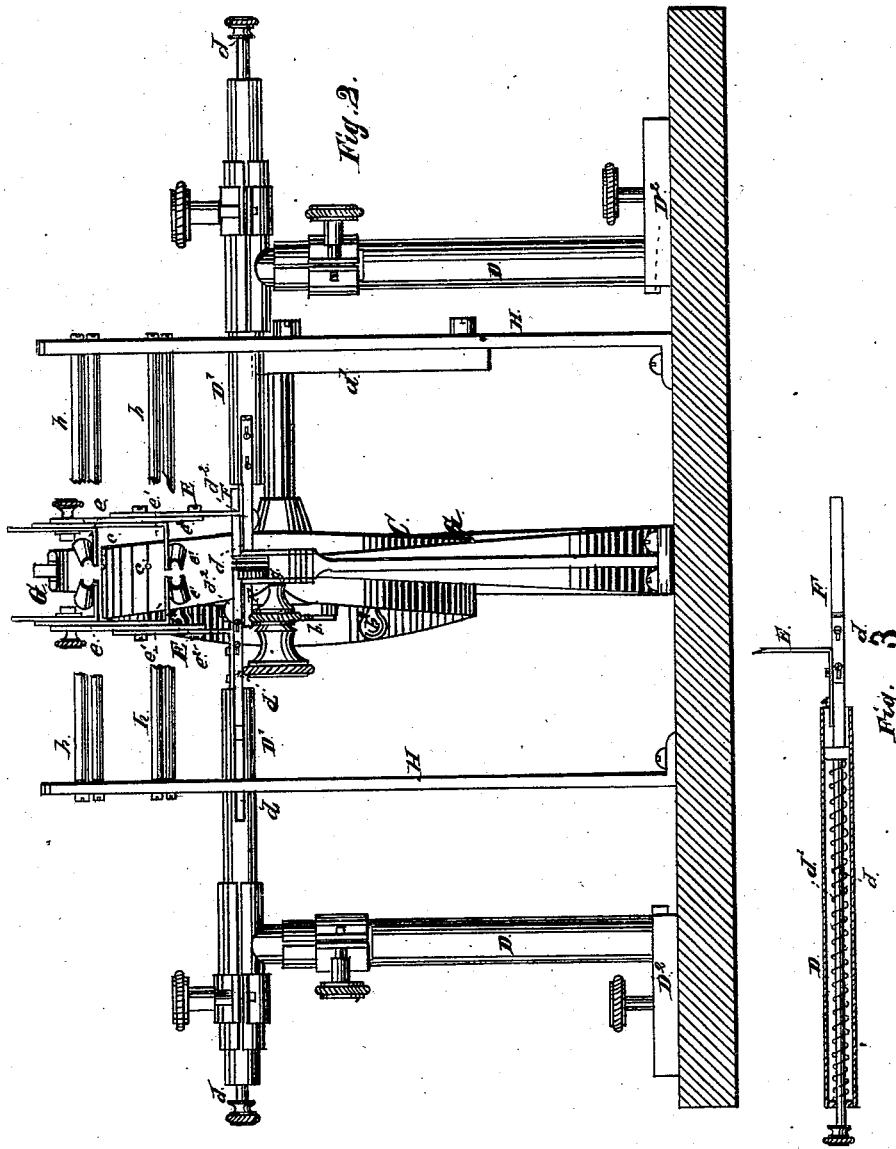

Witnesses:  
L. M. Harris,  
Hennrich L. Gross.

Rowland S. Norton,  
Inventor.  
By Coburn & Thacher  
Attys.

R. S. NORTON.  
MACHINE FOR TURNING THE EDGES OF COLLAR-BANDS, &c.  
No. 184,891. Patented Nov. 28, 1876.

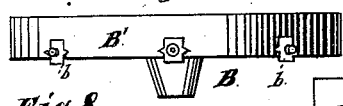
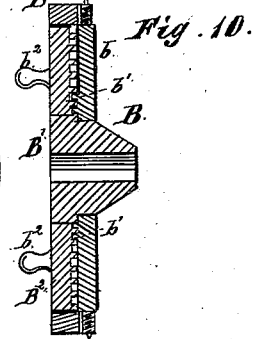
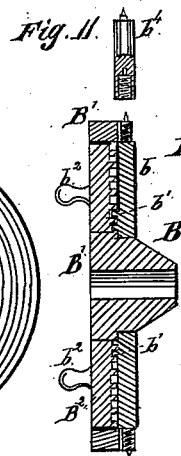
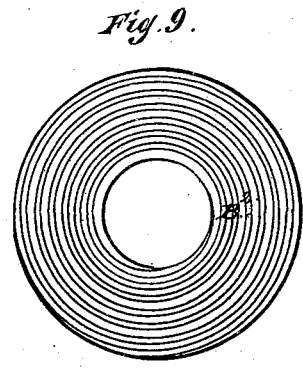
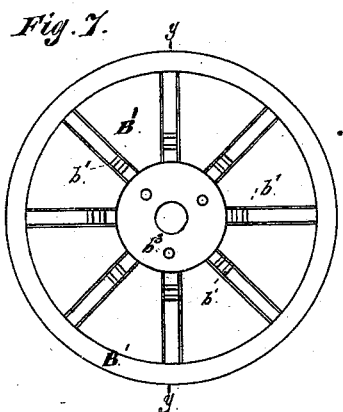
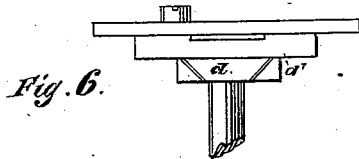
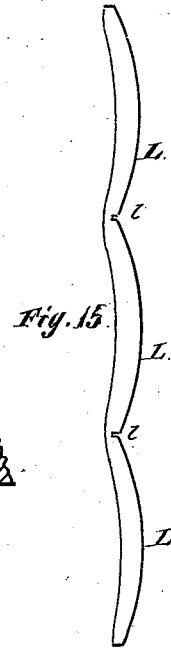
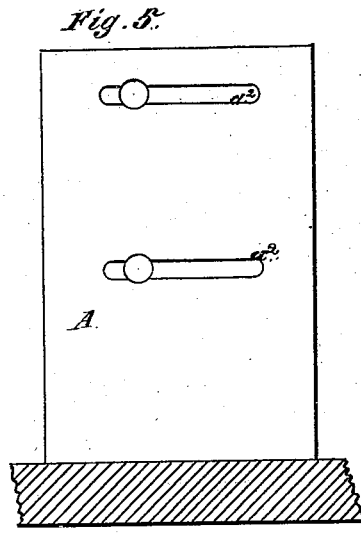
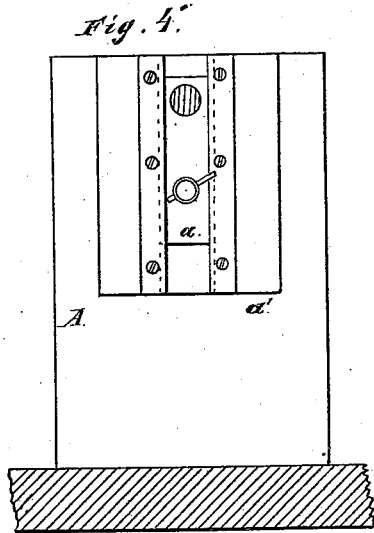

Witnesses: *Fig. 12.*  
L. M. Harris  
Heinrich F. Bruns, Jr.

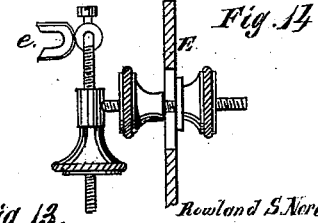
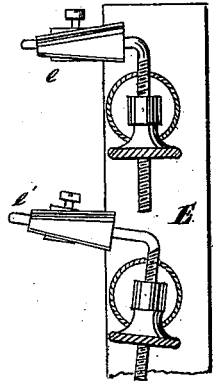

*Fig. 13.*  
Rowland S. Norton,  
Inventor.  
By *Leoburn & Pracher*  
Atty.

# UNITED STATES PATENT OFFICE.

ROWLAND S. NORTON, OF CHICAGO, ILLINOIS.

IMPROVEMENT IN MACHINES FOR TURNING THE EDGES OF COLLAR-BANDS, &c.

Specification forming part of Letters Patent No. **184,891**, dated November 28, 1876; application filed March 6, 1876.

*To all whom it may concern:*

Be it known that I, ROWLAND S. NORTON, of Chicago, county of Cook and State of Illinois, have invented a new and useful Improvement in Machines for Turning the Edges of Collar-Bands and other articles of varying width, which is fully described in the following specification, reference being had to the accompanying drawings, in which—

Figure 1 represents a side elevation of my machine; Fig. 2, a sectional view, taken on the line *x x*, Fig. 1; Fig. 3, a sectional view of one of the tubular arms which carry the folding-guides; Figs. 4, 5, and 6, detail views of the standard and adjustable plates, upon which the pattern-wheel is mounted; Figs. 7 and 8, plan and edge views of one disk of the pattern-wheel; Fig. 9, a plan view of the inner face of the adjusting-disk of said wheel; Fig. 10, a sectional view of the wheel, taken on the line *y y*, Fig. 7. Fig. 11 represents a device to be attached to the wheel, to adapt it to large patterns; Figs. 12, 13, and 14, views of the adjustable devices upon which the folding-guides are mounted; and Fig. 15 represents a strip of collar-bands as prepared for the machine.

The object of my invention is to provide a machine upon which the edges of collars, collar-bands, cuffs, and other like articles may be turned and folded, ready for stitching upon a sewing-machine.

The invention consists in a circular pattern plate or cam, corresponding in size to the article before turning, and mounted upon an adjustable wheel, with which it turns, around which a prepared strip of articles passes to turning-guides which are mounted upon sliding arms controlled in their position by the pattern-cam, against the edges of which they press. It also consists in various subordinate devices and attachments, all of which will be hereinafter more fully described.

In the drawings, A represents a standard, upon which is mounted a pattern-wheel, B. The journal-shaft of the wheel is attached to a plate, *a*, which is adjustable vertically in dovetailed grooves upon a second plate, *a*<sup>1</sup>, which, in turn, is adjustable horizontally upon the standard A by means of horizontal slots *a*<sup>2</sup> in the latter, and set-screws passing

through the slots into the plate *a*<sup>1</sup>. The wheel B is constructed with two disks, B<sup>1</sup> and B<sup>2</sup>, the former being provided with a hub and a flanged rim, within which the latter is received, being also fitted about the hub. A series of sliding arms, *b*, are fitted in radial grooves in the disk B<sup>1</sup>, which are provided with a series of teeth or projections, *b*<sup>1</sup>, upon their inner sides, and with wedge-shaped flanges on their edges, which fit in corresponding guideways in the sides of the slots. They also carry points upon their upper ends, which project through the rim of the wheel, and upon the same ends screw-threads are cut. This inner face of the disk B<sup>2</sup> has a spiral groove cut upon it, as shown in Fig. 9 of the drawings, into which the teeth on the slides *b* are fitted when the two disks are brought together. The disk B<sup>2</sup> is movable independently about the hub of the disk B<sup>1</sup>, and by its rotation the slides are adjusted back and forth in the radial grooves of the disk B<sup>1</sup>. The disk B<sup>2</sup> is provided with one or more pins, *b*<sup>2</sup>, to assist in turning it around, and it is fastened to the disk B<sup>1</sup> by a circular plate, *b*<sup>3</sup>, which is screwed to the hub of the other disk.

A metallic circular pattern-plate, C, is mounted upon the wheel B by means of a series of holes, *c*, in it, into which the points on the ends of the slides *b* are caused to enter, and through which they project. This pattern is made of the exact size and shape of the collar-band or other articles before the edges are turned, and by means of the sliding arms *b* patterns of different sizes may be fitted to the wheel. For the purpose of accommodating very large sizes a short supplementary arm, *b*<sup>4</sup>, (shown in Fig. 11,) with a point at one end, may be screwed to the upper ends of the slides *b*, so as to extend their range of adjustment. Two standards, D, are placed upon opposite sides, and just in front of the wheel B, and upon them are mounted tubular arms D<sup>1</sup>, which inclose sliding rods *d*, which are forced inward toward the wheel by means of a coiled spring, *d*<sup>1</sup>, and are provided with small rollers *d*<sup>2</sup> at their inner ends. The standards D are attached to plates D<sup>2</sup>, which slide in dovetailed grooves in other plates to adjust the distance between the standards. A short standard, E, is also mounted upon the inner end of each

of these sliding rods, to each of which is attached a pair of folding or turning guides,  $e e$  and  $e' e'$ . These guides are in the form of curved plates, the concave surfaces of each pair being arranged opposite each other, and are placed in an inclined position, so that the ends farthest from the pattern will be nearer each other than their opposites. These guides are fixed to independent plates or wires, which are adjustably attached to other plates  $e^2$ , which are also adjustably attached to the standards E. By these devices the guides may be adjusted both vertically and horizontally, so as to be brought into any desired position; but the adjustment may be effected by any other devices suitable for this purpose. By adjusting the journal-shaft on which the wheel and pattern-plate are mounted the latter is arranged so that its edges will pass between the rollers on the ends of the sliding rods  $d$ , and as the pattern is rotated with the wheel C the rollers follow the contour of its two edges, and thus the opening between the turning-guides always corresponds to the width of the pattern-plate immediately below them, but at the point of egress must be the same as the width of the turned article. A forked guide, F, is attached to the inner end of each of the sliding rods  $d$  by means of slots in the guides and set-screws  $f$ , so that they may be adjusted. A strip of articles cut to the pattern desired is fed through each of the guides F to the pattern-plate C, passing around underneath the latter. These strips are arranged to conform exactly to the pattern-plate at one or both edges, and are held in place thereon by means of wires  $f^1$ , one end of which is attached to the upper end of a circular frame, G, within which the pattern wheel and plate are located. The wire passes around underneath the pattern-plate, and is attached to a tension device,  $g$ , on the other end of the frame G, by means of which it is tightened about the pattern-plate sufficiently to keep the strip in place thereon. Two standards, H, are placed just in front of the tubular arms  $D^1$ , in which are mounted two pairs of round bars,  $h$ , which are adjustable in slots in standards, so as to accommodate different thicknesses of the stuff to be folded. Still another set of standards, I, is placed in front of the standards H, in which is mounted a pair of rollers, I', the upper one being provided with adjustable journal-bearings, and the lower one with a crank. Two straight guiding and folding bars,  $i$ , are also attached to the standards I, and are adjustable thereon by means of slots and set-screws. A bent wire support, K, is attached to one of the standards H, for the purpose of guiding the folded strips away from the rollers.

The stuff to be folded is cut by patterns in long continuous strips of the different articles, such as collar-bands, collar-tops, cuffs, &c., joined together, as shown in Fig. 15 of the drawings, which represents a strip of collar-bands, L, prepared in this way for folding.

Wherever there are re-entering angles in such strips, as at  $l$ , Fig. 15, it is necessary to slit the strip, as shown in the drawing, to insure the satisfactory folding of the cloth at these points by the turning-guides.

The operation of the machine is as follows: The strips, prepared as described, are placed in the guides F, and carried underneath and around the pattern-plate, being arranged thereon, so as to exactly fit it, and held in place by the surrounding wire and points on the ends of arms  $b$ . When the strips are brought round to the front again, upon the upper side of the pattern-plate, they are separated, the upper one being carried through the upper pair of turning-guides, and the other one through the lower pair. Thence the two strips are passed respectively through the upper and lower sets of round bars  $h$ , and are conducted to the rollers I', the upper strip passing over the upper bar  $i$ , and over the upper roller, while the lower strip is carried underneath the lower bar  $i$  and under the lower roller. After passing around the rollers, as described, the two strips are brought together in front of the rollers and passed between them, the rollers being adjusted so that, when rotated by means of the crank attached to the lower one in the direction indicated by the arrows in Fig. 1 of the drawings, the two strips will be drawn through them together. This action of the rollers causes the proper feeding of the strips to the turning-guides, and the rotation of the wheel and pattern-plate, by means of which the position of the turning-guides is regulated. As the strips pass through the turning-guides the edges are turned over, and as they pass immediately between the round bars  $h$  the folds are pressed down, which operation is continued as the strips are drawn tightly over the straight edges of the bars  $i$ , and completed by passing around and through the pressure-rollers. The folded strips are brought to one side and held in the guide K, so as not to interfere with the passage of the strips from the bars  $h$  to the rollers. The course of the strips in the operation described above is indicated by the dotted lines in Fig. 1 of the drawings.

Having thus described my invention, what I claim as new, and desire to secure by Letters Patent, is—

1. In a machine for turning collar-bands and other like articles, a pattern-cam, C, of the size and form of the article to be turned, substantially as and for the purpose set forth.

2. The combination of the pattern-cam C, having a series of holes therein, and radial arms  $b$ , provided with points at their outer ends which project through the holes in the pattern-plate to hold the fabric in place, substantially as described.

3. The combination of the adjustable radial arms  $b$ , supplementary pointed pieces  $b^1$  and pattern-cam C, substantially as and for the purpose set forth.

4. The combination of sliding rods D and adjustable folding or turning guides mounted

thereon, substantially as and for the purpose set forth.

5. The combination of a pattern-cam, having the size and form of the article to be turned, and yielding turning guides or plates, the movement of which is controlled by the movement of the pattern-cam, substantially as and for the purpose set forth.

6. The combination of the revolving pattern-cam, sliding rods held in contact with the pattern-cam by yielding mechanism, and turning-guides mounted on said rods, substantially as and for the purpose set forth.

7. The combination of the yielding turning-guides, fold-compressing rods *h*, and suitable mechanism for pulling the strips of fabric through the machine, substantially as described.

8. The combination of the yielding turning-guides, folding-bars *i*, and suitable mechanism for pulling the strips of fabric through the machine, substantially as described.

9. The combination of the yielding turning-guides and the rollers *I'*, substantially as described.

10. The combination of the yielding turning-

guides, compressing-rods *h*, folding-bars *i*, and suitable mechanism for pulling the strips of fabric through the machine, substantially as described.

11. The combination of the revolving pattern-cam, yielding turning-guides, and elastic rollers *I'*, with suitable folding-bars between the guides and rollers, substantially as described.

12. The combination of the guides *F*, for directing the strips to the pattern-cam, turning-guides *e*, and pattern-cam *C*, substantially as described.

13. The combination of the revolving pattern-cam *C* and adjustable holding-wire *f'*, substantially as and for the purpose set forth.

14. The strips prepared for turning on the machine, consisting of a series of collar-bands, *L*, or other similar articles of varying width, connected together, and having a transverse cut at the re-entering angles, substantially as described.

ROWLAND S. NORTON.

Witnesses:

L. A. BUNTING,  
HEINRICH F. BRUNS.