

J. W. ODANIEL.  
WAGON-COUPLING.

No. 184,892.

Patented Nov. 28, 1876.

Fig. 1.

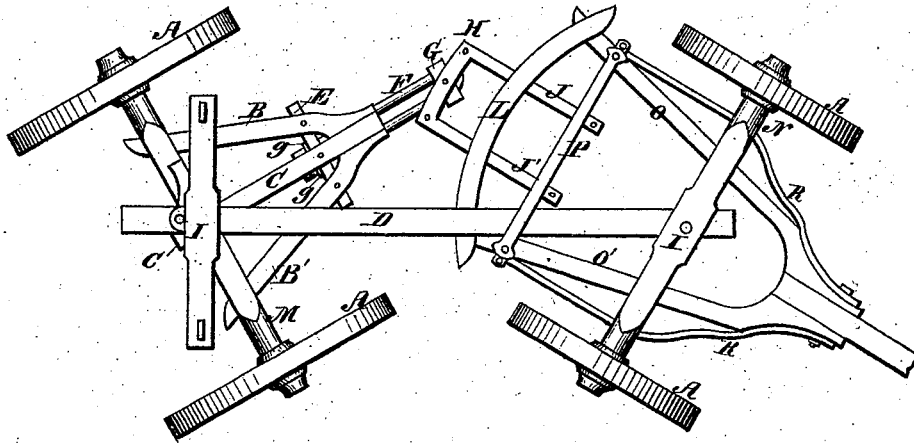

Fig. 2.

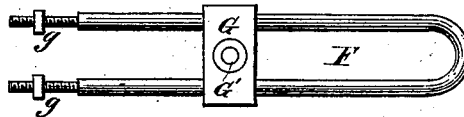
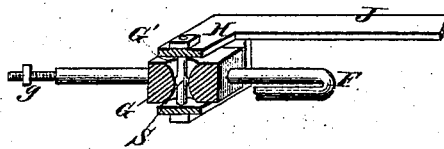

Fig. 3.



Witnesses.

M. C. Brown.  
S. M. Odaniel.

Inventor

John W. Odaniel.

# UNITED STATES PATENT OFFICE

JOHN W. ODANIEL, OF CLOVERDALE, INDIANA.

## IMPROVEMENT IN WAGON-COUPPLINGS.

Specification forming part of Letters Patent No. 184,892, dated November 28, 1876; application filed June 19, 1876.

*To all whom it may concern:*

Be it known that I, JOHN W. ODANIEL, of Cloverdale, in the county of Putnam and State of Indiana, have invented a new and useful Improvement in Wagon-Couplings, of which the following is a specification:

Figure 1 is a plan view of the wagon to which my improvement has been applied. Fig. 2 is a top view of the joint-connection enlarged. Fig. 3 is a detail section of the pivoted vibrating connection or coupling enlarged.

Similar letters of reference indicate corresponding parts.

The invention will first be fully described, and then pointed out in the claim.

A, wheels; B, hind hounds; C, king-brace of hounds extending to the rear of axle; M, rear axle; N, front axle of a wagon while on a turn; *g g*, nuts to fasten bars F to E. The joint connection or coupling by which the front and hind gears are coupled, so that both may oscillate in turning around curves, as indicated in Fig. 1, consists of a pivoted oscillating slider, G, pivoted to the rear bar J of the front gear, as shown in Fig. 3, and formed with two holes, so as to slide freely on the double bars F, which are attached to and under the front end of the hind hounds B. The bars F extend in front of the hounds B, and pass through the slider G, allowing it to slide and oscillate in any direction, as the distance between centers I of the reach D varies when turning around curves. The bars F are held in place by passing through the iron support

on front end of the rear hounds, and the cross-support E, which are secured to the hound B, and also serves for a support for a brake. The bar J is secured to the front gear by passing through irons on the sway-bar L, and the front ends attached to a bar made fast to the lower side of the front hounds O, directly beneath the upper sway-bar P. The connection between the hounds O and the forward axle N is strengthened by the brace-straps R. Between the sliding holes in the slider G, and at right angles, is formed a beveled hole, G', for the pivot H to work in, as indicated at Fig. 3. Said pivot is formed with an enlarged ball-like center, S, which allows slider G to oscillate in any direction. Both ends of the pivot H are secured to the front bar J. The bars F and J are adjustable for an extension of coupling, and can be taken off when desired to use as an old-style wagon.

Having thus described my invention, I claim as new, and desire to secure by Letters Patent—

In a wagon-coupling, the adjustable bar F, having the perforated oscillating slider G and the pivot-bolt H, formed with an enlarged center, as shown, in combination with the bar J attached to the front hounds, all constructed substantially as and for the purpose set forth.

JOHN W. ODANIEL.

Witnesses:

M. E. BROWN,  
S. M. ODANIEL.