

E. L. PERKINS.

MACHINERY FOR MANUFACTURING PASTE-BOARD.

No. 184,896.

Patented Nov. 28, 1876.

Fig. 1.

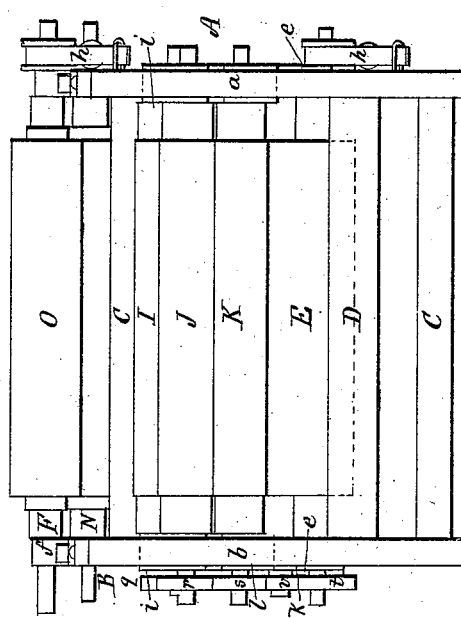
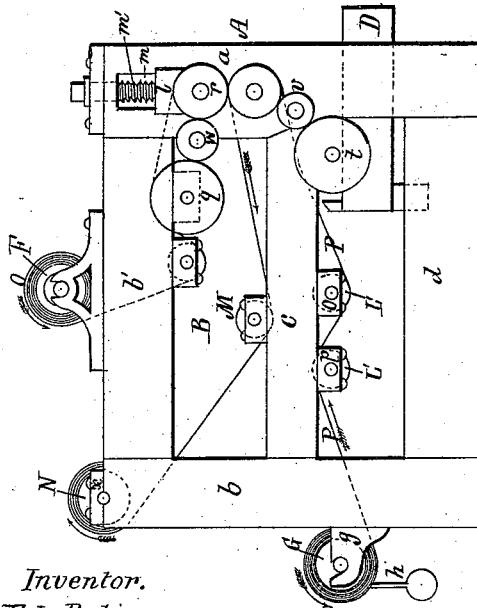

Fig. 2.



Witnesses.
W. Boardman
J. Hinnewell

Inventor.
E. L. Perkins.
J. Curtis, Atty.

E. L. PERKINS.
MACHINERY FOR MANUFACTURING PASTE-BOARD.
No. 184,896. Patented Nov. 28, 1876.

Fig. 4.

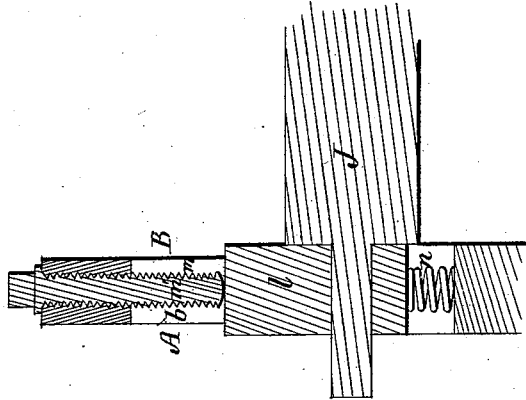
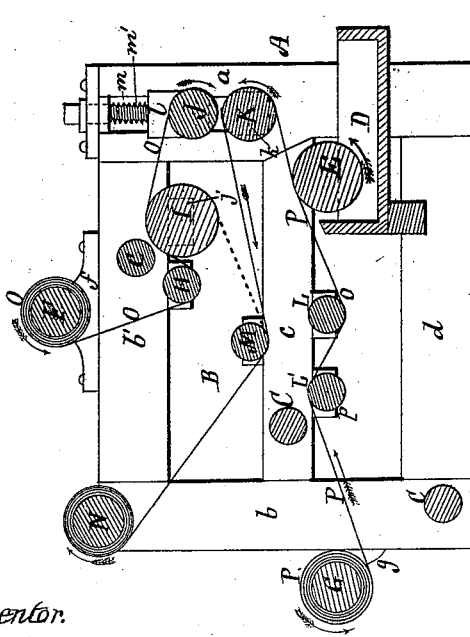

Fig. 3.



Witnesses. *W. Boardman* *E. L. Perkins*
F. Hume *H. Curtis, Atty.*

UNITED STATES PATENT OFFICE.

E. LAMSON PERKINS, OF BOSTON, MASSACHUSETTS.

IMPROVEMENT IN MACHINERY FOR MANUFACTURING PASTEBOARD.

Specification forming part of Letters Patent No. 184,896, dated November 28, 1876; application filed October 14, 1876.

To all whom it may concern:

Be it known that I, E. LAMSON PERKINS, of Boston, Suffolk county, Massachusetts, have invented new and useful Improvements in the Manufacture of Paper-Boards, of which the following is a specification:

This invention relates to the uniting, by the use of suitable paste or cement, two or more sheets or rolls of paper, to produce thick papers or boards; and the machine which embodies my present invention contains devices for supporting the rolls of paper and allowing them to be drawn along as occasion requires; of a suitable paste reservoir or fount, for containing a supply of paste; of a distributing or delivering roll, for conveying the paste to the surface of one or more of the sheets; of variable gage rolls or bars, for regulating the amount of paste thus delivered, by which I insure a uniformly even winding of the board upon the winding-shaft, and by which also I am enabled to admit between the sheets of paper a very large amount of paste, which forms a body of itself; and, finally, of the method of driving the entire mechanism by power transmitted from the final winding-shaft without the interposition of press or draft rolls, by which tension lateral wrinkling of the board is avoided, and the sheet of paper compelled to hug the various rolls it passes.

The drawings accompanying this specification represent, in Figure 1, a front elevation, in Fig. 2 a side elevation, and in Fig. 3 a vertical section, of a machine embodying my invention. Fig. 4 is a section of one box and journal of the paste-regulating rolls, to be hereinafter explained.

In these drawings, A represents the frame of the machine as composed of side standards or housings B B, united by suitable cross-beams C C, each standard itself being, in the present instance, composed of two uprights, *a b*, spanned by horizontal rails *b' c d*. Between the front uprights *a a*, and at the lower part thereof, I place a horizontal paste-trough, D, which rests upon such uprights, and is to be provided with a supply of paste or cement.

The paste-delivering roll is shown at E as partially submerged in the paste in the trough

D, and supported at its journals in boxes *e e*, affixed to the under side of the rails *c c*, such roll E being composed of cast-iron, or any suitable material.

The reels or beams for containing the continuous sheets of paper are, in the present instance, two in number, and shown, respectively, at F and G, the former, F, being mounted in bearings *f f*, affixed centrally, or thereabout, to the top of the side rails *b'*, and the latter, G, in boxes *g g*, affixed to the rear lower part of the uprights *b*, and each beam or its pulley being provided with a friction-strap, *h*, which, by friction upon the beam or its pulley, causes a drag upon the paper. H and I, in the accompanying drawings, represent two horizontal parallel rollers, placed closely together, and mounted in boxes *i j*, affixed to the under forward part of the side rails *b'*, while J and K represent a pair of rolls, placed one over the other, above the paste-trough D, and mounted at their journals in boxes *k l*, disposed within guideways *m*, created in the front uprights *a*, the boxes *k* of the lower roll K being stationary, while the boxes *l* of the upper roll J are adjustable vertically, and depressed by screws *m'*, as shown in Figs. 3 and 4 of the said drawings, a spring, *n*, being interposed between the two pairs of boxes to force the rolls apart, in order to permit the passage of a large body of paste, which press or elastic roll will not permit. L L, in the accompanying drawings, represent a pair of horizontal parallel idle-rollers, supported in boxes *o p*, depending from the central part of the rails *c*. The rollers E, I, J, and K are connected by means of a gang of connecting friction or gear wheels, *q r s t*, applied one to each roller-journal, respectively, and intermediates *v w*, as shown in Fig. 2, while the rolls F, G, H, L, L', and M are idle.

The winding beam or shaft is shown at N as mounted at its journals in boxes *x*, affixed to the upper rear corner of the rails *b'*, this shaft being driven by power applied to its end or journal, and constituting the sole driving agent of the machine, the entire mechanism being operated by draft from the paper as it is wound upon such shaft.

The upper continuous sheet O of paper from

the drum F is led downward below the roll H; thence upward between the latter and the roll I, and over the said roll I; thence over the roll J, and between it and the roll K; and thence under the roll M, and from the latter to the winding-shaft N.

The lower sheet P of paper from the drum G is led over the roll L'; thence downward between such roll and the roll L, and below the latter; thence over and in contact with the paste-delivering roll E; thence upward between the rolls K and J, and joining the upper sheet, and passing in company with it through the latter rolls; thence, under the roll M, is wound with it about the shaft N.

For certain purposes it is preferable to change the direction of the upper sheet of paper by carrying it from the roll H about the roll I, and joining the pasted sheet beneath the roll M, as shown in dotted lines in Fig. 3 of the drawings, thus avoiding carrying the two sheets together between the gage-rolls J K. The lower sheet P receives from the paste-roll E (which, as shown by the arrow, runs in a direction opposite to that taken by the lower sheet) a coat of paste, which serves not only to cement the two sheets of paper together, (which is the object of previous system,) but to interpose a body of paste, which, as before intimated, constitutes in itself a hard body, which adds to the stiffness and body of the product, and gives a result not attainable in other ways.

To obtain a tension or drag upon the united sheet, by which to insure a compact and uniformly perfect union of them as they accumulate above the winding-shaft, and to prevent the wrinkled and uneven surface of the board which would result if the tension or drag upon it was relaxed, I weight the journals of the supply-drums F and G, as before stated, as by this means any requisite amount of tension may be obtained.

The united sheets of paper reach the final winding-shaft before the moisture of the paste has had time to thoroughly permeate them.

As the sheets become moist after the winding upon the shaft begins, the swelling and expansion due to the moisture from the paste creates a powerful pressure, which compacts and solidifies the entire coil of board or thick paper, and insures a perfect union of the two sheets. As the draft upon the two sheets, throughout the entire process, comes entirely from the winding-shaft, wrinkling or ribbing will be avoided, which would naturally result were the winding-shaft connected with the rest of the mechanism, or if interposed draft or press rolls were employed. For the same reason no compensating or regulating mechanism is necessary, as each sheet travels freely from its roll to the winding-shaft.

The rolls J and K perform an important office, in that they govern the thickness of the body of paste delivered upon the lower sheet interposed between the two, and thus

prevent the spiral winding of the board about the arbor, which would result did its thickness vary upon opposite sides.

The rolls J and K are in no sense pressure-rolls, as will be instantly seen—in fact, the upper roll is forced away from the lower roll by powerful springs. Pressure-rolls in this locality, which are, as before stated, essential to the success of machines heretofore in use, would be fatal to the success of mine, as my gage-rolls are intended to constitute a gate or gage to admit of the passage of a comparatively large body of paste, varying in thickness with circumstances.

In the production of certain classes of thick papers, which I am now manufacturing in large quantities, it is necessary to admit a thick body of paste between the various sheets of paper, which body, as before stated, forms a hard intermediate body. If the sheets of paper, after being pasted, are led between pressure-rolls, or subjected to the action of a doctor, as has been the practice prior to my present invention, the paste is expressed to such an extent as to leave only a thin film, entirely inadequate to my purposes, and the object heretofore in employing press-rolls has been to remove all surplus paste.

It will be seen that in my machine the pasted sheets do not, as in other machines, (in which press or draft rolls are employed,) lead through an arbitrary contracted space under pressure, but are free to maintain any thickness which may be permitted by the space between the gage-rolls J and K; and my object in leading the sheets of paper through the machine by draft, as exerted by the winding reel or shaft, is in part to avoid the crowding out of the paste, and in part to avoid the wrinkling and ribbing of the material, which results to a greater or less extent when carried through pressure-rolls, as it is well known to experts in the manufacture of paper that the edges of the sheet are always longer, and consequently looser, than the center, and in passing two sheets with paste interposed between press-rolls which exclude all but a very thin film of paste, especially if these press-rolls act to draw the material along, a greater or less amount of wrinkling unavoidably takes place.

Before proceeding to manufacture a quantity of thick paper or board I set the gage-rolls to admit a given amount of paste, which amount is predetermined upon, as I determine before commencing how much paste I shall incorporate with a given amount of paper.

Furthermore, an important result of the use of my variable gage-rolls is, that if the sheet of paper varies in thickness in different points, which frequently occurs, the thickness in paste varies in accordance therewith, and a board of uniformly even thickness is obtained.

I consider the essence of my machine to

consist in the adjustable or variable gage-rolls in connection with the method by which the pasted material is led along and reeled without removal of the paste, no matter what amount of paste may be used.

Having thus described my invention, what I claim, and desire to secure by Letters Patent, is—

In machinery for making paper-board, in combination with a power winding-roll, the

gaging rolls or bars to measure the quantity of paste which is carried into and interposed between, and to be embodied in with, the several sheets of paper, substantially as set forth.

E. LAMSON PERKINS.

Witnesses:

F. CURTIS,

W. E. BOARDMAN.