

W. F. PERRY. N.

MACHINES FOR CORRUGATING SHEET-METAL.

No. 184,897.

Patented Nov. 28, 1876.

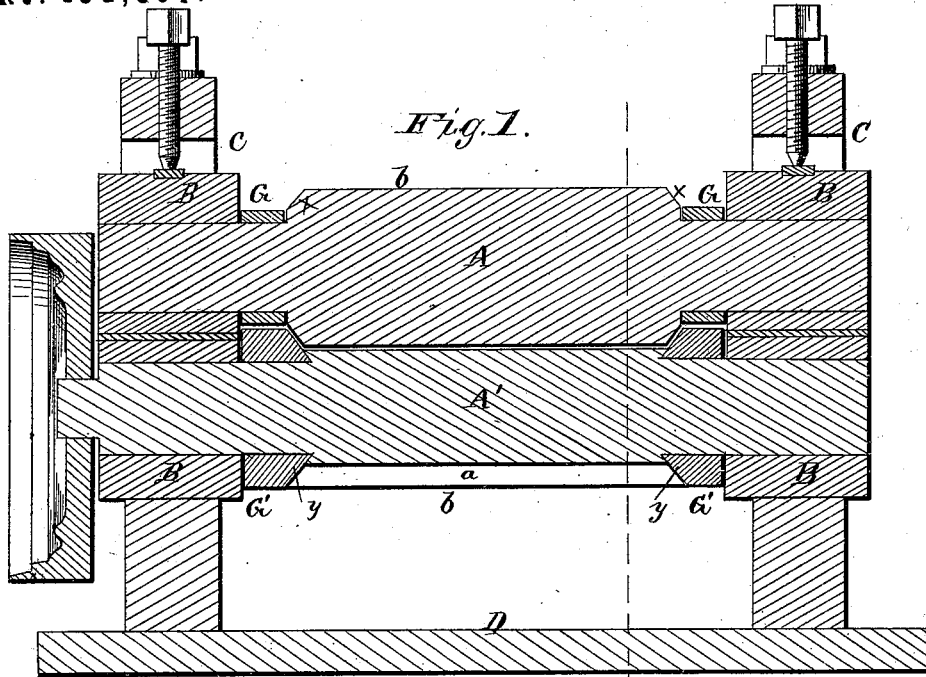

Fig. 1.

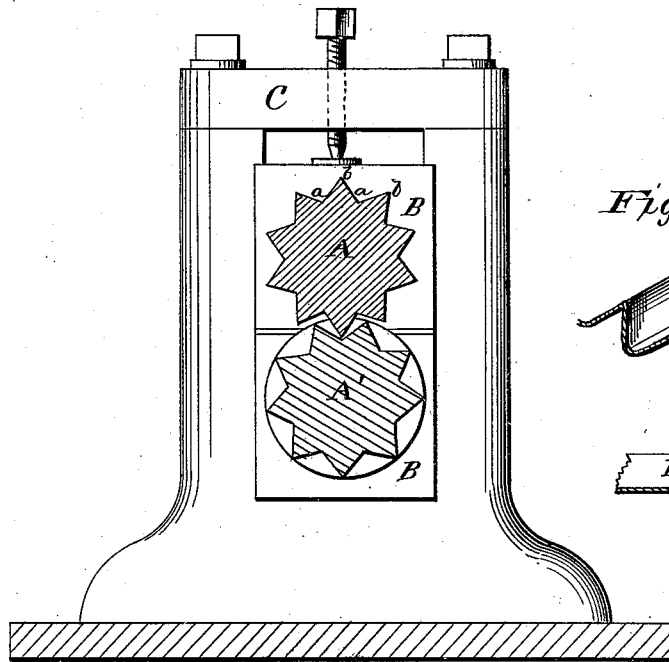

Fig. 2.

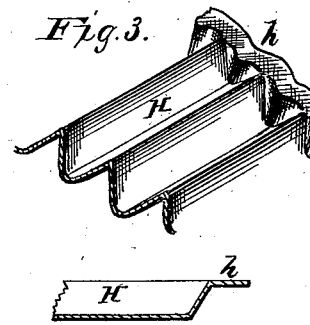

Fig. 3.

WITNESSES
Frank L. Curand
Henry N. Miller.

INVENTOR
William F. Perry
Alexander Mason
ATTORNEYS

UNITED STATES PATENT OFFICE.

WILLIAM F. PERRY, OF TOLEDO, OHIO.

IMPROVEMENT IN MACHINES FOR CORRUGATING SHEET METAL.

Specification forming part of Letters Patent No. 184,897, dated November 28, 1876; application filed October 18, 1876.

To all whom it may concern:

Be it known that I, WILLIAM F. PERRY, of Toledo, in the county of Lucas, and in the State of Ohio, have invented certain new and useful Improvements in Zinc-Crimping Machines; and do hereby declare that the following is a full, clear, and exact description thereof, reference being had to the accompanying drawings, and to the letters of reference marked thereon, making a part of this specification.

My invention relates to machines for crimping zinc for wash-boards; and it consists in the construction of the crimping-rollers, as will be hereinafter more fully set forth.

In order to enable others skilled in the art to which my invention appertains to make and use the same, I will now proceed to describe its construction and operation, referring to the annexed drawing, in which—

Figure 1 is a longitudinal vertical section of a zinc-crimping machine embodying my invention. Fig. 2 is a transverse vertical section of the same. Fig. 3 shows a section of the zinc as crimped by my machine.

A A' represent the crimping-rollers, the journals of which are placed in boxes or bearings B B, said boxes being arranged in vertically-slotted standards c c, secured on a suitable base, D. The rollers A A' are corrugated longitudinally, forming alternate grooves *a* and projections *b*. The roller A is, at each end, provided with a collar, G, of such diameter that its periphery will be on a line or flush with the bottom of the grooves *a*, and the ends of the projections are beveled down, as shown at *x*—that is, so that the base of each projection will be longer than the outer edge.

On each end of the roller A' is placed a collar, G', of such diameter that its periphery will be on a line or flush with the outer edges of the projections *b*, and the ends of said projections are beveled inward from the outer

edge to the base. The inner ends of the collars G' are made conical to fit in said bevels, and form an incline, *y*, at each end of each groove *a*.

The collars G and G' being of unequal diameter, as described, when the zinc is passed through between the rollers, a straight edge, *h*, will be left on it, as shown in Fig. 3, said straight edge being in the same plane as the outer edges of the projections or ridges of the zinc.

The zinc H is provided with such straight edge *h* on each side, to fit into a narrow jaw-kerf on each side of the board to hold the zinc in place, and said straight edges being at one side of the crimp, the water will all drip down on the zinc, instead of running into the grooves or kerfs cut in the side pieces, as is the case when the zinc is crimped clear across and the kerf cut wide enough to admit it.

The collars G G' may be made fast on their respective rollers, though I prefer to make them loose thereon.

The zinc is cut a little wider than the flutes or corrugations in the rollers, and passed through, leaving a straight edge on each side.

Having thus fully described my invention, what I claim as new, and desire to secure by Letters Patent, is—

In a machine for crimping zinc for wash-boards, the fluted or corrugated rollers A A', provided upon their ends with collars G G and G' G' respectively, of unequal diameter, substantially as shown and described, and for the purposes herein set forth.

In testimony that I claim the foregoing I have hereunto set my hand this 30th day of September, 1876.

WILLIAM F. PERRY.

Witnesses:

A. T. BARNES,
M. E. DOOLITTLE.

*T. S. O.
words*