

E. W. DENNISON.  
CASES FOR TOILET PAPER.

No. 185,082.

Patented Dec. 5, 1876.

Fig. 1.

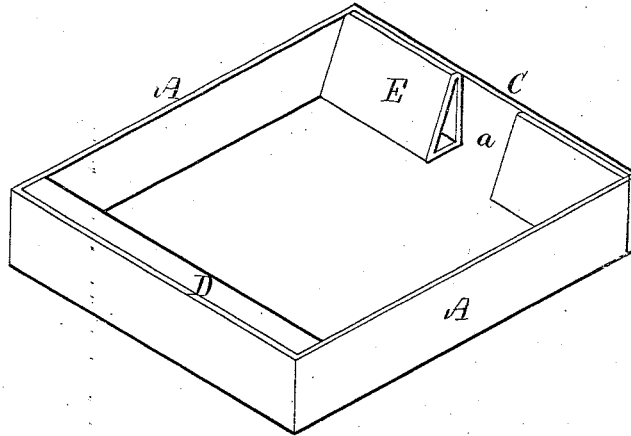
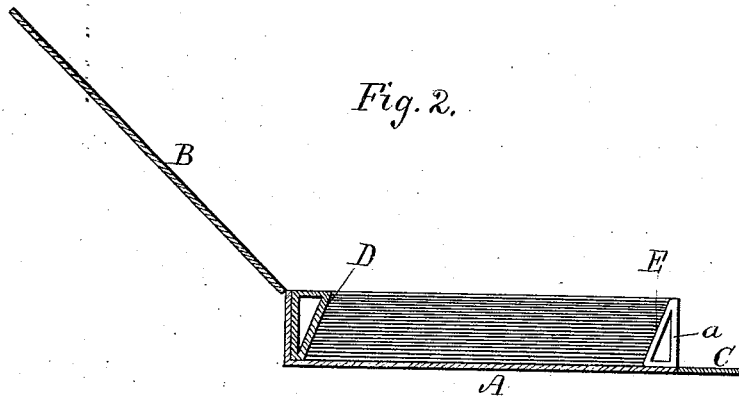

Fig. 2.



Witnesses.  
Louis A. Curtis  
H. E. Boardman.

Inventor:  
E. W. Dennison  
J. Curtis, Atty.

# UNITED STATES PATENT OFFICE.

ELIPHALET W. DENNISON, OF BOSTON, MASSACHUSETTS.

## IMPROVEMENT IN CASES FOR TOILET-PAPERS.

Specification forming part of Letters Patent No. **185,082**, dated December 5, 1876; application filed September 18, 1876.

*To all whom it may concern:*

Be it known that I, ELIPHALET W. DENNISON, of Boston, Suffolk county, Massachusetts, have invented a new and useful Case for Toilet or Shaving Papers, of which the following is a specification:

The purpose of this invention is to provide a neat and useful receptacle for shaving or toilet papers, by which the latter are always retained in a compact state, and prevented from becoming scattered or lost—the position of the papers within the case being such that a single sheet may, if desired, be readily detached from the pack without disturbing the remainder.

The invention consists in the employment of a box or case whose front and rear sides are sloping, in order that the upper sheets of the pack shall overhang those below and be readily detached, while, secondarily, the front sloping side or wall is formed with a notch to receive a person's thumb and enable access to be readily had to the uppermost sheets as the pack becomes reduced, and the adjacent side of the box is hinged at bottom to expose such notch, the whole being as hereinafter described.

The drawings accompanying this specification represent, in Figure 1, a perspective view of a box or case embodying my invention, while Fig. 2 is a vertical section of the same.

In these drawings, A represents a rectangular box, composed of paper or any suitable material, such box being provided with a cover, B, and with its front side C hinged to the bottom, in order to drop and expose the contents of the box, and enable access to be had to the latter. The rear inner side D of the box A is sloping or overhanging, as shown in Fig. 2 of the drawings, while the opposite

side E is sloping in the same direction, or parallel to it. The purpose in inclining the sides D and E, and of the box is to crowd the ends of the pack of paper into a like position, in order that the upper sheets shall overhang to a slight extent those below, and thus render the removal of the upper one more certain and easy.

To aid in readily detaching the upper sheet of the pack, a notch, *a*, may be cut in the sloping wall E, to admit of passage of a person's thumb to the uppermost sheet as the pack becomes gradually reduced, and to permit of this passage of the thumb the front side C of the box may be hinged at bottom, in order to be turned down into a horizontal position, as shown in Fig. 2 of the drawings.

The notch *a* may be of any form or size, and it may be dispensed with entirely; but I prefer to employ it, as well as to hinge the front side of the box, as stated.

The cover B may be omitted, if desired; but in most cases it will be employed.

A receptacle of the character above named will be found attractive and useful, as it prevents packages of toilet or shaving papers from becoming loose and scattered about, while at the same time it permits a single sheet to be readily and immediately detached.

I claim—

A box having hinged or removable end flap and cover, provided with additional parallel sloping walls, one of which (the one over which the sheets are withdrawn) has a thumb-notch, the whole being arranged substantially as described.

E. W. DENNISON.

Witnesses:

ALBERT METCALF,  
W. E. BOARDMAN.