

W. L. REYNOLDS & E. E. SLUDER.

SMELTING FURNACE.

No. 185,132.

Patented Dec. 5, 1876.

Fig. 1.

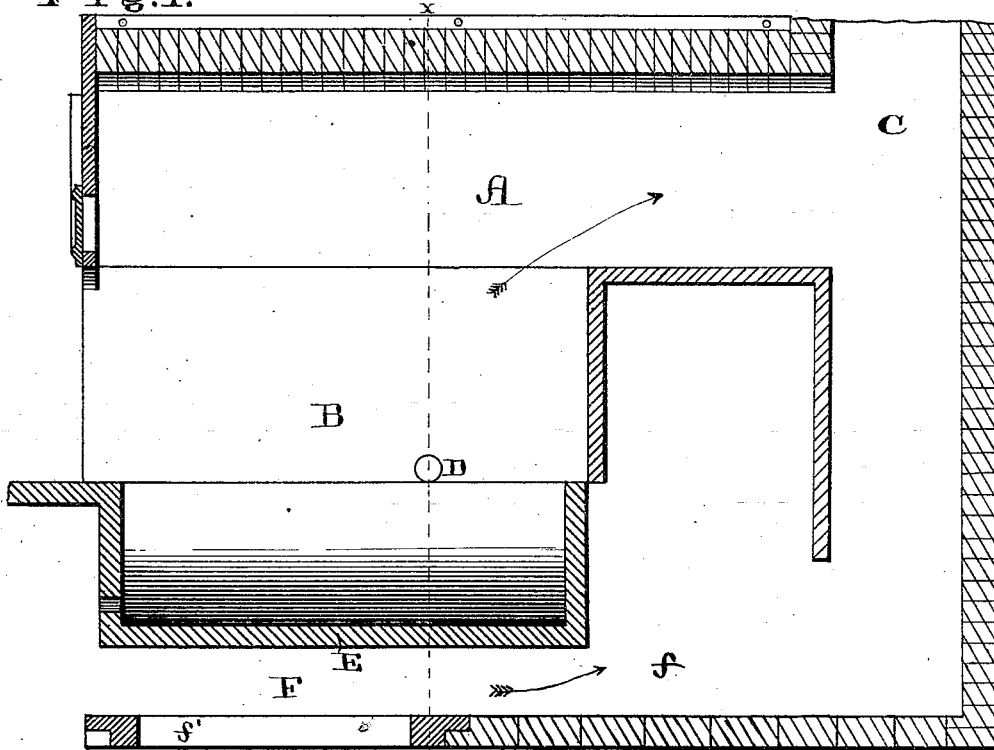
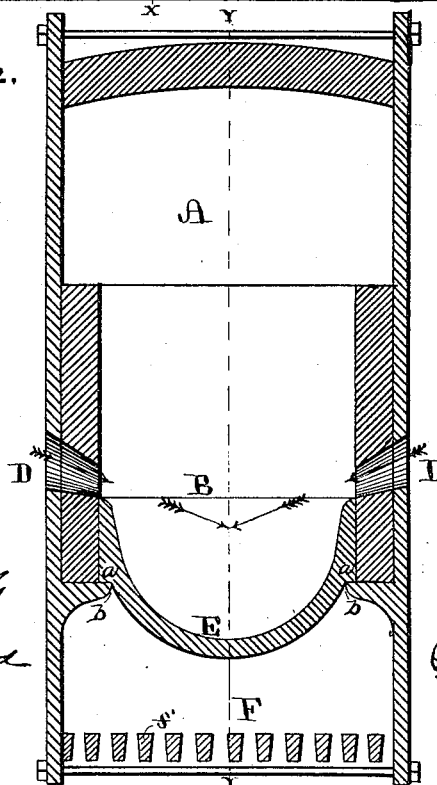

Fig. 2.



WITNESSES.

Charles Pickles
Saml. S. Boyd

INVENTOR.

William R. Reynolds,
Edwin E. Sluder
by Chas. S. Moody,
att'y

UNITED STATES PATENT OFFICE

WILLIAM L. REYNOLDS AND EDWIN E. SLUDER, OF ST. LOUIS, MISSOURI,
ASSIGNORS OF PART OF THEIR RIGHT TO WM. B. DEAN, CHARLES D.
MOODY, AND SAMUEL S. BOYD, ALL OF SAME PLACE.

IMPROVEMENT IN SMELTING-FURNACES.

Specification forming part of Letters Patent No. 185,132, dated December 5, 1876; application filed
March 28, 1876.

To all whom it may concern:

Be it known that we, WILLIAM L. REYNOLDS and EDWIN E. SLUDER, both of St. Louis, Missouri, have invented a new and useful Improvement in Smelting-Furnaces, of which the following is a full, clear, and exact description, reference being had to the annexed drawing, making part of this specification, in which—

Figure 1 is a longitudinal sectional elevation taken on the line *yy* of Fig. 2, and Fig. 2 a cross-sectional elevation taken on the line *xx* of Fig. 1.

Like letters indicate like parts.

The present invention relates more especially to furnaces for smelting copper and lead.

Referring to the annexed drawing, A represents a furnace embodying the present improvements. It is an open furnace, similar to what is known as a forge-fire. B represents the fire-place, and C the escape-flue. D D represent tuyeres. E represents the bottom of the furnace. It is preferably made circular in cross-section, as shown in Fig. 2. Underneath the bottom is arranged a fire-place, F, which is provided with an escape-flue, *f*, leading, preferably, into the flue C. The fire-place F is also provided with suitable grate-

bars *f'*. The bottom E of the furnace is made detachable, so that it can be withdrawn, and, if desired, readily renewed. It can also be adjusted longitudinally by properly elevating the rear end.

In operation, while the smelting is going on in the furnace A above, a fire is maintained in the fire-place F below. By this means the bottom of the furnace is kept warm, and the contents of the furnace prevented from chilling upon the furnace-bottom. By reason of the shape of the furnace-bottom the molten metal collects in the center, where it can be tapped. The bottom of the furnace being detachable, it can be renewed when worn or burned out. This furnace-bottom rests, by flanges *a*, upon ways *b* projecting from the walls of the furnace, and is adapted to slide on these ways and to be drawn out at the front without disturbing the brick-work.

What we claim is—

The combination of the furnace A, fire-place B, sliding bottom E, and fire-place F, substantially as described and shown.

WM. L. REYNOLDS.
EDWIN E. SLUDER.

Witnesses:

CHAS. D. MOODY,
WM. B. DEAN.