

J. H. ASH.
 PIPE CONNECTION.

No. 185,156.

Patented Dec. 12, 1876.

Fig 1.

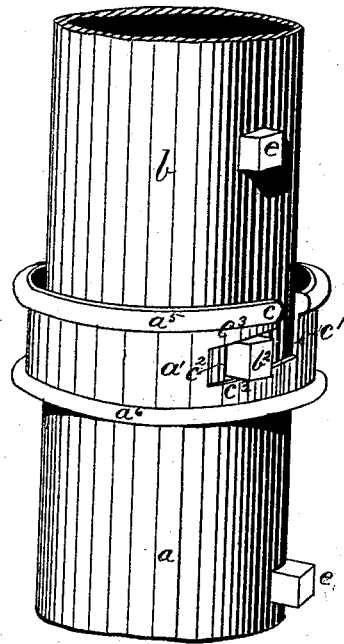

Fig 2.

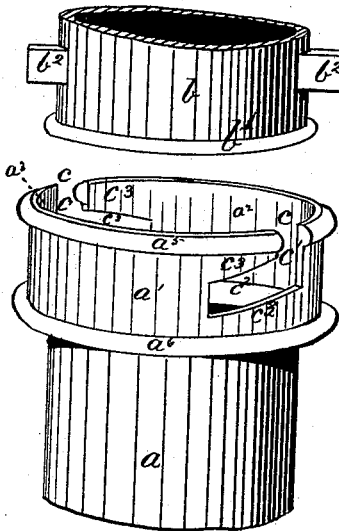

Fig 4.

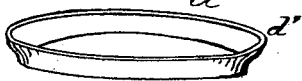
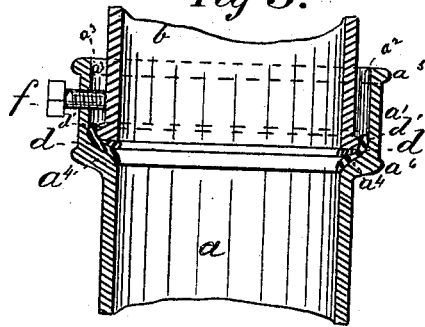

Fig 3.



Witnesses.
 B. C. Fole.
 R. H. Lacey

Inventor.
 Joseph H. Ash,
 By R. S. & A. Lacey
 Attorneys.

UNITED STATES PATENT OFFICE.

JOSEPH H. ASH, OF BROOKLYN, NEW YORK.

IMPROVEMENT IN PIPE-CONNECTIONS.

Specification forming part of Letters Patent No. 185,156, dated December 12, 1876; application filed August 23, 1876.

To all whom it may concern :

Be it known that I, JOSEPH H. ASH, of Brooklyn, in the county of Kings and State of New York, have invented certain new and useful Improvements in Pipe-Connections; and I do hereby declare that the following is a full, clear, and exact description thereof, which will enable others skilled in the art to which it pertains to make and use the same, reference being had to the accompanying drawing, and to the letters of reference marked thereon, which form a part of this specification.

My invention relates to improvements in that class of pipe-couplings specially adapted for connecting together the ends of heavy metal sections to form continuous pipes or mains for conveyance of water, gas, or steam, the nature of which will be fully explained by reference to the accompanying drawings, in which—

Figure 1 represents a perspective view of portions of two pipes, connected together according to my invention. Fig. 2 shows a similar view of the two portions separately. Fig. 3 is a vertical section of parts in the position shown in Fig. 1, and Fig. 4 is a detached perspective view of the washer.

In each of the views similar letters of reference are employed to indicate corresponding parts wherever they occur.

a and b represent the portions of two sections of pipe to be connected together, the section a being formed with an enlargement, a^1 , adapted to receive within it the end of the section b , which, at its extremity, is provided with an annular enlargement, b^1 , formed semi-circular in cross-section, as shown by Fig. 3.

The internal face or wall a^2 a^3 of the enlargement a^1 is formed smooth or entirely free from projecting shoulders or bearings, and terminates in a bell-shaped seating, a^4 , adapted to receive the washer d , which is firmly compressed between the enlargement b^1 and the seat a^4 , when the sections a and b are brought together, as shown in Figs. 1 and 3.

By the peculiar construction of the parts, as shown, an annular space is left all around the section b , within the enlargement a^1 , adapted to receive additional calking material when required, and also for the insertion

of calking-tools, for the purpose of pressing down the edge d' of the packing-ring d .

The sections a and b are held together by means of studs or projections b^2 formed on the exterior of part b , which are adapted to be received into the vertical portion c^1 of the L-shaped slots c , and, when so received, of being turned so as to pass between the parallel inclined surfaces c^3 of the part c^2 of the slots c , thereby drawing the ends of the pipe gradually nearer together, and compressing the washer d tightly between the enlargement b^1 and the seat a^4 . $e e$ are enlargements formed on the parts a and b , for the purpose of facilitating the turning of said parts for the purpose of connecting or disconnecting the same.

The section c^1 of the slot c being formed parallel with the axis of the pipe enables the sections to be brought together and held steadily in position before being turned and finally connected thereby, facilitating adjustment and saving great labor to the workmen. The section c^2 of the slot c is formed at nearly right angles to the axis of the pipe, being only inclined sufficiently to act as a slight draw on the pipes when the latter are turned.

The straight and slightly-inclined bearing-edge c^3 enables the workmen to turn the pipes easily and with powerful force against the washer, and, when once the connection is made, there is little or no liability of the said sections of pipe being loosened by slight or ordinary jarring or vibration, as is the case where long continuously-curved slots are employed.

When the pipes are to be employed above ground, or in positions where they will be subjected to very great disturbances from vibrations or other causes, I employ a set-screw, f , applied through the straight portion of the enlargement a^1 , and adapted to bear against the periphery of the part b when the latter has been placed in position and packed, thereby preventing any possibility of displacement of the sections.

The washer d is formed of lead or other soft metal employed in packing pipe-joints. It is formed without a seam, and is cut and stamped by suitable machinery into a bell shape, as shown, so that it will fit neatly over the seat

a^4 , with a portion, d' , of its larger end resting against and lying slightly along the inner face of the enlargement a^1 , and between the latter and the annular projection b^1 of the pipe b .

When the pipes are first brought together by sliding the projections b^2 into parts c^1 of the slots c , the annular rim b^1 is received within the larger end d' of the washer d ; and when the pipes are drawn together by the action of the projections b in the slots c^2 , the edge d' of said washer projects slightly beyond the rim b^1 , so that it may be hammered down by suitable calking instruments inserted within the space between the enlargement a^1 and the end of the pipe b .

By this arrangement, it will be readily seen that a perfectly-tight joint may be made. The slots c^2 afford facilities for the use of calking implements in the process of hammering down of that part of the edge d' opposite said slots.

It will be seen that by this construction a connection is made in which a space about the end of the pipe is provided, which space is entirely free from obstructions, except that offered by the narrow projections b^2 , and that further calking than that provided by the washer d may be readily done when desired—a result which cannot be obtained where extended inner projections are formed on the inner surface of the enlarged end a^1 .

Having thus described my invention, I would have it understood that I do not claim, broadly, connecting together the ends of sections to form continuous pipes by means of projections on one section taking into or being retained by retaining portions on the other section; but

What I do claim, and desire to secure by Letters Patent, is—

The combination, with a section provided with an enlargement, a^1 , having its inner face or wall $a^2 a^3$ formed smooth or free from projecting shoulders or bearings, and terminating in a bell-shaped bearing, a^4 , and provided with L-shaped slots c , having straight portions c^1 and inclined portions c^2 , and set-screw f , of the washer d , made bell shape, with the extended portion d' and section b having a semicircular annular projection b^1 formed on its extremity, and studs or projections b^2 , the whole being constructed, arranged, and operating in the manner as and for the purpose shown and described.

In testimony that I claim the foregoing as my own I affix my signature in presence of two witnesses.

JOSEPH H. ASH.

Witnesses:

R. H. LACEY,
E. ASH.