

M. BENJAMIN.  
HORSESHOE MACHINE.

No. 185,161.

Patented Dec. 12, 1876.

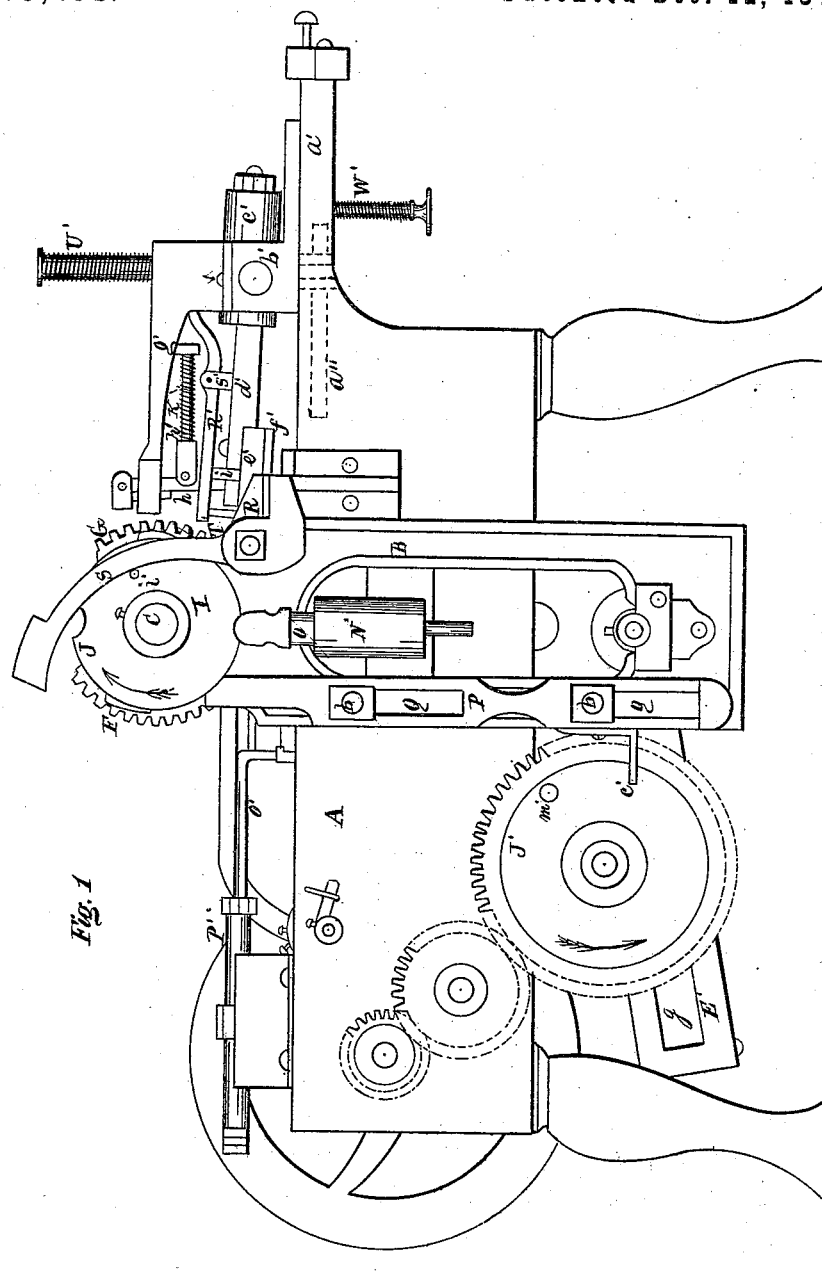

Fig. 1

Witnesses  
*M. Kelley*  
*J. H. Burridge*

Inventor  
*Mr. Benjamin*  
*Per. Burridge & Co.*  
*Atty.*

M. BENJAMIN.  
HORSESHOE MACHINE.

No. 185,161.

Patented Dec. 12, 1876.

Fig. 2

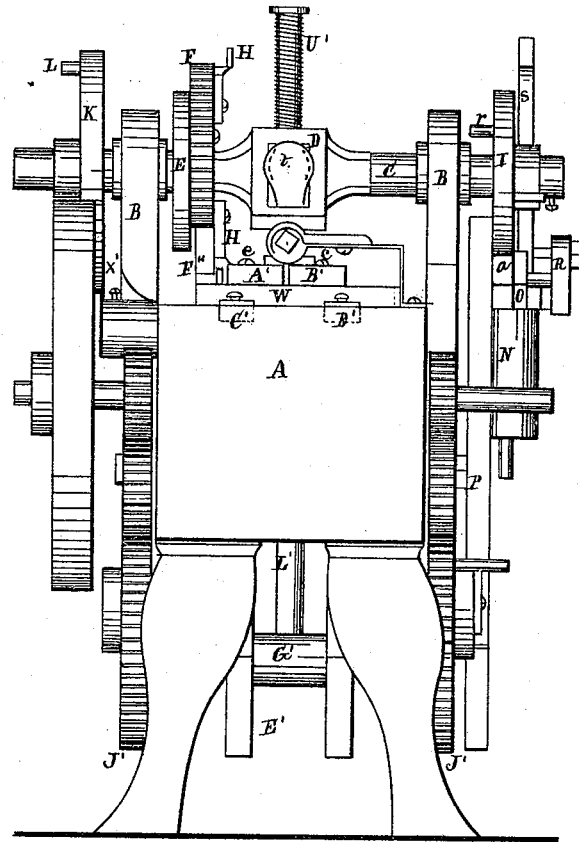
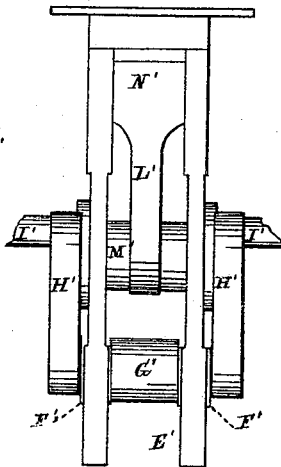

Fig. 18.



Witnesses  
*W. A. Kelley*  
*J. H. Burridge*

Inventor  
*M. Benjamin*  
*Per Burridge & Co.*  
*Atty.*

M. BENJAMIN.  
HORSESHOE MACHINE.

No. 185,161.

Patented Dec. 12, 1876.

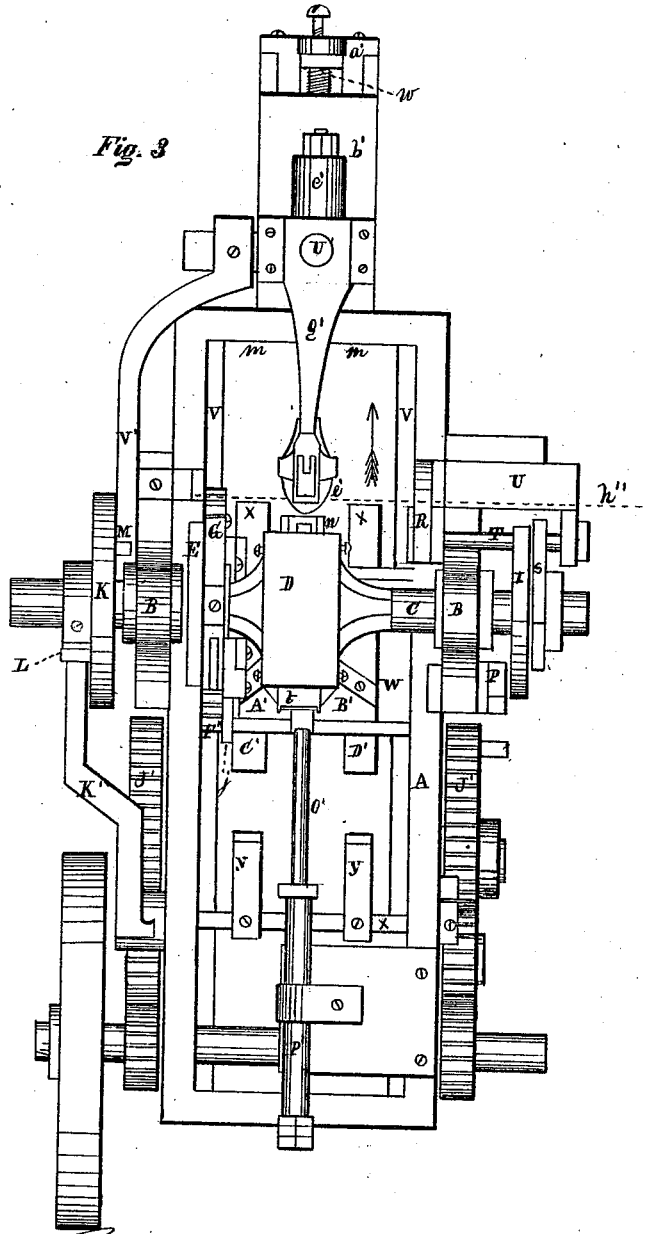

Witnesses  
*W. A. Kelley*  
*J. M. Burridge*

Inventor  
*M. Benjamin*  
*Per. Burridge & Co.*  
*Attys.*

M. BENJAMIN.  
HORSESHOE MACHINE.

No. 185,161.

Patented Dec. 12, 1876.

Fig. 4

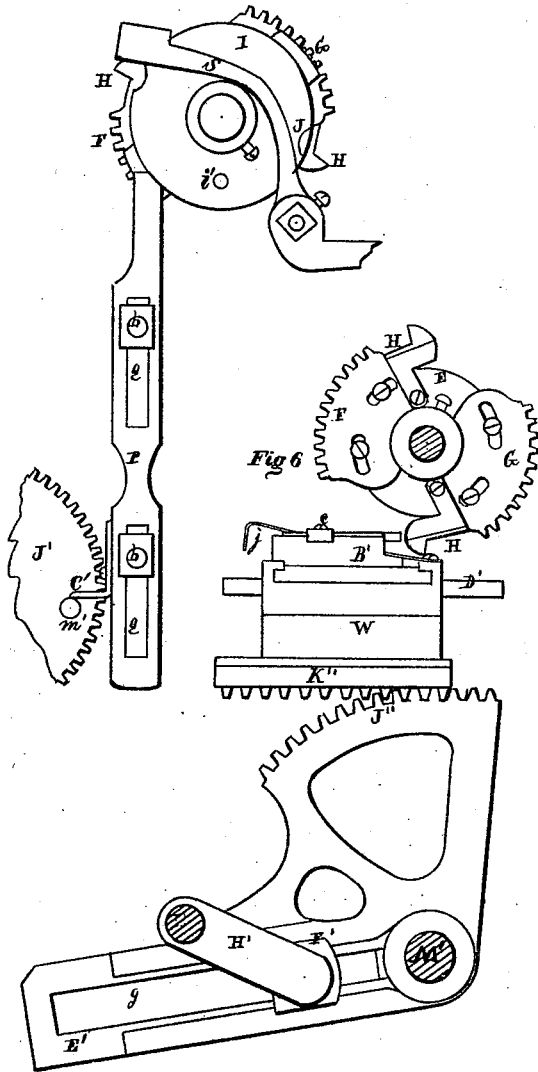

Fig. 5

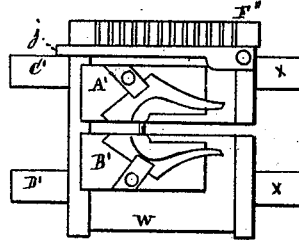

Fig. 6

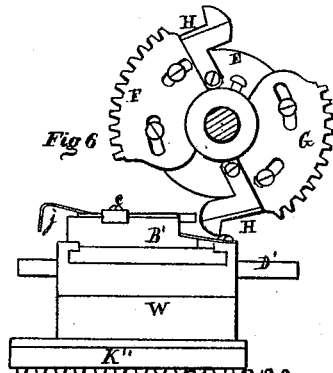
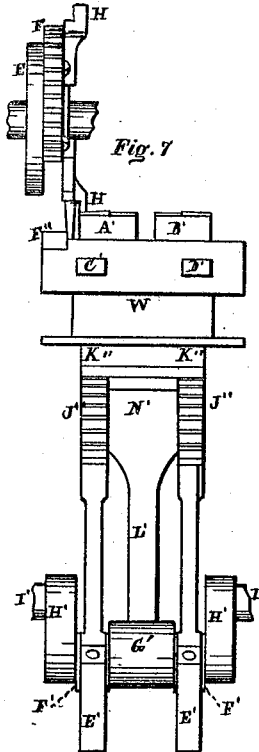

Fig. 7



Witnesses  
*M. Kelly*  
*J. H. Burridge*

Inventor  
*M. Benjamin*  
*Per. Burridge & Co.*  
*Attys.*

M. BENJAMIN.  
HORSESHOE MACHINE.

No. 185,161.

Patented Dec. 12, 1876.

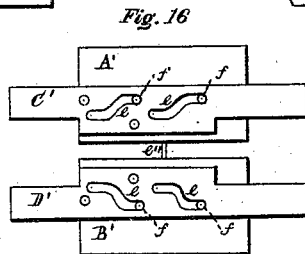
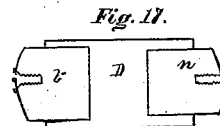
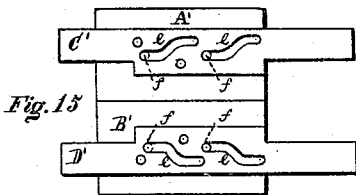
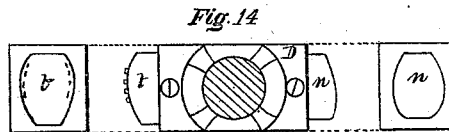
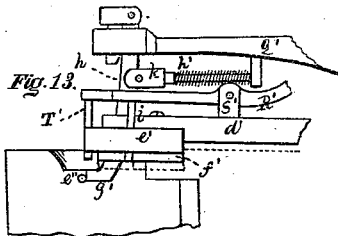
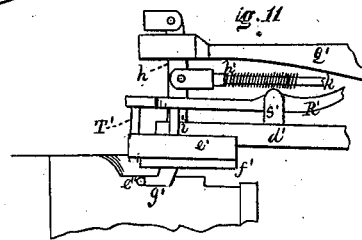
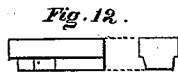
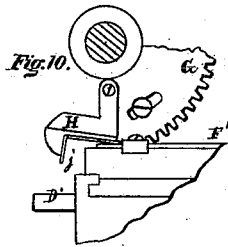
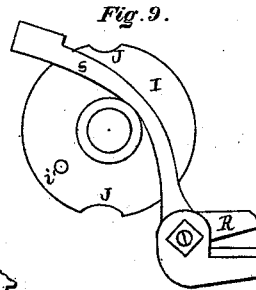
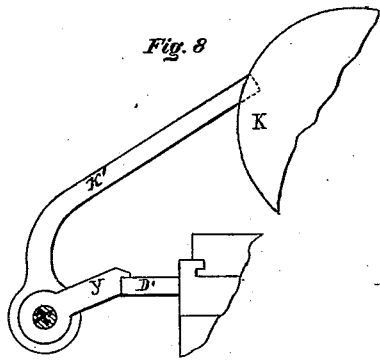

Witnesses  
*W. H. Kelley*  
*J. H. Burridge*

Inventor  
*M. Benjamin*  
*Per Burridge & Co.*  
*Atty.*

# UNITED STATES PATENT OFFICE.

MYRON BENJAMIN, OF CLEVELAND, OHIO, ASSIGNOR TO SAMUEL M. CARPENTER AND WILLIAM F. SMITH, OF SAME PLACE.

## IMPROVEMENT IN HORSESHOE-MACHINES.

Specification forming part of Letters Patent No. 185,161, dated December 12, 1876; application filed September 18, 1876.

*To all whom it may concern:*

Be it known that I, MYRON BENJAMIN, of Cleveland, in the county of Cuyahoga and State of Ohio, have invented new and useful Improvements in Horseshoe-Machines, of which the following is a description, reference being had to the accompanying drawings, making a part of this specification, in which—

Figure 1 is a side elevation of the machine; Fig. 2, an end elevation, and Fig. 3, a plan view.

The rest of the views presented are detached sections, to which reference will be made.

Like letters of reference refer to like parts in the several views.

The nature of this invention relates to a machine for making horseshoes, of which the following is a detailed description of the construction and operation of the same.

To each side of a frame A is secured a housing, B, Fig. 2, the upper end of which affords bearings for the trunnions or shaft C, carrying a die-head, D, Fig. 3. A further description of the head and dies will hereinafter be made. On said shaft C is secured a wheel, E, Figs. 2 and 3, to the side of which is secured, in an adjustable manner, segments of gear F G, a detached view of which is shown in Figs. 6 and 7, Plate 4. To each of the segments is attached an arm, H. The purpose of said segments and arms will presently be shown. On one end of the shaft C is secured a wheel, I, Fig. 1, in the two opposite sides of which is a notch, J, shown also in the detached views, Figs. 4 and 9. On the opposite end of the shaft is secured a wheel, K, Figs. 2 and 3, from the outer side of which projects a pin, L, and from the inner side a pin, M, Fig. 3. To the housing B, directly under the wheel I, is attached a sleeve, N, Fig. 1, in which is fitted a slide, O, in the head of which is a roller, a, Fig. 2, of a size to engage the notches J referred to, and which is forced upward therein, and upon the periphery of the wheel upon which it runs, by a spring inclosed in the sleeve N around the slide for that purpose. P, Figs. 1 and 2, is a slide attached to one of the housings B by screws b inserted in slots g, which permit the movement of the slide. Directly in front of the

wheel I is a shear, R, operated by an arm, S, secured to the shaft T, carrying the shear. Said shaft has its bearings in a stay, U, Fig. 3. Within the frame A, upon the ledges V, is a carriage or bed, W, Figs. 2, 3, and 6, whereon is arranged a two-part die, consisting of sections A' B', detached views of which are shown on Plates 4 and 5, and which, when the two sections are closed, as shown in Fig. 15, (an under-side view of the die,) is in its contour the shape of a horseshoe. Said die opens and closes laterally by means of a pair of slides, C' D', in which are slots e. In each of said slots is a pin, f, projecting downward from the bottom of each of the sections A' B' of the die. Hence, as the slides are moved longitudinally the sections are moved thereby laterally, for opening and closing the die, as shown in Plate 5, in which Fig. 15 shows the die as closed, and Fig. 16 as when open.

The means for actuating the slides for opening and closing the die will hereinafter be shown.

A reciprocating movement is given to the bed carrying the die by the following devices: In the lower end of the housings B referred to is journaled a segmental lever, E', Figs. 1 and 2, detached views of which are shown in Figs. 6 and 7, also in Fig. 18, in which it will be seen that said lever consists of two arms, constituting a pair of levers, in each of which is a slot, g, wherein is fitted sliding boxes F', the journal-seats of the wrists G' of the cranks H', Figs. 6 and 7. The shafts I' of said cranks have their bearings in hangers depending from the sides of the frame A, and to which said shafts are secured the cog-wheels J' respectively, and whereby the cranks are actuated for operating the lever or levers E'.

The upward arms of the lever are segments of gear J'', which are made to engage corresponding racks K'', Figs. 6 and 7, on the under side of the carriage or bed of the die, or sections thereof, A' B'. L' is an arm, the lower end of which is secured to the shaft M' between the levers E', as will be seen in Fig. 18. The upper end of said arm terminates in a head, N', and whereon the bed or carriage W of the die rests, said bed and die being mainly

supported thereby and partially by the ledges V referred to, they being in part guides for the reciprocating movement of the aforesaid bed and die, and which also prevent said bed from lifting up, it being secured to the under side of the guides by gibs. O' is a bar, held loosely in a sleeve, P', and which is moved forward toward the die by the recoil of a spring inclosed in the sleeve. The purpose of the aforesaid bar will presently be shown. On the ways a', Fig. 1, is fitted a carriage, b', wherein is pivoted a barrel, c'. In said barrel is secured a stem, d', on the end of which is fixed a head, e'. To the under side of said head is attached a die or former, f', the contour of which is the shape of the inside of a horseshoe. The edge of the head, as will be seen, projects beyond the edge of the die, thereby forming a shoulder above the sides or edge of the die or former. From the front end of said former projects a hook, g', Figs. 11 and 13. Said hook is the termination of a pendent vibratory arm, h, suspended from and pivoted in the end of an arm, q', as shown in Figs. 1, 11, and 13. Said pendent arm is pushed forward to its position (shown in Fig. 13) by a spring, h', and rod k, applied thereto, as shown in the drawing. R' is a lever, having its fulcrum in the stay S'. From the front end of said lever projects downward through a notch in the head e' a pin, T'; also, from each side of the end of the lever depends a pin, i. Said pin passes through the sides of the head to the edge of the die or former, as will be seen in Fig. 13. The purpose of said pins T' and i will hereinafter be shown. The outer end of said lever R' is elevated by a spring, U', thereby depressing the front end and causing a depression of the pins in the head. Said head is depressed by the vibration of the stem d', operated by an arm, V', which, in turn, is operated by the pin M, projecting from the wheel K, Fig. 3, above referred to. The upward movement of the head is caused by the reaction of the spring W', Fig. 1.

On the shaft x, Fig. 3, is secured a pair of arms, y y. Said arms are actuated, for a purpose hereinafter shown, by an arm, h', attached to the shaft bearing the arms, and extending therefrom to the wheel K, whereby it is operated by the pin L, above alluded to.

Having described the construction of the machine, we will now proceed to describe the operation of the same, which is substantially as follows: The position of the machine, as shown in Figs. 1, 2, and 3, is such as when a piece of iron for a shoe has just been cut off from a bar, and is about to be embraced by the die for bending, the cutting alluded to (which immediately precedes the arrival of the pressing-die n to the position shown in the drawing) is done by the shear R, the blade of which is raised, as shown in Fig. 9, and a bar of iron is pushed under it and across the machine in front of the lower die to a gage, as indicated by the dotted lines h'', Fig. 3. The blade of the shear is forced down by the pin i', Figs. 1

and 9, which, at the proper time, comes in contact with the arm S during the revolution of the wheel I. The piece for the shoe, on being cut from the bar, lies, as above said, in front of the lower die, between the hook g' and the head e'. The lower die, now open, is moved forward by the forward movement of the bed, operated by the segments J'' J'' of the lever or levers E', in their engagement with the racks K'' K''. This forward movement of the die bends the iron (termed a "blank") around the toe of the die or former f', under the projection of the head e', and by which the bending-blank is prevented from springing upward, and by the hook g' is prevented from bending downward or rolling over.

The blank is bent in around the sides of the former to form the heel of the shoe by the closing together of the die. This closing of the die is effected by the ends x, Figs. 3 and 5, of the slides C' D' impinging upon the end of the frame A at m, Fig. 3. As the die closes, by the influence of the slots and pins shown in Fig. 16, to the closed state shown in Fig. 15, the blank is forced around the sides of the former under the projection of the head. The pins T' and i i push the shoe from off the former, leaving it inclosed in the female or lower die, for being further operated upon by the intermittent revolving dies t n. Immediately preceding the engagement of the former with the blank, said former and the head are depressed from their raised position (shown in Fig. 1) to the horizontal position. (Shown in Figs. 11 and 13.) This depressing of the head and former is done by the arm V', which at the proper time in the revolution of the wheel K is impinged upon by the pin M, which, as above shown, operates the stem d' for that purpose. This depression of the head brings the former in horizontal relation to the lower die, in order that the blank may enter therein properly. While the blank is being bent around the toe of the former, and forced into the open die, that it may be closed thereby against the sides of the former for shaping the heel of the shoe, the head and former remain held down to the die by the arm V', which, as yet, continues its engagement with the depressing-pin M of the wheel K, said wheel at this time remaining still, together with the head D, carrying the dies t n—that is to say, during the bending of the blank about the toe of the former, and the closing in of the die by its continued forward movement. In order that the die inclosing the shoe (now bent about the former) may return, the former must first be removed from the shoe. This is effected by disengaging the arm V' from the pin M by means of the bed or carriage of the die. Thus, as the carriage or bed continues its forward movement while the blank in the die is bending, the end of the bed impinges upon the end of a rod, (indicated by the dotted lines a'', Fig. 1,) said rod being attached to the carriage b'. The said carriage is thereby pushed back so far as to cause the pin M to slip from the

end of the arm on which it will be seen in Fig. 3 to be resting. The arm being no longer held down by the pin, the stem  $d'$  will now vibrate by the reaction of the spring  $W'$ , and thereby elevate the head and former from the shoe held in the die in time for the return or rearward movement of the carriage for the die to receive the pressing-die  $n$ , which will, in due time, revolve to meet the die holding the shoe, for pressing it; also, during which time the hook  $g'$  is pushed from under the shoe by its contact with a pin,  $e''$ , Fig. 16, in the toe of the die, against which it comes in contact, in proper time, in the course of the forward movement of the die, said movement being in the direction of the arrow in Fig. 3. This movable character of the carriage  $b'$  prevents undue strain upon the die, should there be any difference in the thickness of the blanks, or the degrees of heat of the same.

The carriage may be adjusted to various widths or thickness of iron for large or small shoes by shortening up, or by extending, the rod  $a''$ , which is so connected to the carriage by adjusting-nuts as to adapt it for that purpose.

The die when closed around the shoe is prevented from opening, while the shoe therein is being operated upon, by means of the studs or pins  $f$ , which at this time are in the slots  $e$  of the slides  $C'$   $D'$ , as shown in Fig. 15, thereby effectually locking the dies as well as closing them. The die now closed around the shoe and locked, and the hook  $g'$  and the former removed therefrom, as shown in Fig. 11, the die begins to return by the now downward action of the lever or levers  $E'$  to meet and receive the pressing-die  $n$ , Fig. 3, held in the head  $D$ , detached views of which are shown in Plate 5. The head  $D$  is made to revolve, for bringing the die  $n$  into the lower die or shoe-die, holding the shoe by the engagement of the segment  $G$  with the rack  $F''$ , Figs. 3, 5, and 10, secured to the die-bed or carriage. The position of the segment in respect to the rack at the time the lower die begins to move back is such that it will not engage the rack, it not being turned far enough around to engage it at that instant, as will be seen in Fig. 1, the segment and revolving head being retained in this position by the slide  $O$ , lodged in one of the notches  $J$  of the wheel  $I$ . At the proper time in the rearward movement of the die the segment is made to engage the rack  $F''$  by means of the spring  $j$ , Figs. 3, 6, and 10, attached to one side of the die-bed, close to the side of the rack, as shown in Fig. 5, in which it will be seen that the free end of the spring projects beyond the edge of the bed, and hence in advance of the end of the rack. At the proper moment, as the bed moves back, the end of the spring will engage the hook  $H$ , attached to the segment, in advance of the rack, and so far turn the segment as to cause it to engage the rack, as seen in Fig. 10, in time for the head  $D$  to revolve and bring the die  $n$

down upon the shoe in the lower die. As the bed continues to move back, the upper die  $n$  continues to revolve, thereby rolling upon and pressing the shoe in the die, and forming on the shoe the bevel on the inner side thereof. This rearward movement of the die-bed goes so far as the segment  $J''$  of the levers  $E'$  will carry the bed, and during which movement the die will have performed its duty in pressing the shoe, and at which time the head and die have ceased to rotate, the segment  $G$  having traversed the rack  $F''$ , by which it was revolved, and is now, therefore, disengaged therefrom, with the pressing-die raised above the lower one, so that said lower die may pass under it in its return to the front end of the machine, from whence it started. This again forward movement of the die-bed is effected by the upward action of the lever or levers  $E'$  from the position shown in Fig. 6, which represents the die-bed as having passed under the revolving die and about to return to the front, as shown in Fig. 1. While the bed-die is returning to the front the upper dies are continued in their revolution by the vertical slide  $P$ , Fig. 1, which, by the timely movement of the wheel  $J'$ , brings the pin  $m'$  to the arm  $e'$ , as shown in Fig. 4, thereby pushing upward said slide, causing it to engage a pin,  $r$ , Fig. 2, whereby the wheel  $I$  is so far rotated as to revolve the head and bring the creasing-die  $t$  to the front, thus reversing the position of the head  $D$ , (shown in Fig. 3,) the die  $t$  being by this movement where the die  $n$  is shown to be in said Fig. 3. When the revolving dies have obtained this position, the slide  $P$  drops down, the pin  $m'$  having become disengaged from the arm  $e'$  of the slide. This position of the head  $D$  is maintained for a short time by the slide  $O$ , Fig. 1, being pushed upward by a spring in the sleeve  $N$  into one of the notches  $J$ , which at this time is presented to the slide. The creasing-die is now in position to engage the lower die for creasing and marking the prints in the shoe for the nail-holes, and partially punching the same.

The lower die having by this time been pushed forward to the return-point, it is again moved back by the downward movement of the levers  $E'$  and segment  $J''$ , as before described. At an opportune moment in the rearward movement of the die-bed the head  $D$  revolves, thereby bringing the creasing-die  $t$  into co-relation with the lower die, and which continues to revolve while the die is passing under it, thereby creasing and marking the nail-prints in the face of the shoe by a rolling pressing action.

The revolving movement of the head and die alluded to is accomplished by the segment  $F$  engaging the rack  $F''$ . The engagement of the two is effected by substantially the same means employed to engage them for the operation of the die  $n$ , viz., the spring  $j$  and a hook,  $H$ , each segment being alike furnished with a hook, as will be seen in Fig. 6, which, in their opportune co-operation with the spring  $j$ ,



causes a timely engagement of the segment with the rack  $F''$ , to produce a concertation of action of the revolving dies with the lower one for pressing the bevel on the inside of the shoe, and creasing and marking the nail-prints in the face thereof. The creasing-die having performed its duty on the shoe, the shoe is now to be removed from the die, to give place to another blank, which, by this time, has been placed in position by inserting a bar under the shear  $R$ , by which the blank is to be cut off, which, during the several movements of the machine, has been operated in due time for that purpose.

The removal of the shoe from the die is effected as follows: During the rearward movement of the die following the action of the creasing-die the arms  $y y$ , Fig. 3, are elevated from a horizontal position to that shown in Fig. 8, by means of the arm  $k'$ , engaging, at the proper time during the movements of the machine) the pin  $L$ . This elevation of the arms causes them to engage the ends of the slides  $C' D'$  during the rearward movement of the die-bed. Said slides by this contact with the arms are pushed in, thereby opening the die, as shown in Fig. 16. The die thus opened allows the end of the bar  $O'$ , Figs. 3 and 1, to spring forward between them and force the shoe from the die before the return of the die-bed. The die remains open to receive the bar or blank awaiting its return to be bent therein and by around the former  $f'$ , substantially in the same way as hereinbefore described, the operation of the machine being again wholly repeated.

It will be observed that the greatest efficient power of the lever or levers  $E'$  is during the time that the revolving dies and the bed-die are, respectively, in conjunction, in which event the sliding boxes  $F'$  of the cranks  $H'$  are nearest the end of the levers, as will be seen in Fig. 7, also in Fig. 18. The power thus applied to the end of the levers overcomes the increased resistance of the bed to move, caused by the increased pressure of the dies on the shoe being operated thereby.

The position of the sliding boxes, as shown in Fig. 6, is such as when the dies are not in conjunctive relation. Hence the weight of the die-bed and die is all that the lever or levers  $E'$  have to move, now, at their shortest leverage.

In the course of the movement of the machine, as the dies come together, pressing the shoe, their resistance to be moved is increased, at which time or times the lever-power is also increased by the outward movement of the sliding boxes toward the end of the lever. Therefore, a proportionate, steady, and efficient power is applied for operating the machine.

The peculiar construction of the levers  $E'$  is such as to cause a much quicker forward movement than a rearward one of the die-bed or carriage; hence the dies are brought sooner into operative relation than if the reciprocating

movement of the bed were performed in the same length of time. Therefore is increased the productive capacity of the machine.

A resume of the general movements of the machine is thus: At an opportune moment in the course of the operation of the machine the end of a bar of iron is pushed under the shear, across the machine, to a gage. By the shear a proper length for a shoe is cut off, and which now lies in front of the head  $e'$ , between it and the lower die, which now moves forward open to receive it. This movement of the die bends the blank around the toe of the former  $f'$  and against the sides of which it is now pressed by the closing together of the die, the die being carried forward by the levers  $E'$ , and closed by the slides  $C' D'$ . The die bed or carriage now moves back, and when at a certain point in its backward movement the revolving die  $n$  enters the lower or bed die, and presses the bevel on the shoe held therein, the rotation of the die  $n$  being effected by the segment  $G$  and rack  $F''$ . This pressing having been done, the lower die returns to the front, from whence it started, and from which it is again moved rearward by the segments  $J''$  and rack  $K'$ . At a certain point in the rearward movement of the die-bed the upper die  $t$  engages the lower die, and by a revolving pressing-action creases and forms the prints for the nail-holes in the face of the shoe. The shoe, on passing from under the upper die, is ejected from the die by the rod  $O'$ , which enters between the open die and forces the shoe therefrom, the die being opened for the release of the shoe by the slides  $C' D'$  in their contact with the arms  $y y$ , at this time elevated that they may engage the ends of the slide for the purpose aforesaid. The now empty die returns again to the front, and is closed by the contact of the ends of the slides with the end of the frame, thereby bending a blank around the former  $f'$ , previously cut from the bar, as above described, and which, in the same manner, is subjected to the action of the revolving dies, substantially as set forth, the various operations and movements of the machine all being timely and in order, for the accomplishment of the purposes described.

What I claim as my invention, and desire to secure by Letters Patent, is—

1. The lever or levers  $E'$ , having a segmental arm or arms,  $J''$ , in combination with the cranks  $H' H'$ , and die bed or carriage  $W$  for operating the same, substantially as herein described, and for the purpose set forth.

2. The segments  $F G$  and hooks  $H H$ , arranged to operate in combination with the rack  $F''$  and spring  $j$ , in the manner substantially as described, and for the purpose specified.

3. The intermittent revolving die-head  $D$ , having thereon dies  $t$  and  $n$ , in combination with the reciprocating bed-die consisting of sections  $A B'$ , slides  $C' D'$ , and devices for arresting the forward and backward move-

ments of the slides, substantially in the manner as described, and for the purpose specified.

4. The intermittingly-revolving die-head D, having thereon dies *t* and *n*, in combination with the notched wheel I, slide O, barrel N, and spring therein, pin *r*, and slide P, substantially in the manner as described, and for the purpose set forth.

5. In combination with the stay-wheel I and pin *r*, the vertical slide P, and wrist-pin *m* of the wheel J', operating substantially as described, and for the purpose set forth.

6. Arm or lever K', and arms *y y*, arranged to operate in combination with the wheel K and pin L, substantially as described, and for the purpose specified.

7. In combination with the vibratory arm or stem *d'*, the arm V', wheel K, pin M, and spring *w*, substantially as and for the purpose set forth.

8. The lever R', pin T', pins *i i*, and spring U', arranged to operate in combination with the head *e'* and die or former *f'*, substantially as described, and for the purpose specified.

9. The pendent vibratory arm *h*, having a hook, *g'*, spring *h'*, and rod *k*, in combination with the head *e*, and die or former *f'*, in the manner substantially as described, and for the purpose set forth.

10. The combination of the sliding carriage *b'*, spring *w*, and vibratory stem or arm *d'*, as and for the purpose set forth.

11. The sliding carriage *b'* and adjusting-rod *a''*, arranged to operate in relation to, and in combination with, the die-bed W, in the manner as described, and for the purpose set forth.

12. Arm or lever K', and arms *y y*, in combination with the divided die A B', slides C' D', and device for arresting the forward movement of said slides, in the manner substantially as described, and for the purpose specified.

MYRON BENJAMIN.

Witnesses:

J. H. BURRIDGE,  
R. SIMPSON.