

B. F. MANIER.  
RECLINING CHAIR.

No. 185,247.

Patented Dec. 12, 1876.

*Fig: 1.*

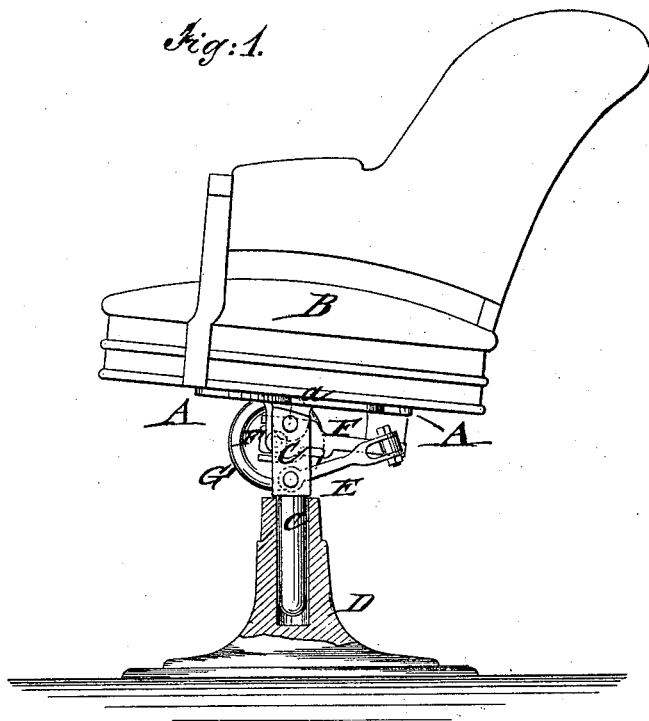

*Fig: 2.*

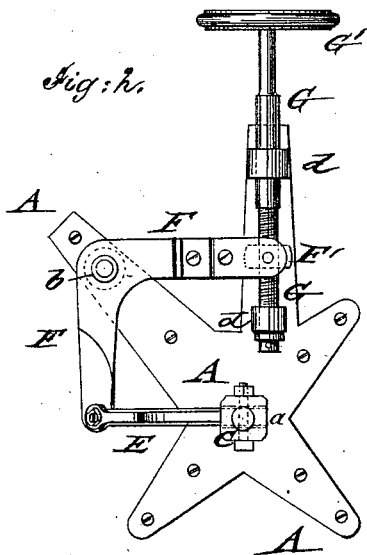

WITNESSES:

*Chas. Vista*  
*Alex. J. Roberts.*

INVENTOR:

*B. F. Manier*  
BY *Munn & Co*

ATTORNEYS.

# UNITED STATES PATENT OFFICE.

BENJAMIN F. MANIER, OF GREEN ISLAND, NEW YORK.

## IMPROVEMENT IN RECLINING-CHAIRS.

Specification forming part of Letters Patent No. 185,247, dated December 12, 1876; application filed October 30, 1875.

To all whom it may concern:

Be it known that I, BENJAMIN F. MANIER, of Green Island, in the county of Albany and State of New York, have invented a new and Improved Reclining-Chair, of which the following is a specification:

In the accompanying drawing, Figure 1 represents a side elevation of my improved reclining-chair, with socket-base in section; and Fig. 2 is a bottom view of the supporting-frame and adjusting mechanism of the chair.

Similar letters of reference indicate corresponding parts.

The object of my invention is to furnish for drawing-room cars, steamboats, office, and household use an improved reclining-chair, that affords a seat whose position can be regulated to any desired inclination by the occupant, and so made more comfortable than a rigid seat.

The invention consists of a supporting-frame, which is attached to the bottom of the chair, and pivoted to the forked spindle, revolving in a stationary socket-base. The bottom frame and chair are adjusted by the joint action of an arm pivoted to the spindle and to a bell-crank lever, that is fulcrumed to the bottom frame and operated by a hand-screw, which turns in bearings of the frame, and a swivel-nut of the forked end of the bell-crank lever.

In the drawing, A represents the supporting base-frame of the chair, which is made of suitable cast metal, and somewhat in the shape of a five-pointed star, of which two adjoining points are made of greater length than the remaining three. The frame A is rigidly screwed or otherwise attached to the bottom of the chair B, which is made of any suitable form and finish. Frame A is cast with a central lug, *a*, and pivoted by the same to the upper forked end of a spindle, C, which turns by its lower round end, in the customary manner, in a socket-base, D, applied stationary to the floor of the car or other place.

An arm, E, is pivoted at one end to the forked part of the spindle C, below the lug *a*, and at the outer end to one arm of a bell-crank lever, F, that is fulcrumed to a pin, *b*, at the end of one of the extended arms of

frame A. The opposite arm of bell-crank lever F is forked, and provided with a swivel-nut, F', through which a screw-bolt, G, supported in bearings *d* of the second extended arm of frame A, passes.

Screw-bolt G is operated by the occupant from the seat by means of a hand-wheel, G', at the end, so that the fulcrumed bell-crank lever may be carried to one side or the other, according as the chair is desired to be raised or lowered. The compound action of the bell-crank lever and of the pivoted connecting-arm E produces the adjustment of the chair to any inclination by swinging the bottom frame A on its pivot-point.

The operation of adjusting the seat to give it the proper inclination is performed by turning the screw-shaft, which will cause the end of the elbow-lever swiveled to the traversing screw to move in an inward direction, and, by reason of its pivotal connection with the seat-frame and the pivoted arm on the standard, it will move the seat-frame in a downward direction to give it the necessary degree of inclination.

The pivoted arm is an important element, for it will be perceived that when the elbow-lever is turned it will, by reason of its peculiar attachment, cause said pivoted arm to be carried in a downward direction for adjusting the seat. The chair is thereby set in very convenient manner into the exact position and inclination desired by the occupant; and the mechanism can be applied easily to chairs already in use.

Having thus described my invention, I claim as new and desire to secure by Letters Patent—

The combination of the chair-supporting base-frame, forked revolving spindle, pivoted connecting-arm, the fulcrumed bell-crank lever, and adjusting hand-screw, turning in a swivel-nut of the bell-crank lever, for the purpose of adjusting the chair to any angle of inclination from the seat, substantially in the manner and for the purpose set forth.

BENJAMIN F. MANIER.

Witnesses:

GEO. CONKEY,  
ARCHIE CULLEN.