

E. O. SCHARTAN.
CIGAR MACHINE.

No. 185,264.

Patented Dec. 12, 1876.

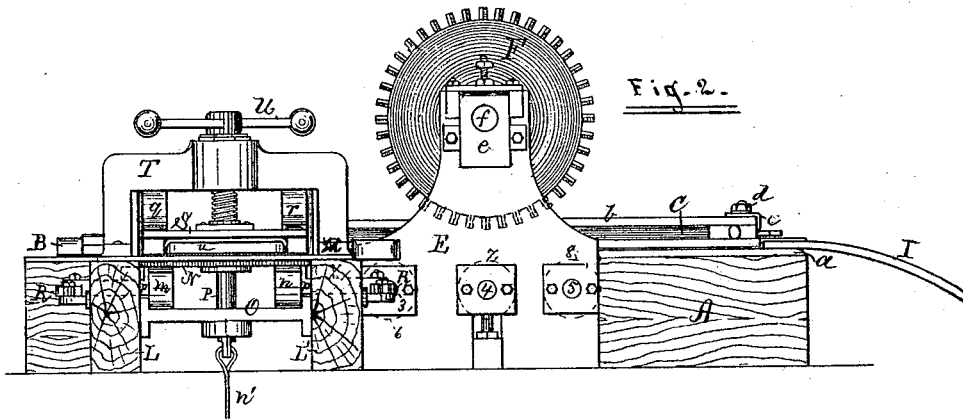
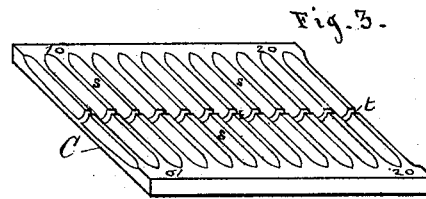
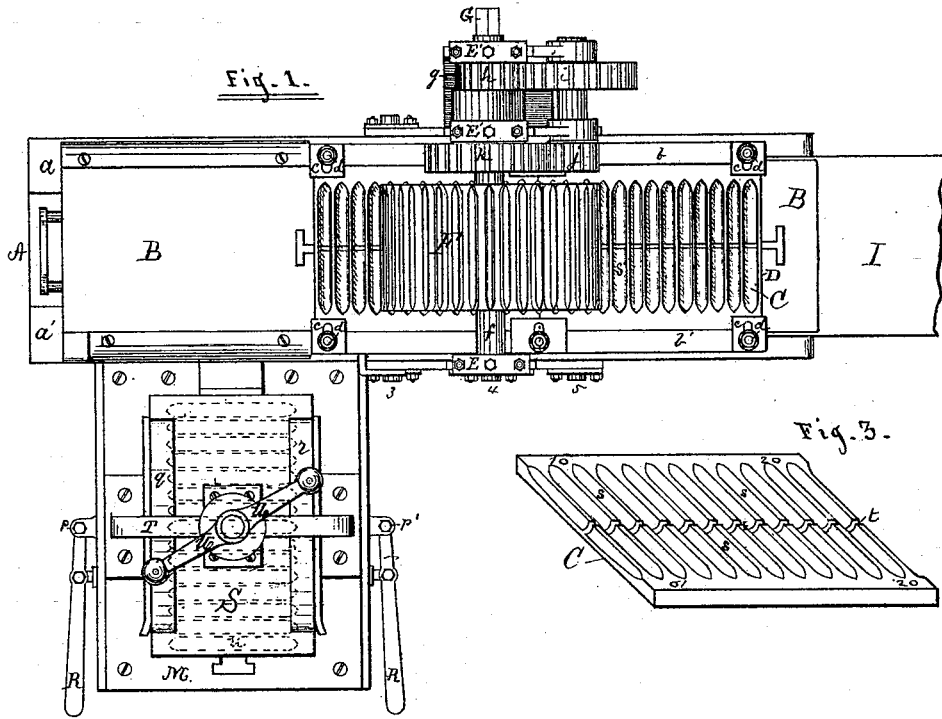

WITNESSES.

J. H. Hubbell
J. J. Roach.

INVENTOR.

E. O. Schartan
By H. N. Jenkins

ATTORNEY.

UNITED STATES PATENT OFFICE

EIBERT O. SCHARTAN, OF NEW ORLEANS, LOUISIANA.

IMPROVEMENT IN CIGAR-MACHINES.

Specification forming part of Letters Patent No. 185,264, dated December 12, 1876; application filed June 9, 1876.

To all whom it may concern:

Be it known that I, EIBERT OTTO SCHARTAN, a resident of the city of New Orleans and State of Louisiana, have invented a certain new and useful Improvement in Machines for Making Cigars; and I do hereby declare the following to be a full, clear, and correct description of the same, reference being had to the annexed drawing, making a part of this specification.

This invention relates to a machine for the manufacture of cigar fillings in longitudinal half-sections, the said sections to be afterward secured together by means of wrappers in the ordinary manner.

In order to enable others skilled in the art to which my invention appertains to make and use the same, I will now proceed to describe its construction and operation, referring to the annexed drawing, in which—

Figure 1 is a plan or top view, and Fig. 2 a side elevation, of my invention. Fig. 3 is a perspective view of one section of molds.

A is a frame or bed, the top of which is provided at each side and throughout its whole length with metallic ways *a a'*, on which is operated a sliding bed, B, provided with raised sides *b b'*, between which are placed, when the machine is to be operated, the cigar-molds C, having face-plates D. The under sides of the latter are provided with pins, which fit into orifices 1 2, that are formed in the top of the mold-plates, so as to hold the openings of the former directly over the recesses or molds of the latter. Two or more sets of molds may be placed upon the sliding bed, to which they are secured by means of locking-plates *c* and screws *d*. On each side of the frame A are securely bolted the stands E E', provided with journal-bearings *e*, in which operate the journals of the shaft *f*, and on which is keyed or otherwise secured a pressure-roller, F, across the circumference of which is constructed a series of projections for forcing the tobacco through the openings of the face-plates and into the molds, as the latter are moved back and forth.

Motion is imparted to the machine through a train of wheels, *g, h, i, j,* and *k*, the former keyed to a shaft, G, one end of which projects beyond the double stand E', in which it has

its bearings. The projecting end of the aforesaid shaft may be provided with a crank or pulley, according to the power to be applied for the operation of the machine. 3, 4, and 5 are shafts, each of which is provided with rollers, as at 6, 7, and 8, for relieving the ways from the extra pressure caused by the action of the roller F upon the tobacco. I is a piece of leather, or other pliable material, one end of which is secured to the traveler or sliding bed B. This piece of leather or apron is of the width of the sliding bed, so that it may cover that portion of the frame between the ways *a a'*, and prevent it from becoming filled with tobacco or dirt as the bed is being moved forward. After the tobacco has been thus pressed into the molds, the next step necessary is to remove the fillings without damage to the edges thereof.

To accomplish this desired result a screw-press of peculiar construction is connected to the above-described machinery. This press is secured to a side frame, composed of the projecting pieces L L', upon the top of which is secured a bed-plate, M, provided with a rectangular opening, which is at certain stages of the operation entirely closed by the lower platen N, the face of which is brought to a level with the top of the bed-plate, and above which it cannot rise because of its projecting flanges striking against the bottom of the said plate. The platen N is held in its uppermost position, when the machine is not in operation, by means of the springs *m n*, the centers of which rest upon and are secured to the cross brace or tie O, provided with an orifice, which serves as a guide for the standard P, to the lower end of which is attached a rod or cord, *n'*, by means of which the platen may be lowered whenever requisite. R R' are side levers for operating the locking-pins *p* on each side of the lower platen, and by means of which the said platen may be securely held in either its upper or lower position. Immediately above the platen just described, operated by means of a screw, is an upper platen or follower, S, the lower side of which is provided with projections or stamps, the configurations of which are similar to the openings in the face-plates C, but of a shade less in length and width, their object being, when

lowered, to pass through the aforesaid openings, pressing more evenly the tobacco in the molds, and trimming the ragged edges around the same. The screw of the upper platen passes up through the center of an arched beam, T, and its top end is provided with a lever similar to that of an ordinary letter-press, as shown at U. The said platen, like the lower one, is provided with springs *q r*, for the purpose of keeping it, when the machine is not in operation, in a given position.

The operation of my invention is as follows: The tobacco should be first dampened and prepared in the ordinary manner, after which it is spread, to a certain depth, over the face-plates of the molds. The machine is then put in motion, and, as the bed B moves back and forth, the tobacco is, by the projections of the wheel F, forced through the openings of the face-plates into the molds, in which it is, by the repeated action of the aforesaid wheel, pressed to the exact form of the molds. The machine is then stopped, and the molds, with their face-plates and contents, transferred to the hand-press, where they are in rapid succession operated upon as follows: The upper platen is first raised, so as to permit of one set of molds, with face-plates, being slipped over the bed-plate, and placed squarely upon the lower platen. The upper platen is next screwed down until its projections (shown in dotted lines at Fig. 1) pass through the face-plates, cutting the tobacco around the same, and forcing that which is in the molds more closely together.

In order to remove the fillings, which are by this time finished, the lower platen is, by means of the cord *n'*, pulled downwardly, and, inasmuch as the mold-plate is made somewhat smaller than the rectangular opening of the bed-plate, it naturally falls with the platen, and, as the face-plate is much larger than the said opening, it is, by the edges thereof, held on the top of the same. The lower platen is now locked in its downward position by means of the levers R, and the platen S, screwed to

its uppermost position, which admits of the face-plate being raised off the bed, and the molds with their contents being drawn off the lower platen, after which the fillings are severed at their centers by drawing a sharp knife through the groove *t* in the mold-plate. The divided sections are finally placed in pairs with their flat sides together, and wrapped by hand in the usual manner.

The making of cigar-fillings in longitudinal half-sections, as described, furnishes a vent through the center of the cigar, which renders the smoking of the same both easy and agreeable.

Having described my invention, and its mode of operation, what I claim as new, and desire to secure by Letters Patent, is—

1. In a cigar-machine, the combination of the frame A, provided with ways *a a'*, sliding bed B, provided with raised sides *b b'*, mold C, face-plate D, shaft *f*, and pressure-roller F, operating substantially as described.

2. In a cigar-machine, the combination of the frame L L', bed-plate M, constructed as described, platens N S, the latter provided with projections, mold C, and face-plate D, substantially as described.

3. In a cigar-machine, the combination of the frame L L', bed-plate M, platens N S, press U, springs *m n q r*, rope *n'*, mold C, and face-plate D, substantially as described.

4. In a cigar-machine, the combination of the frame L L', bed-plate M, platens N S, press U, springs *m n q r*, rope *n'*, levers R R', pins *p*, mold C, and face-plate D, substantially as described.

5. The cigar-mold plate C, provided with a series of molds, *s s*, of the form shown, and a longitudinal groove, *t*, extending across its face, substantially as described.

In witness whereof I have hereunto affixed my hand.

EIBERT O. SCHARTAN.

Witnesses:

H. N. JENKINS,
J. C. HUBBELL.