

M. BOURKE.
BOAT-LAUNCHING APPARATUS.

No. 185,283.

Patented Dec. 12, 1876.

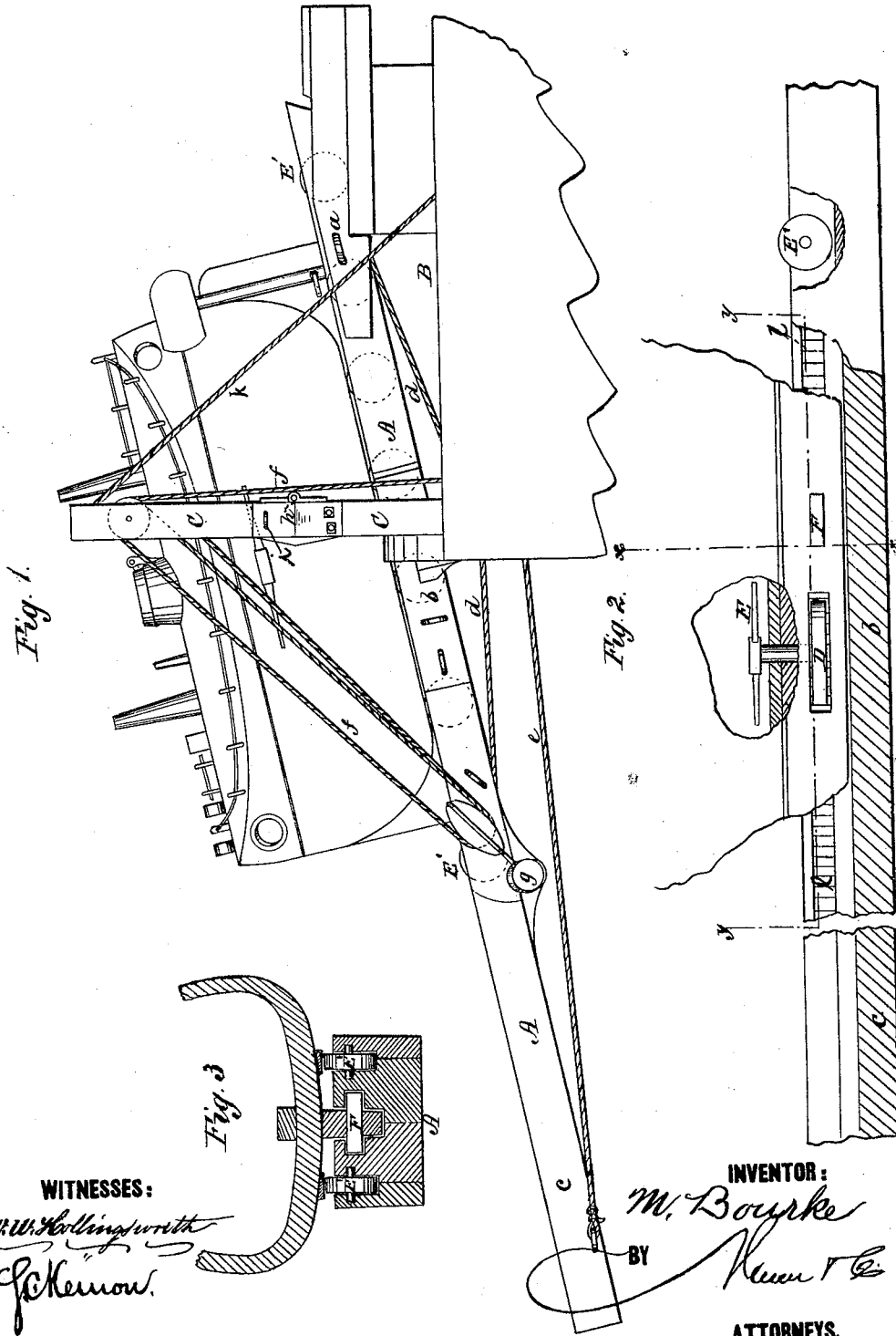

WITNESSES:
W. W. Hollingworth
J. C. Kemmer.

INVENTOR:
M. Bourke
BY *Kenn & Co.*
ATTORNEYS.

M. BOURKE.

BOAT-LAUNCHING APPARATUS.

No. 185,283.

Patented Dec. 12, 1876.

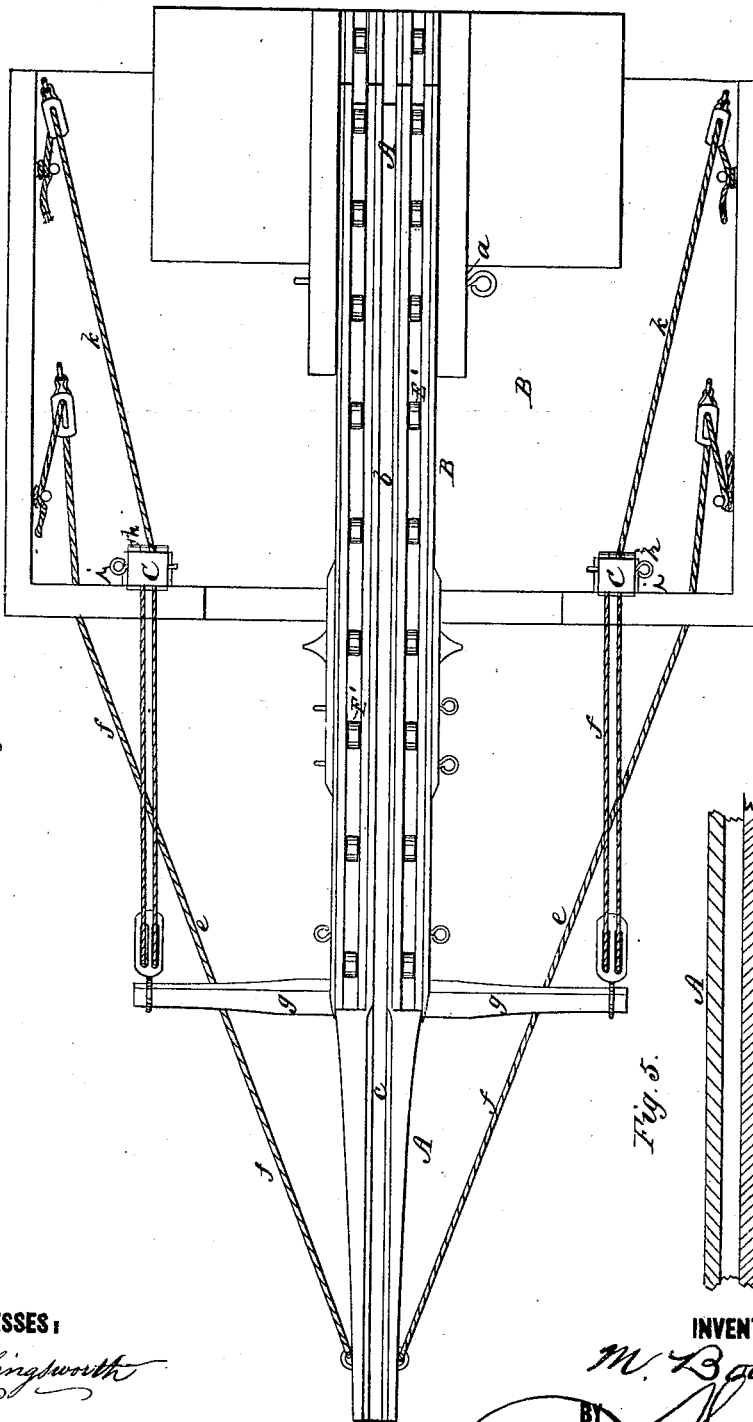

Fig. 4.

Fig. 5.

WITNESSES:

W. W. Hollingsworth
J. K. Lemon

INVENTOR:

M. Bourke
 BY *Keen & Co.*

ATTORNEYS.

UNITED STATES PATENT OFFICE.

MARTIN BOURKE, OF MINERAL RIDGE, OHIO, ASSIGNOR TO BOURKE,
WISE & CO.

IMPROVEMENT IN BOAT-LAUNCHING APPARATUS.

Specification forming part of Letters Patent No. **185,283**, dated December 12, 1876; application filed
June 23, 1876.

To all whom it may concern :

Be it known that I, MARTIN BOURKE, of Mineral Ridge, in the county of Trumbull and State of Ohio, have invented a new and Improved Launching Apparatus; and I do hereby declare that the following is a full, clear, and exact description of the same.

The invention has for its object to enable life and other boats to be launched from the deck of a vessel with safety and dispatch.

The invention consists of ways which are pivoted to the deck in such manner that the outer end, which projects beyond the side of the vessel, may be raised or lowered by suitable tackle, as required by size of the vessel, or the height of the deck above the water. The sides of the grooves in the ways are notched or provided with ratchet-teeth, and with these a pawl attached to the keel of the boat engages in such manner as to hold the boat stationary on the ways until ready to be launched. Such pawl is also constructed in such form as adapts it to act as a brake when the boat is descending the ways. The ways are made in sections, to adapt them to be stowed in small space.

In the accompanying drawings, forming part of this specification, Figure 1 is a side elevation of my apparatus, with a boat arranged therein in readiness for launching. Fig. 2 is a longitudinal section of a fragment of the ways, and a fragment of a boat locked thereto. Fig. 3 is a cross-section on line *x x* of Fig. 2. Fig. 4 is a plan view of the launching apparatus proper. Fig. 5 is a detail horizontal section, taken on line *y y*, Fig. 2.

The ways A are pivoted to any suitable portion of the deck B, as at *a*, and formed in sections *b c*, which are connected by pins or bolts, and thus made detachable, one from the other. The ways are likewise braced by bottom and side stays *d e*, to give them the requisite strength and firmness to support and properly launch a boat filled with people. The outer end of the ways A is raised and lowered, and also supported in any desired position corresponding to the height of the deck above the water, by means of tackle *f*, which connects with a cross-bar, *g*, attached to the front section *c*. The rope constituting

part of said tackle passes through the top of posts C, which rise vertically from the side of the vessel. These posts are jointed at *h*, to adapt their top portions to fold down alongside the lower portions, and thus be out of the way when not required for use. The said top portions are held erect by pins *i*, inserted through side plates or pieces attached to the lower portions, so that the posts are as firm as if made in one piece. Straps *k* extend backward from the top of the posts, as shown.

The boat will, in practice, be supported upon a grooved turn-table, capstan, or other equivalent device, whereby it may be turned around to enter the ways A preparatory to the launch. This turn-table or capstan may be located upon deck wherever convenient, and the boat remain attached to it while not in use. The groove in the ways A is undercut, and ratchet-teeth C formed on the parallel sides thereof, as shown. These teeth run in opposite directions, to adapt them to engage simultaneously with the pawl or locking-lever D, which is pivoted to or in the keel of the boat, and operated by a lever, E, attached to the stem extending up through the floor of the boat.

When the pawl is turned parallel with the keel, as shown, it is freed from the ratchet-teeth *l*, and the boat is free to move on the ways A; but when turned across or at an angle to the keel, as shown in Fig. 5, it locks the boat to the ways by its respective ends engaging the reversed ratchet-teeth. The pawl is also adapted to another function—to wit, that of a brake. It is so adapted by rounding or cutting away two of its diagonally opposite corners.

When the device is turned at an angle to the keel, as shown in dotted lines, Fig. 5—that is to say, the reverse of the position required to effect the lock with the ratchet-teeth, as above described—the rounded corners come in contact with the sides of the groove in ways A, and by their friction, caused by force applied to the lever E, operate to brake the boat as it descends the ways into the water. The lever E enables the device to be readily brought into action, either as a pawl or brake, by the occupants of the boat. For convenience of

such operation, cords may be attached to the ends of the lever, as to a tiller. A pawl may be suitably applied to hold the device engaged with the ratchet-teeth, and the device may thus suffice, under ordinary circumstances, to hold the boat fast upon the ways without lashing.

The ways are provided at intervals of space with rollers E', to relieve the friction with the boat as it moves over them, and plates or bars may be attached to the underside of the boat, alongside the keel, with which the wheels may work in contact. The boat is held to the ways by means of lugs or a short cross-bar, F, which passes through the keel, its ends fitting in the sides of the groove. At the outer end c of the ways the groove is not undercut, so that the cross-bar F offers no obstruction to clearance of the boat from that portion of the ways.

To launch a boat, the sections of the ways are connected together, as shown in Figs. 1 and 4, the hinged portion of posts elevated to a vertical position, and the tackle f manipulated to support the ways. The boat is then turned, upon the capstan or turntable, athwart the vessel, into position to enter the first section of ways A, to which it is then locked by the pawl D, and the ways lowered into position, Fig. 1, to launch the boat. The passengers and crew then enter the boat, the hatch is secured, and the tackle f loosened to lower the ways A, when the pawl D is released from the ratchet-

teeth l, and the boat at once glides into the water, being thus safely launched at such distance from the side of the vessel as to avoid the danger of injury by contact therewith.

I do not restrict the application of my invention to decks of vessels, since it may in some cases be advantageously employed to launch a boat from shore.

What I claim is—

1. In a boat-launching apparatus, the ways A, provided with friction-rollers, as and for the purpose specified.

2. In a boat-launching apparatus, the ways A, provided with a groove having notches or ratchet-teeth formed on one or both of its sides, for engagement of a pawl attached to the boat, as shown and described.

3. In a boat-launching apparatus, the ways A, having an undercut groove to receive a cross-bar or lug attached to the keel of the boat, as shown and described, for the purpose specified.

4. In a boat-launching apparatus, pivoted ways A and tackle for raising and lowering the same, combined as shown and described.

5. In a boat-launching apparatus, the jointed vertical posts, as shown and described.

6. In a boat-launching apparatus, the pawl attached to the boat, in combination with the notched ways, as shown and described.

MARTIN BOURKE.

Witnesses:

A. W. HART,
WM. H. HADAWAY.