

C. FLESCH.  
 ATTACHING HUBS TO AXLES.  
 Patented Dec. 12, 1876.

No. 185,309.

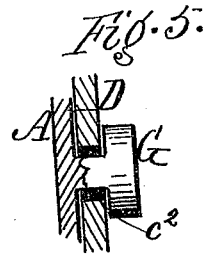
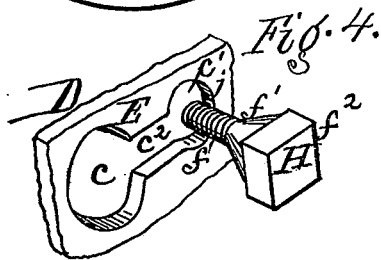
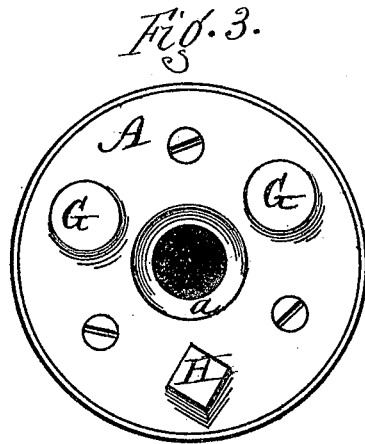
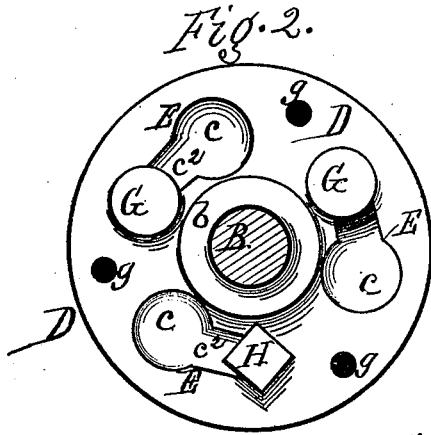
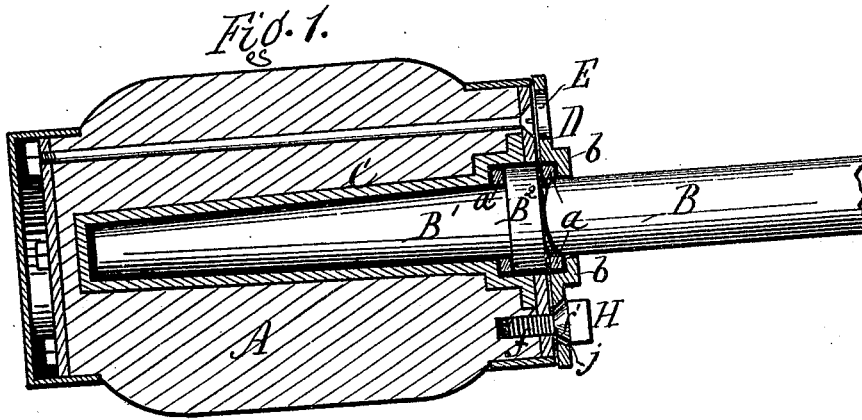

Witnesses.  
 Jacob Spahr  
 Edwin Scott.

Inventor.  
 Charles Flesch,  
 per R. F. Osgood,  
 Atty.

# UNITED STATES PATENT OFFICE

CHARLES FLESCH, OF ROCHESTER, NEW YORK, ASSIGNOR OF ONE-HALF  
OF HIS RIGHT TO JOSEPH RIPPIN, OF SAME PLACE.

## IMPROVEMENT IN ATTACHING HUBS TO AXLES.

Specification forming part of Letters Patent No. 155,309, dated December 12, 1876; application filed  
October 7, 1876.

*To all whom it may concern:*

Be it known that I, CHARLES FLESCH, of the city of Rochester, in the county of Monroe and State of New York, have invented a certain new and useful Improvement in Carriage-Wheels; and I do hereby declare that the following is a full, clear, and exact description of the construction and operation of the same, reference being had to the accompanying drawings, in which—

Figure 1 is a section of a carriage-hub, showing my improvement. Fig. 2 is an end view of the same. Fig. 3 is a similar view with the locking-disk removed from place. Figs. 4 and 5 are detail views, showing the means for securing the locking-disk.

My improvement relates to means for securing the hub to the axle at the inner end of the hub, thereby leaving the outer end of the hub closed. Devices for this purpose are already known; hence I do not claim such, broadly.

My invention consists of a locking-disk at the inner end of the hub, provided with slots having enlarged sockets at their ends, in combination with T-headed studs and a conical clamping-screw, as and for the purposes hereinafter more fully described.

A is the hub, the outer end of which is closed. B is the axle. B<sup>1</sup> is its journal, and B<sup>2</sup> the collar. C is the box in which the journal rests, being closed at its outer end. *a a* are leather or other packing-rings, resting on opposite sides of the collar B<sup>2</sup>. Thus far the wheel is of ordinary construction. D is the locking-disk. It is a thin plate of metal, which rests closely around the axle, against the collar, and abuts against the inner end of the hub. It has a central offset, *b*, which incloses the packing-ring *a*. In the body of the disk are three or more concentric slots, E E E. Each of these slots has an enlarged opening, *c*, at one end, a smaller opening, *c*<sup>1</sup>, at the other end, and a narrow neck, *c*<sup>2</sup>, connecting the two openings. This is clearly shown in Figs. 2 and 4. The smaller opening *c*<sup>1</sup> is of somewhat larger diameter than the neck, and its edges are beveled outward to receive the conical tightening-screw, as shown at *j*, Figs. 1 and 4. G G are T-heads, permanently at-

tached to the inner end of the hub, and standing outward therefrom. They are of a diameter smaller than the large openings *c c* of the locking-disk, but larger than the small openings *c*<sup>1</sup> *c*<sup>1</sup> or the necks *c*<sup>2</sup>, so that when the locking-disk is inserted over the studs and turned around, said locking-disk will be held by the T-heads, as shown in Fig. 5. H is a screw, which passes through the third slot of the locking-disk, and enters the end of the hub. It consists of a threaded end, *f*, which holds in the hub a conical body, *f*<sup>1</sup>, which rests in the beveled smaller opening *c*<sup>1</sup> of the disk, and a square head, *f*<sup>2</sup>, by which the screw is turned. The large openings *c c* are placed over the T-headed studs G G, and the disk is then turned, bringing the necks *c*<sup>2</sup> *c*<sup>2</sup> beneath the said T-heads, which holds the hub fast to the disk. The screw H is then turned down in the small opening *c*<sup>1</sup>, so that the cone *f*<sup>1</sup> fits closely in the beveled surface *j*, which holds the parts in place. The conical screw performs a double function: first, by resting in the opening *c*<sup>1</sup>, (which is larger than the neck *c*<sup>2</sup>;) it keeps the locking-disk in place, and prevents it from turning back; second, the cone sides fitting the corresponding beveled sides of the opening, it binds the disk down close and hard against the end of the hub. The disk being close-fitting under the T-heads, this binding action of the screw makes a close fit of the whole disk to the hub, so that no loose action or rattling can occur, which is a matter of much importance. The two parts are joined together as one fixture.

Much difficulty has heretofore been experienced in so securing the parts as to prevent looseness and rattling, as very great strain comes at this point. The single conical screw, fitting in its corresponding beveled seat, in connection with the T-heads, obviates all difficulty of the kind.

To remove the wheel from the axle, the screw is simply turned back one or two turns, which releases the disk. The latter can then be turned so as to remove it from the T-heads, which frees the hub from the axle.

*g g* are holes near the edge of the disk, in which to insert the point or pin of a wrench, to turn the disk if it should stick.

Having thus described my invention, I do not claim, broadly, a slotted collar held by screws; but

What I claim as new is—

In a carriage-wheel, the locking-disk D, provided with slots E E E, having the enlarged sockets *e* at one end, and the smaller sockets *e'* at the other, in combination with fixed T-headed studs G G, fitting in two of the slots, and the conical screw H, fitting in the third,

said screw resting in a beveled seat of the smaller socket, as and for the purpose specified.

In witness whereof I have hereunto signed my name in the presence of two subscribing witnesses.

CHARLES FLESCH.

Witnesses:

R. F. OSGOOD,  
EDWIN SCOTT.