

H. SCHMIDT & J. DIXON.
 BOTTLE WASHING-MACHINE.

No. 185,356.

Patented Dec. 12, 1876.

Fig. 1.

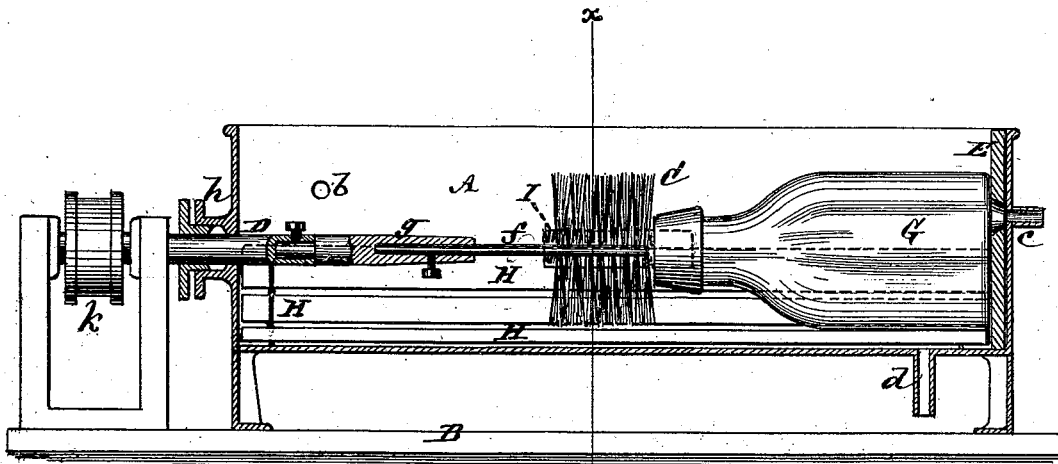
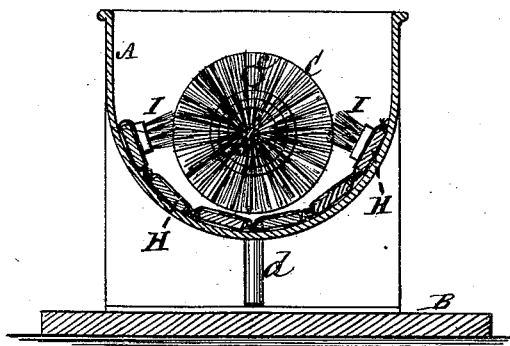

Fig. 2.



Witnesses.
 John Brecker.
 Geo. Haynes

Henry Schmidt.
 Joseph Dixon
 by their Attorneys
 Brown & Allen.

UNITED STATES PATENT OFFICE

HENRY SCHMIDT AND JOSEPH DIXON, OF MORRISANIA, NEW YORK, N. Y.

IMPROVEMENT IN BOTTLE-WASHING MACHINES.

Specification forming part of Letters Patent No. **185,356**, dated December 12, 1876; application filed October 19, 1876.

To all whom it may concern:

Be it known that we, HENRY SCHMIDT and JOSEPH DIXON, both of Morrisania, in the city, county, and State of New York, have invented certain new and useful Improvements in Machines for Washing and Cleaning Bottles, Jars, and other like vessels; and we do hereby declare that the following is a full, clear, and exact description of the same, reference being had to the accompanying drawing, which forms part of this specification.

This invention more especially relates to machines for washing and cleaning simultaneously both the insides and outsides of bottles, jars, and other like vessels; and consists in various combinations of parts or devices for performing such work with efficiency and dispatch, the same including an elongated trough, a rotating mandrel arranged to project only a limited distance within said trough, and carrying a brush for cleaning the interior of the bottle or vessel under operation, and one or more suitably-arranged brushes for cleaning the outside of said bottle or vessel; also, a removable flexible cradle forming a carrier for said outside cleaning-brushes, and means for preventing the breakage of the bottle or vessel in introducing and removing it from the machine.

Figure 1 represents a vertical longitudinal section of a bottle-washing machine, constructed in accordance with my invention; and Fig. 2 a transverse vertical section thereof on the line *x x*.

A is a water-trough, arranged horizontally thereabout on a table or stand, of which B is the top. This trough A is an elongated one, that is equal to about or more than twice the length of the longest bottle to be cleaned by the machine, and is preferably of circular form at its bottom in a transverse direction. Water may be supplied to the trough by an inlet, *b*, and the same be allowed to escape by a waste-pipe, *c*, whereby a fresh supply of water is constantly furnished to the trough, which latter may be emptied when required by allowing the water to be discharged through a blow-off pipe, *d*. C is a revolving brush used to clean the inside of the bottle, jar, or vessel. This brush, which may be of any suitable flexible material, is carried so that it can

be readily removed and replaced by another, if desired, the same having its shank *f* secured by set-screw, within a brush-holding shank, *g*, which in its turn is secured by set-screw within the inner end of the mandrel D by which the brush C is rotated. Said mandrel D is entered through a stuffing-box, *h*, at one end of the trough, and may be driven by a pulley, *k*, and belt from any suitable motion below the table or otherwise. At the opposite end of the trough to that through which the rotating mandrel is entered is an internally-arranged cushion, E, of india-rubber or other suitable soft material for the bottle G being cleaned to strike against when drawing it back from off the brush C, thus preventing the breaking of the bottle. Arranged freely within the trough and along it is a jointed or flexible stationary cradle, H, carrying one, two or more brushes, I, for cleansing the outside of the bottle while its inside is being cleaned by the revolving brush C. By means of the flexible and removable cradle, H, the brushes I, which are carried by it, may readily be entered within the trough and removed from it, as required, whereby increased facility is afforded for cleaning said brushes or for substituting others attached to corresponding flexible cradles or carriers, and adapted to operate on bottles of different size or diameter. Said cradle, also, which is mainly composed of wood or other soft material, protects the bottle from coming in contact with the hard-metal bottom of the trough when introducing it to or drawing it from the brushes, and consequently reduces the liability to breakage of the bottle.

The operation is as follows: Water is let into the trough A, and the brush C caused to revolve. The bottle G is then introduced within the trough at the cushioned end of the latter, as shown in Fig. 1, and is pressed against the brush C, which enters the neck of the bottle, and ultimately is worked wholly within the bottle and throughout its length by continuing to press the bottle up over said brush. While this is being done, the bottle G is allowed to revolve once or oftener, in order that the brushes I may clean the outside of the bottle as well. The bottle is then drawn back from off the brush C till its bot-

tom end strikes the cushion E, when it will be found thoroughly cleaned both inside and outside.

The same machine may be used for cleansing various descriptions and sizes of bottles, jars, and other like vessels.

I claim—

1. The combination of the elongated trough A, the revolving mandrel D, projecting within the one end of said trough, and having a brush, C, which rotates in concert with the mandrel, and one or more brushes, I, arranged within the trough, and in relation with the rotating brush C, substantially as and for the purposes specified.

2. The combination of the flexible and removable cradle H, having one or more attached brushes, I, the elongated trough A, and the rotating brush C, essentially as described.

3. The combination of the pad or cushion E at one end of the elongated trough A, and the revolving mandrel D at the opposite end of said trough, and the brush C carried by said mandrel, substantially as specified.

HENRY SCHMIDT.
JOSEPH DIXON.

Witnesses:

HENRY T. BROWN,
MICHAEL RYAN.