

J. R. THOMAS.
PLANING-MACHINE.

No. 185,364.

Patented Dec. 12, 1876.

Fig. 1.

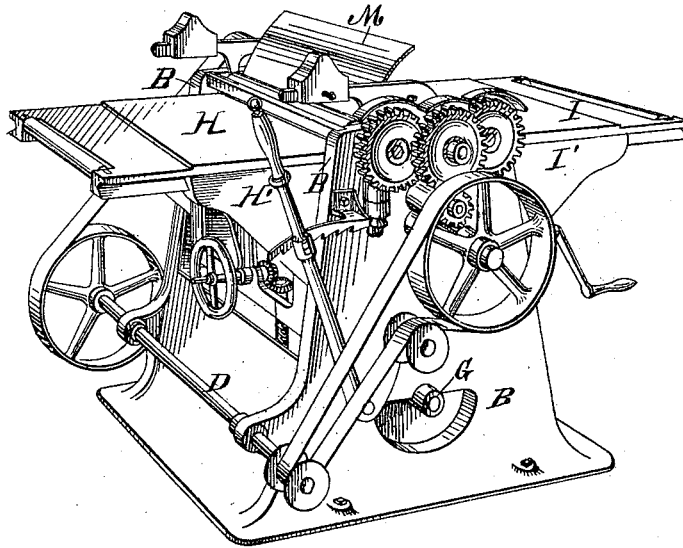
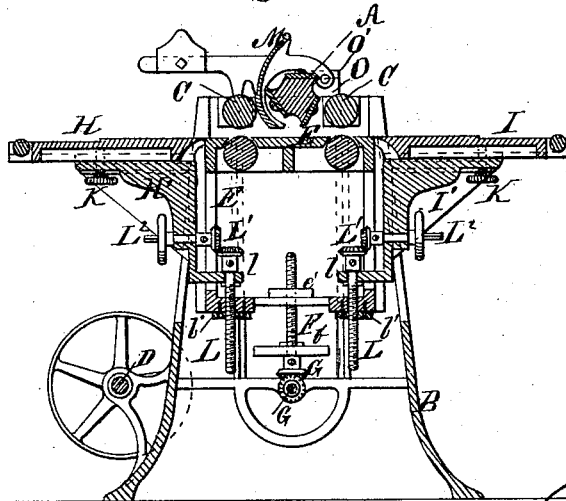

Fig. 2.



Witnesses.
L. Van Riewick.
M. Eils.

John R. Thomas
Inventor.
by *W. E. Eils.*
his Atty.

J. R. THOMAS.
PLANING-MACHINE.

No. 185,364.

Patented Dec. 12, 1876.

Fig. 3.

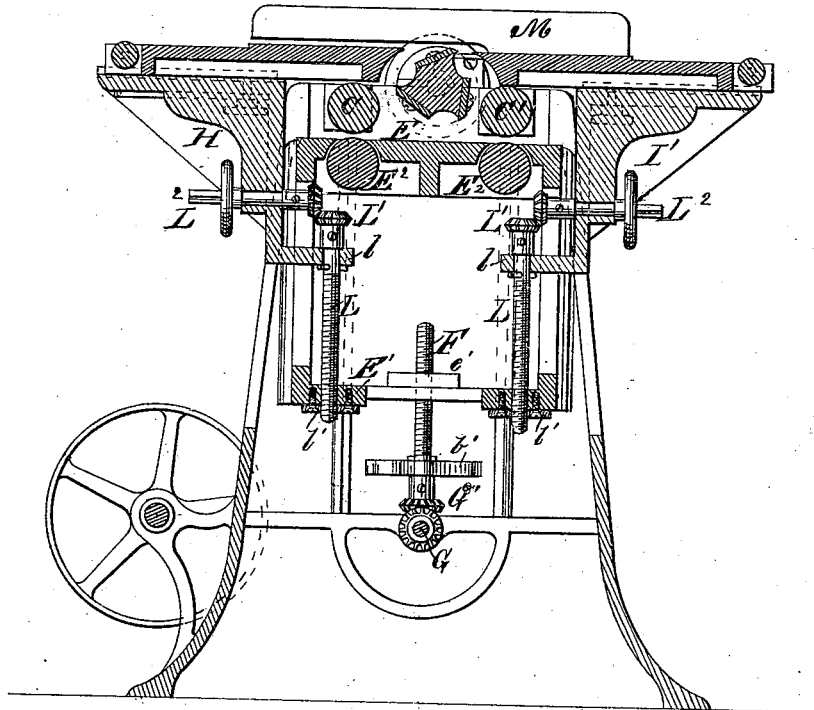

Witnesses:
L. Van Rinswick
m. Cils

John R. Thomas
 Inventor.
 by *P. J. Cils*
 his Atty

UNITED STATES PATENT OFFICE.

JOHN R. THOMAS, OF CINCINNATI, OHIO, ASSIGNOR TO J. A. FAY & CO.,
OF SAME PLACE.

IMPROVEMENT IN PLANING-MACHINES.

Specification forming part of Letters Patent No. 185,364, dated December 12, 1876; application filed August 19, 1876.

To all whom it may concern:

Be it known that I, JOHN R. THOMAS, of Cincinnati, in the county of Hamilton and State of Ohio, have invented certain Improvements in Planing-Machines, of which the following is a specification:

This invention relates to surface-planers, so adapted that stuff may be planed on them by passing it either over or under the cutter-head.

My improvement consists in arranging a short table underneath the cutter-head, and combining therewith two other tables, which are adapted, by suitable adjustments, to assume the same level as the short table, and thus serve as extensions thereof, in which case the machine is in condition to plane by passing the stuff under the cutter-head, or to be set in proper relation to the cutter-head, and act as the supporting-tables for the stuff when it is to be planed by passing it over the cutter-head.

In the annexed drawings, Figure 1 is a perspective view of my improved surface-planer as it appears when arranged for planing below the cutter-head. Fig. 2 is a vertical longitudinal section of the machine arranged as in Fig. 1. Fig. 3 is a vertical longitudinal section thereof, showing the adjustment of the tables for planing, over the cutter-head. Fig. 4 is a horizontal section. Figs. 5, 6, and 7 are detail views.

The same letters of reference are used in all the figures in the designation of identical parts.

The construction of the particular machine selected as an illustration of the embodiment of my invention will be readily understood from the following description and the drawings therein referred to.

The journals of the cutter-head A turn in suitable bearings, centrally located on the top of the respective sides B' B' of the stand or frame B. Feed-rolls C and C' are placed at opposite sides of the cutter-head, the journals of which rolls turn in boxes elastically seated, and project at one end to receive spur-wheels c and c', which may be driven from the main shaft D through the medium of such gearing, as shown in Fig. 1, or by any other preferred

means. The cutter-head is also driven from the main shaft A by belt-gearing, as shown.

E refers to the short table underneath the cutter-head. It forms the top of a frame-work, E¹, provided with vertical rails e e on the sides opposed to the sides B' B' of the stand, which rails are snugly fitted to slide on corresponding ways b b on the stand. This table E is supported adjustably on vertical screw-spindles F and F', which are mounted in fixed brackets b' b' on opposite sides of the stand, and engage nuts e' e', fixed to or formed in flanges on the bottom of the frame-work E¹ of the table. The screw-spindles are operated, for the purpose of adjusting the height of table E with reference to the cutter-head, by a cross-shaft, G, and intermediate bevel-gearings G' G', the cross-shaft having its bearings in the stand, through which it projects at one end to receive a hand-wheel or winch, by which to turn it. Rollers E² E², constituting counters to the feed-rolls C C', are arranged in slots in table E, as clearly shown in Figs. 2 and 3.

H and I are two tables, connected with and supported on vertically-adjustable brackets H' and I', respectively, on opposite sides of the cutter-head. Both these tables are constructed and arranged precisely alike. Each has dovetailed rails on its under side, fitting correspondingly-dovetailed slideways on the upper side of the horizontal portion of its respective bracket, as shown in Fig. 5, and each is secured to its bracket by a clamping-screw, K, which passes through an elongated slot, k, in the bracket, into a tap, k', on the under side of the table, the slot k admitting of any required extent of adjustment of the table toward and from the cutter-head in a horizontal direction.

The brackets are, in this instance, carried on the frame-work E¹ of table E, engaging, as best seen in Fig. 4, with dovetailed rails the vertical dovetailed slideways on said frame. Each bracket is supported by a vertical screw-spindle, L, which turns in a bearing in lug l of the bracket, and engages a nut, l', secured to or formed in the frame-work E¹. Each screw-spindle L is operated by an independent mechanism, composed of bevel-gearing L¹ and

short shaft L^2 , supported in a bearing of the bracket, and protruding sufficiently for the application of a hand-wheel or winch, or both. Anti-friction rollers are arranged in the outer ends of the tables H and I, the upper surface of which is preferably offsetted, as shown.

It should be observed that the size of the feed-rolls C and C' is kept within such limits that the tables H and I can move over them without interference in the act of adjusting them to position as the supporting-table for stuff to be planed by passing it over the cutter-head. M refers to a hood and chip-breaker, which is used only when the stuff is planed below the cutter-head; and N, to a guide or fence, which comes into requisition in doing certain work, when the stuff is planed by passing it over the cutter-head. Both the fence and the combined hood and chip-breaker may be of any preferred construction suitable for use on this machine, and both must be arranged so that they can be readily detached. The journals of the chip-breaker are, to this end, adapted to bearings O, (see Fig. 7,) which are open on top, and are provided each with a turn-button, O', to be turned over the journals of the chip-breaker when applied, and prevent it from becoming detached accidentally while in use.

It will be readily understood that the vertical and horizontal adjustability of the tables H and I admits of arranging them readily, either on a level with the short table E, as shown in Figs. 1 and 2, to serve as extensions of said table, or in planes nearly on a level with the upper side of the cutter-head, to serve as independent tables, in the manner shown in Fig. 3. The independent adjustability of the tables H and I being preserved, they may, of course, be set in different planes, as required, when the machine is used, as shown in Fig. 3.

It is, of course, necessary that the cutter-head and the table E be adjustable, one with reference to the other; but I wish it to be distinctly understood that my invention, as here-

inbefore described, is not limited to a structure in which the table E is adjustable with reference to the cutter-head, since the cutter-head may be mounted adjustably and the table E be fixed without departing from the principle of my invention. It should also be clearly understood that the manner of mounting the several tables, and the specific means of adjustment described, are not matters of essence as regards my invention, broadly considered.

What I claim as my invention, and desire to secure by Letters Patent, is—

1. The combination, substantially as specified, of the cutter-head, the short table E underneath thereof, and the tables which serve as extensions of the short table when the stuff is fed under the cutter-head, and as independent tables when the stuff is fed over the cutter-head.

2. The combination, substantially as specified, of the vertically-adjustable short table E underneath the cutter-head, and the tables H and I, connected with said short table, but also vertically adjustable with respect thereto.

3. The combination, substantially as specified, of the vertically-adjustable short table E underneath the cutter-head, and the tables H and I, connected with said short table, but also both vertically and horizontally adjustable with respect thereto.

4. The combination, substantially as specified, of the cutter-head, the short table E underneath thereof, the feed-rolls, and the tables H and I, which are both vertically and horizontally adjustable with respect to the other mechanical elements enumerated in this claim.

In testimony whereof I have signed my name to the foregoing specification in the presence of two subscribing witnesses.

JOHN R. THOMAS.

Witnesses:

W. H. DOANE,
G. B. LESH.