

T. A. MACAULAY.
SEWING-MACHINE.

No. 185,399.

Patented Dec. 19, 1876.

Fig 1.

Plate I. Fig 2.

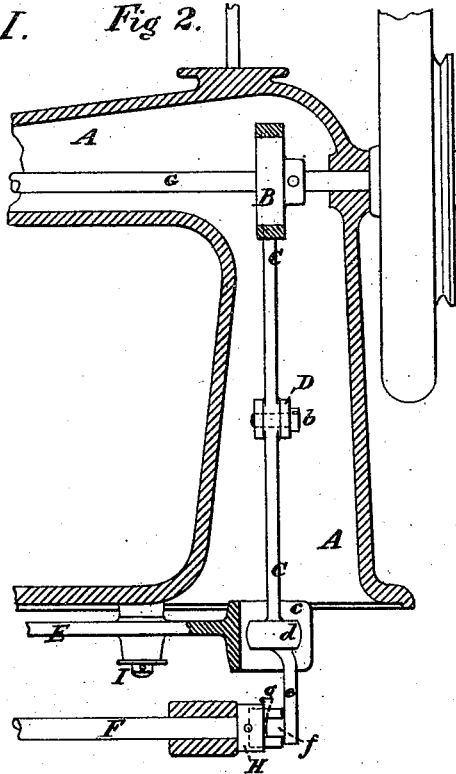
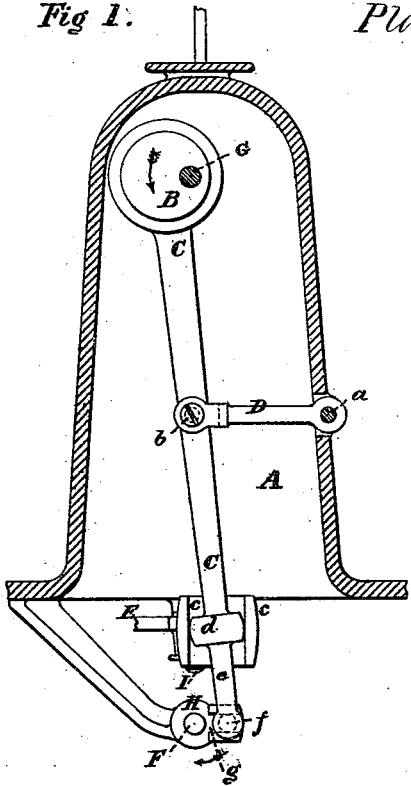

Fig 3.

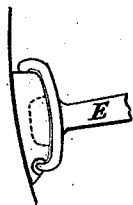
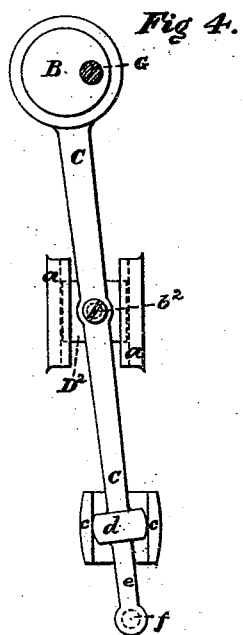
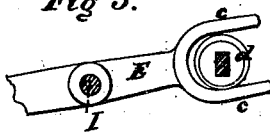

Fig 3.



Witnesses.

Walter W. Scott
Hugh, battery

Inventor.

T. A. Macaulay

T. A. MACAULAY.
SEWING MACHINE.

No. 185,399.

Patented Dec. 19, 1876.

Fig. 8.

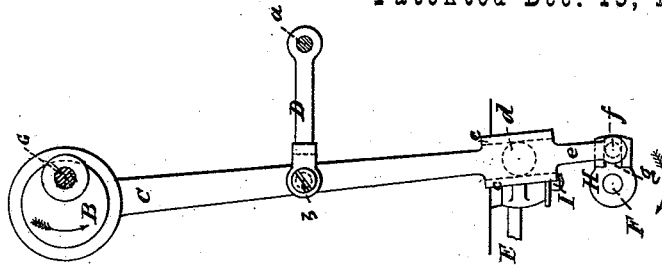

Fig. 7.

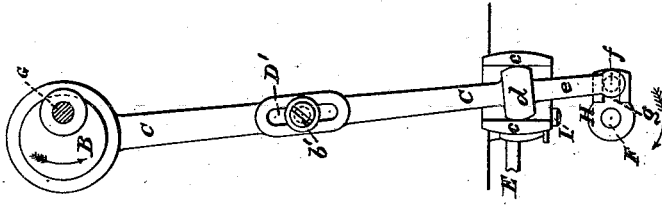

Fig. 6.

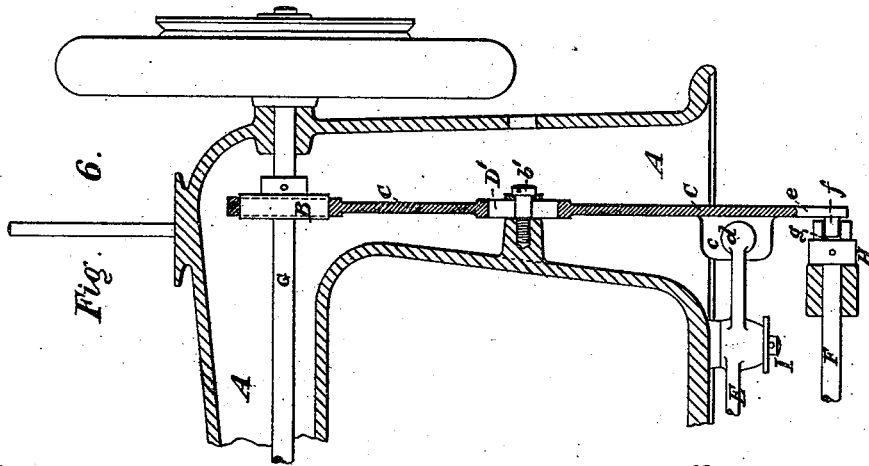
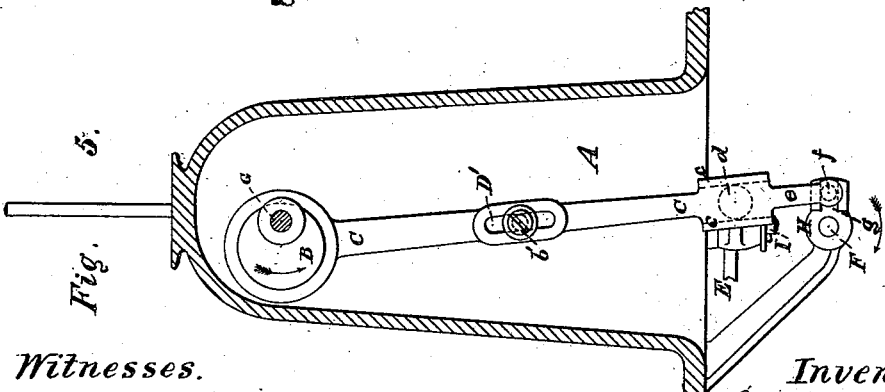

Fig. 5.



Witnesses.

Walter H. Scott
Hugh Kallary

Inventor.

T. A. Macaulay

UNITED STATES PATENT OFFICE.

THOMAS A. MACAULAY, OF NEW YORK, N. Y.

IMPROVEMENT IN SEWING-MACHINES.

Specification forming part of Letters Patent No. **185,399**, dated December 19, 1876; application filed October 13, 1876.

To all whom it may concern:

Be it known that I, THOMAS A. MACAULAY, of the city, county, and State of New York, have invented certain new and useful Improvements in Sewing-Machines, of which the following is a specification, reference being had to the accompanying drawings, forming part of the same.

Similar letters refer to like parts.

The object of my invention is, first, to provide a simple and durable mechanism to operate the shuttle of a sewing-machine; and, second, to provide an efficient and durable device to operate the feed mechanism of a sewing-machine; and consists in the combination and arrangement of parts, as hereinafter pointed out in the claims.

In the drawings, Figs. 1 and 5 are vertical cross-sections of the frame of the machine. Figs. 2 and 6 are vertical transverse sections. Fig. 3 is a plan of the shuttle-lever with bed of machine removed. Figs. 4, 7, and 8 are end elevations of equivalent mechanism to Figs. 1 and 5.

A is the frame of the machine; B, an eccentric on the main shaft G of the machine; C, a connecting-rod; D, Figs. 1, 2, and 8, a radius-bar; D¹, in Figs. 2, 5, 6, and 7, a slot answering the same purpose; D², in Fig. 4, a sliding block; E, the shuttle-lever; F, the feed-shaft; G, the main shaft of the machine; H, a slotted crank on the rear end of the feed-shaft; I, the fulcrum-stud of the shuttle-lever. *a*, in Figs. 1 and 8, is a fulcrum-pin of the radius-bar. D¹, in Figs. 5 and 7, is a guide-slot, in which the sliding block *b*¹ moves. *b*, in Figs. 1 and 8, are pins connecting the radius-bar with the connecting-rod C C. *b*¹, in Figs. 5 and 7, a fulcrum-pin on which C vibrates. In Fig. 4 *b*² connects the sliding block D² with the connecting-rod C C. *c c*, in Figs. 1, 2, 3, 4, and 7, is a slot or opening in the shuttle-lever E, in which the ball *d* of the connecting-rod C C works to give a reciprocating movement to

the shuttle-lever E. In Figs. 5, 6, and 8 the ball *d* is on the shuttle-lever E, and the slot *c c* is in the connecting-rod C C.

Motion being given to the machine by the rotation of the main shaft G carrying the eccentric B, a vertical motion is given to the connecting-rod C C. The connecting-rod C C being connected at *b* to the radius-bar D, or at *b*¹ or *b*² to its equivalent mechanism above described, receives a lateral movement, which it imparts to the shuttle-lever E by the ball *d* working up and down the slot *c c* of the shuttle-lever E. The extension *e* of the connecting-rod C C, as a result of the vertical and lateral movements of the lever C C, describes an elliptic circle around the center of the feed-shaft F, and by the connection of the slotted crank H to the extension *e* by the pin *f* a rotary motion is given to the feed-shaft F for operating by any suitable means the feed of the machine.

I have now fully described my invention and the manner of carrying it into effect.

What I claim is—

1. In combination with the lever C C, the radius-bar D, or its equivalent, and the shuttle-lever E, the said lever C being jointed directly to the shuttle-lever, whereby a reciprocating motion is imparted to the said shuttle-lever, substantially as shown and described.

2. In combination with the main shaft G, the feed-shaft F, the shuttle-lever E, the lever C C, and the radius-bar D, or its equivalent, the said lever C being jointed directly to the shuttle and to the feed-shaft, whereby a rotary motion of the main shaft G imparts an equal and opposite rotary motion to the feed-shaft F and a reciprocating motion to the shuttle-lever E, substantially as set forth.

THOMAS A. MACAULAY.

Witnesses:

HUGH CALLARY,
WM. KEYES.