

A. MAC BRAIR.

PROCESS OF PREPARING LABELS, SHOW-CARDS, &c.

No. 185,400.

Patented Dec. 19, 1876.

Fig. 3.

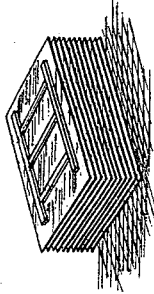

Fig. 4.

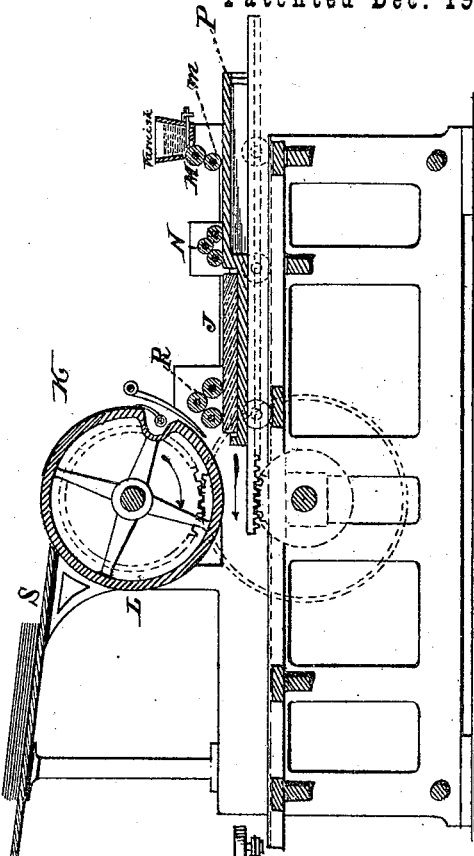

Fig. 1.

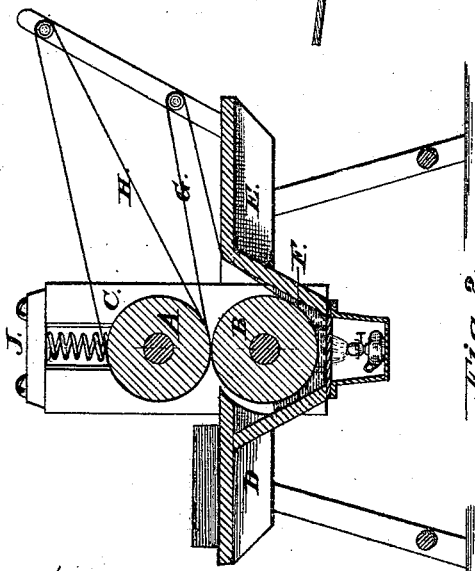
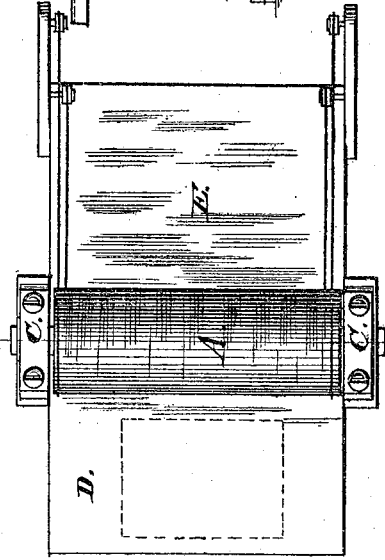

Fig. 2.



Attest:
H. L. Perrine
J. S. Coombs

Archibald Mac^r. Brair,
Inventor.

By James L. Norris
Attorney.

UNITED STATES PATENT OFFICE.

ARCHIBALD MACBRAIR, OF CINCINNATI, OHIO, ASSIGNOR OF TWO-THIRDS OF HIS RIGHT TO ARCHIBALD MACBRAIR, JR., AND WM. C. MACBRAIR, OF SAME PLACE.

IMPROVEMENT IN PROCESSES OF PREPARING LABELS, SHOW-CARDS, &c.

Specification forming part of Letters Patent No. 185,400, dated December 19, 1876; application filed August 26, 1876.

To all whom it may concern:

Be it known that I, ARCHIBALD MACBRAIR, of Cincinnati, in the county of Hamilton and State of Ohio, have invented certain new and useful Improvements in the Process of Sizing Labels and similar articles, of which the following is a specification:

This invention relates to an improved process of preparing labels, show-cards, and other like articles; the object being to give such article a highly glazed and finished surface which will resist the action of the atmosphere and moisture, and prevent in a great measure the adhesion of dirt and dust, and provide for the washing or cleansing of such articles when they become soiled, as hereinafter more fully set forth.

Heretofore, as such articles or labels have usually been made the designs have been printed upon the ordinary paper to be found in the market, which is not adapted to receive a protective coating of spirit or oil varnish, owing to the tendency of the same to strike through the paper and impair the appearance of the design; and the object of my invention is specially designed to obviate this defect. This I accomplish by giving the paper, either before or after the reception of the design or character of the label, an additional coating of size, preferably of an animal nature, as more fully hereinafter set forth, and afterward coating the printed labels with a protective varnish, such as copal, or the like, which will form a glossy and highly-finished surface for the same.

In carrying out my invention I first take the paper in sheets of suitable size, and print upon the same the designs or characters of the label in one or more colors, as may be desired. For this purpose the ordinary paper of the market may be used, in which case an extra or additional sizing is to be applied after the designs have been printed; but I prefer to have the paper prepared with a heavy sizing preparatory to the printing of the designs thereon.

In the drawing, Figure 1 represents a sectional view of the sizing apparatus which I employ to coat the paper with the animal siz-

ing; Fig. 2, a top view thereof. Fig. 3, represents a quantity of the labels placed upon racks for the purpose of drying the same, and Fig. 4 a sectional view of a portion of a cylinder-press for varnishing the labels.

The letters A and B represent two rollers mounted one above the other, the roller B being arranged to rotate in a trough, F, containing the animal sizing, and being covered with felt or other absorbent material, which will readily take up the sizing and transfer it to the sheet of paper passing between it and the upper roller.

The letter G represents a series of cords passing over the distributing-roller B, and over a small roller at the side of the apparatus, which serve to carry the coated sheets to the table E, and discharge said sheets into the hands of an attendant, who receives them. Said sheets are fed in between the rollers from a table, D, by an attendant, and are prevented from being carried up over the roller A by the cords H passing over the same, and a smaller roller, secured between the uprights I at the rear of the apparatus.

The letter K represents an ordinary cylinder printing or lithographic press, in which J represents the traveling bed, and L the cylinder, by means of which the paper is pressed into contact with the bed, as said bed and paper are passed under the same. The letter M represents a varnish-roller rotating in a trough or fountain at one end of the stationary bed of the press, and *m* a roller revolving in contact with the fountain-roller M, and with a plate, P, which is secured to the frame which carries the traveling bed of the apparatus. The letter N represents a series of distributing-rollers, which serve to spread and distribute the varnish over the plate P as it passes back and forth below the same, and R a series of rollers, located directly at the rear of the roller L, or at any convenient point over the traveling bed J, which serve to take the varnish from the plate P as it passes below them, and transfer it to the traveling bed, from which it is transferred in turn to the surface of the label.

The labels to be coated are fed onto the cyl-

inder L from a table, S, and are carried around the same, and over the traveling bed, as said cylinder rotates, and after being properly coated with varnish, is removed from the bed in any convenient manner.

The operation of my invention will be readily understood from the foregoing description.

The sheets of paper, if previously properly sized, are printed with the designs of the labels; or, if not so prepared, are printed and then run through the sizing apparatus, represented in Figs. 1 and 2. The paper thus sized and printed is then run through the cylinder-press, by means of which a uniform and smooth coating of varnish is applied to the surface of the labels, giving the same a highly and beautifully finished appearance.

What I claim, and desire to secure by Letters Patent, is—

The process, substantially as described, of preparing labels, show-cards, and other similar articles, by first printing them in the desired colors, then passing them through sizing-rollers, and, finally, glossing the same with a varnish by passing them through a cylinder-press.

In testimony whereof I have hereunto set my hand this 27th day of June, 1876.

ARCHIBALD MacBRAIR.

Witnesses:

HENRY MILLWARD,

JNO. P. MURPHY.