

F. W. YOUNG.
DRYING APPARATUS.

No. 185,418.

Patented Dec. 19, 1876.

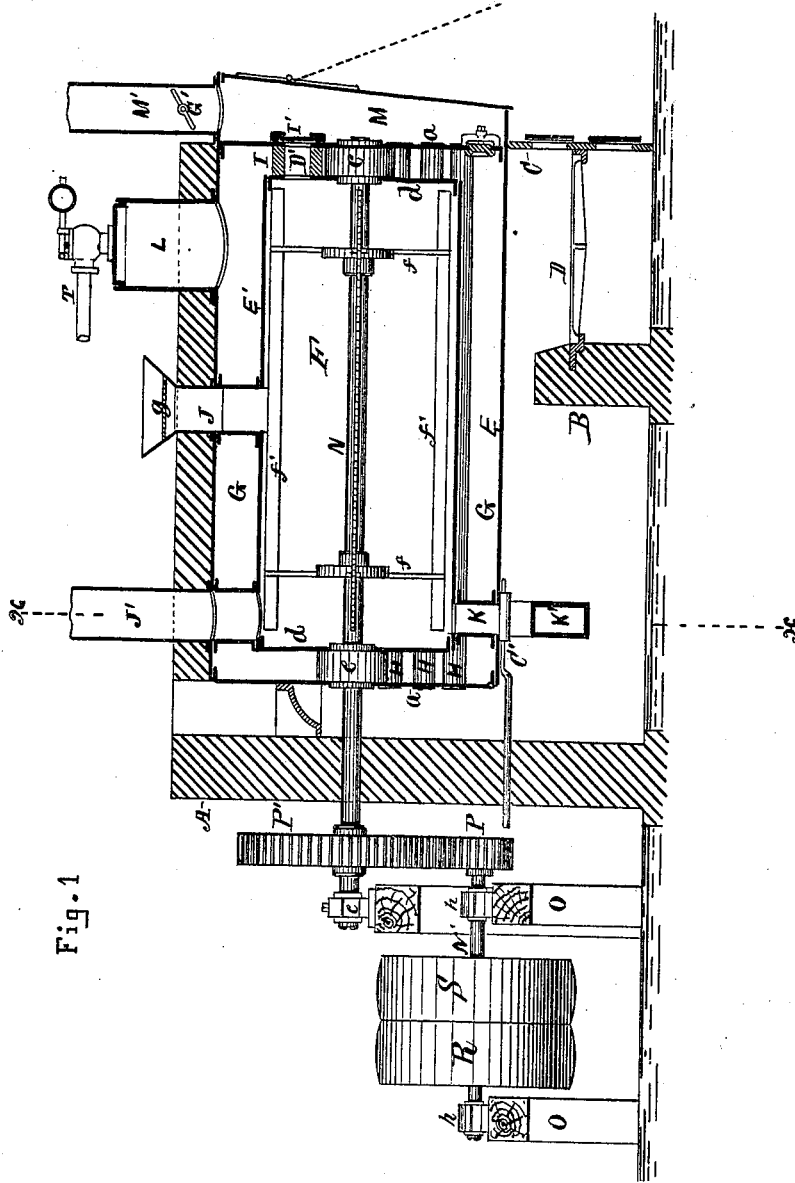

Fig. 1

WITNESSES:
Julius Wilde
A. H. Sherburne

INVENTOR
Fountain W. Young
By Sherburne & Co
Attorneys

F. W. YOUNG.
DRYING APPARATUS.

No. 185,418.

Patented Dec. 19, 1876.

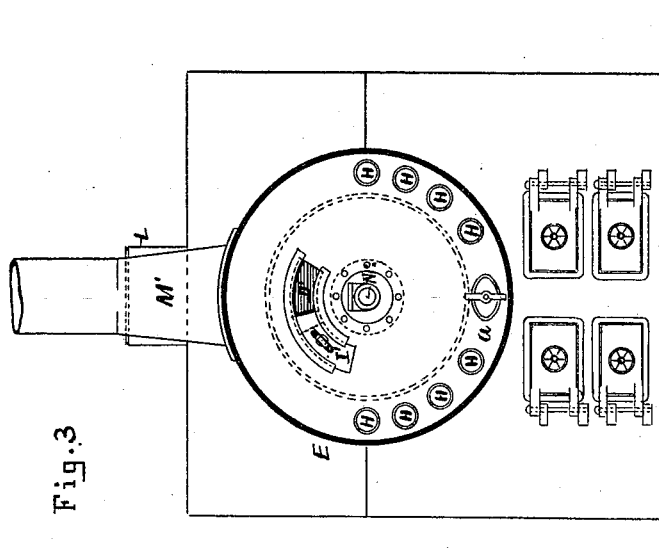

Fig. 3

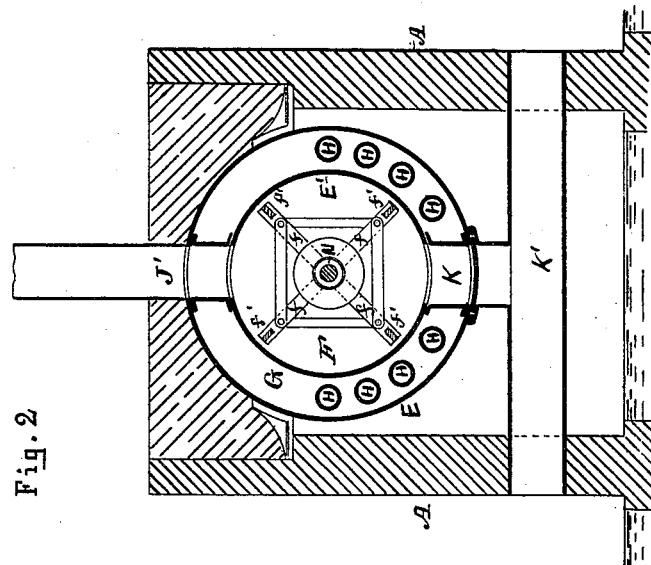

Fig. 2

WITNESSES

Julius Welch
C. H. Sherburne

INVENTOR

Fountain W. Young,
By Sherburne & Co.
Attorneys.

UNITED STATES PATENT OFFICE.

FOUNTAIN W. YOUNG, OF LAKE, ILLINOIS.

IMPROVEMENT IN DRYING APPARATUS.

Specification forming part of Letters Patent No. **185,418**, dated December 19, 1876; application filed January 3, 1876.

To all whom it may concern:

Be it known that I, FOUNTAIN W. YOUNG, of Lake, in the county of Cook and State of Illinois, have invented a new and Improved Fertilizer-Drying Apparatus; and I do hereby declare the following to be a full, clear, and exact description thereof, which will enable others skilled in the art to which it appertains to make and use the same, reference being had to the accompanying drawings, forming part of this specification, in which—

Figure 1 is a longitudinal sectional elevation of a drying apparatus embodying my said invention. Fig. 2 is a transverse section taken on the line *x x*, drawn across Fig. 1; and Fig. 3 is an end view with the boiler end removed.

Similar letters of reference indicate like parts in the several figures of the drawings.

My invention relates to that class of driers employed in drying the refuse matter from slaughter-houses for fertilizing purposes; and its object is to provide a drying-cylinder and steam-generator combined, the parts so arranged as to allow the escaping products of combustion to pass through the drying-cylinder when desired, and to utilize the heat radiating from the generated steam employed in operating the device for agitating the material within the drying-cylinder. To that end it consists in the arrangement of parts, as will be more fully understood by the following description and claims.

In the drawings, *A A* represent the walls of the furnace; *B*, the fire-bridge; *C*, the boiler-front, and *D* the grates, all of which are constructed and arranged in any suitable manner. *E* is the outer or main shell of the boiler, which is secured within the furnace in the usual manner. *E'* is the inner shell, forming the drying-cylinder *F*. The length and diameter of this shell is less than the length and diameter of shell *E*, and it is centrally located within the latter, forming a water-space, *G*, around its entire surface, between it and the outer shell, as shown in Figs. 1 and 2. *H* is a system of horizontal flues located within the water-space *G*, and extending through the ends *a a* of the outer shell. *J* is an open-ended tube communicating with the interior of the drying-cylinder through the outer shell *E*, as shown in Fig. 1, forming the admission-open-

ing through which the material to dried is introduced into the drying-cylinder. *J'* is an open-ended pipe communicating with the interior of the drying-cylinder through shell *E*, and extending upward through the roof of the building within which the apparatus is located, forming the escape-pipe, through which the smoke passes when the products of combustion are admitted into the drying-cylinder. *K* is an open-ended tube communicating with the interior of the drying-cylinder, near its end, through the outer shell *E*, and extending downward to and communicating with a horizontal pipe, *K'*, extending through the walls *A A* of the furnace, forming the exit-opening through which the dried material is discharged from the cylinder. *L* is the steam-dome, secured to the outer shell *E* in the usual manner. *M* is the smoke-box, communicating with the chimney *M'* in the usual manner. *I* is an open-ended tube or short cylinder, permanently located between the ends *a* and *d* of the outer shell and drying-cylinder, as shown in Fig. 1. One end of this tube communicates with the interior of the drying-cylinder, and the other end communicates with the smoke-box, forming an unobstructed passage, *D'*, from the smoke-box into the cylinder. *I'* is a sliding plate, secured to the outer side of the end *a* of the shell, within the smoke-box, by means of guides or ways, and so arranged as to close the passage *D'* when desired. *N* is a horizontal shaft, located centrally within the drying-cylinder *F*, and extending through the rear wall of the furnace, as shown in Fig. 1. This shaft is journaled within boxes *c c*, secured to and between the ends *a* and *d* of the outer shell and drying-cylinder, and within the box *e*, secured to frame *O*, located near the rear wall of the furnace, and is so arranged as to freely revolve. Mounted upon this shaft, within the drying-cylinder, is a series of arms, *f*, carrying horizontal bars *f'*, for agitating the material within the cylinder by the rotation of the shaft. *N'* is a horizontal shaft, journaled in boxes *h h*, secured to the frame *O*. *P* is a gear-pinion, mounted on shaft *N'*, and adapted to engage a corresponding gear, *P'*, on shaft *N*, by which means a rotary motion is imparted to said shaft by the rotation of shaft *N'*. Mounted upon shaft *N'* is a fixed

pulley, R, around which is passed a suitable belt, communicating with the band-wheel of the engine, (not shown,) by which a rotary motion is communicated to said shaft N'. S is a loose pulley mounted on shaft N', to which the belt is transferred when not necessary to rotate said shaft. T is the steam-pipe communicating with the dome, and extending to the steam-chest of the engine in the usual manner. C' is a sliding plate arranged to close the opening in tube K, the object of which is to prevent the material within the drying-cylinder from passing out before being properly dried. G' is the damper for closing the upper end of the smoke-box when desired.

The operation of my invention will be as follows: The water-space G is filled with water, and the fire within the furnace ignited, when the products of combustion pass back under the outer shell of the boiler, and return through the flues H into the smoke-box, generating steam within the water-space.

When sufficient steam to operate the machinery is generated the material to be dried is introduced into the drying-cylinder F through tube J, and the latter tightly closed by the cover g. The steam is then admitted into the steam-chest of the engine, imparting motion to the moving parts of the same, which is transmitted to shaft N' through the medium of the belt, imparting a rotary motion to said shaft, which is communicated to shaft N through the medium of pinion P and gear P', imparting a rotary motion to said shaft, causing the bars f' to move through the material within the drying-cylinder, properly agitating the same.

During the first part of the process of drying the material plate I' is removed, so as to open passage D', and damper G' in the smoke-box is tightly closed, when the products of combustion pass from the smoke-box, through passage D', into the drying-cylinder, and out through pipe J', thus bringing the products

of combustion in direct contact with the material to be dried, utilizing the heat which would otherwise be lost if allowed to pass into the chimney.

When the material is sufficiently dried, so that it would be liable to ignite by being in direct contact with the products of combustion, damper G' is opened and passage D' closed by the plate, when the escaping products of combustion pass from the smoke-box up the chimney, and the drying of the material is completed by the heat radiating from the water and steam within space G around the drying-cylinder. The drying of the material being completed, plate C' is drawn out, opening the escape-tube K, and the dry material is discharged from the drying-cylinder through tube K and pipe K'. It will be seen that with this arrangement of parts the process of drying the material is greatly facilitated by utilizing the escaping products of combustion, together with the heat radiating from the steam and heated water within the space around the drying-cylinder.

Having thus described my invention, I claim—

1. In a fertilizer-drying apparatus, the combination with the outer and inner shells E and E', forming the annular steam and water space G, and the drying-chamber F, and provided with series of flues H, as described, of the shaft N, carrying the series of bars f', for adjusting the material within the drying-chamber, substantially as specified.

2. The combination, with the drying-cylinder F, as described, of the escape-pipe J', damper G', passage D', and plate I', arranged to open and close said passage, substantially as and for the purpose specified.

FOUNTAIN W. YOUNG.

Witnesses:

JULIUS WELCKE,
J. B. THOMAS.