

F. C. MILLER.

MACHINES FOR SHAPING CIGAR-MOULD PLUNGERS.

No. 185,448.

Patented Dec. 19, 1876.

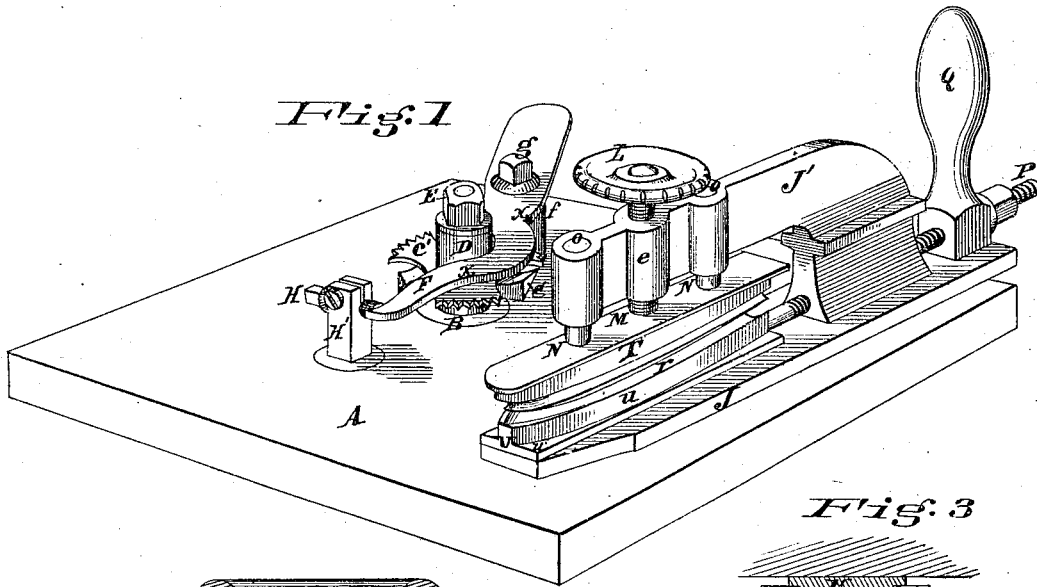

Fig. 2

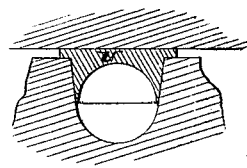
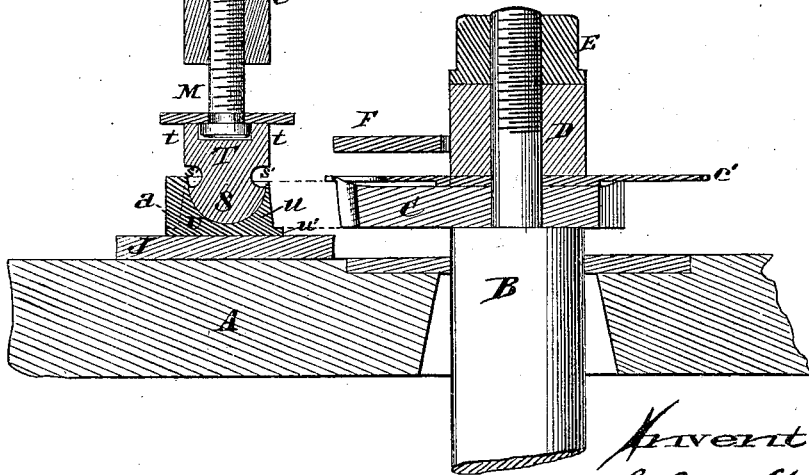

Fig. 3



Attest.

Herman Merrett
John O'Leary

Inventor:

F. C. Miller

by C. E. J. Eiler

Att'y

UNITED STATES PATENT OFFICE

FREDRICK C. MILLER, OF CINCINNATI, OHIO.

IMPROVEMENT IN MACHINES FOR SHAPING CIGAR-MOLD PLUNGERS.

Specification forming part of Letters Patent No. 185,448, dated December 19, 1876; application filed March 6, 1876.

To all whom it may concern:

Be it known that I, FREDRICK C. MILLER, of Cincinnati, in the county of Hamilton and State of Ohio, have invented certain new and useful Improvements in Machines for Shaping Cigar-Mold Plungers, of which the following is a specification:

The invention consists in mechanism for shaping or reducing cigar-mold plungers to fit the matrices in which they work, which will be understood by reference to the accompanying drawing and following description, whereof—

Figure 1 is a perspective view, and Fig. 2 a transverse section through the centers of the pattern T, plunger U, the cutter C, and shaft B. Fig. 3 represents a cross-section of plunger U in position in the mold.

A represents a table or bench; B, a shaft, carrying a revolving cutter, C. C' represents a secondary revolving cutter mounted on the same shaft. D represents a collar, and E a nut, for securing the cutters to the shaft B. F represents a gage, pivoted to the post *f*, and secured by a bolt, *g*. H represents a screw for adjusting the gage F with reference to cutter C, to compensate for the wear of the latter, which adjustment is necessary in order to enable the cutter to trim the plungers to the same thickness or width at all times. This gage is circular between the points *x x*, and concentric with the path of the cutter C, and acts as a guide for the pattern T. J represents the bed of a carriage; J', a stock; T, a pattern, having vertical surfaces *t*, conforming to the longitudinal shape or design of the wood or device wrought. U represents a plunger for a cigar-mold, the follower-surface of which is a matrix, *r*, of cigar cup shape, and the sides of which are vertical or in slightly tapering lines, and the horizontal or transverse planes are frizzed by the cutter C, to conform to the desired form or cigar shape. *v'* represents flanges formed by having the plunger deeper than the cutter C, so that only a portion of the sides is reduced by the cutter, this being the approved form of plunger. S represents a die, conversely curved to fit into the matrix of the plunger. This die is rigidly secured to the pattern T, and both are made to rise and fall for clamping and releas-

ing the piece U. N N represent slide-rods, working in guides *o o*, which are rigidly fastened to stock J. M represents a screw, working in nut *e*. The lower end of screw-rod M is swiveled to the pattern T. L represents a hand-wheel for turning screw-rod M, to raise and lower the pattern T and die S.

It is obvious that instead of a screw, cams, link-levers, or other devices may be used to advance or recede the die S.

When it is desired to trim or finish the upper face of the plunger U at the same time the sides are reduced to the desired shape, a groove or space, S', is made between the die S and pattern T, and the cutter C is made to revolve in this space and trim the top surface while the cutter C is reducing the sides. This feature of my invention is only referred to in the fourth clause of claims, and is not an element of the other claims.

P P represent a stop for holding the block *u* in place for receiving the die S. It is shown as adjustable by engaging in a nut, *p*, cut in the base of handle Q.

It is evident that this adjustable stop may be made in many known ways other than the one here shown. The cheapest form of constructing my frizzing apparatus is to have a stationary revolving cutter, reducing but one side at a time, and then reversing the carriage and reducing the opposite side.

So far as this invention relates to the pattern T and die S, arranged in a carriage so as to clamp and hold the block in position for reducing, I do not confine myself to the use of the cutter or frizzing-machine here shown, as other cutters and gages may be employed and still these features of my invention be retained.

The die S not only acts as a clamp for holding the matrix or plunger in position, but it, being of concave form, readily adjusts the cup U as the die is advanced and brings it into proper position for frizzing.

Mode of operation: The rectangular block *a'*, with the matrix *r*, is placed on the bed J under the die S, which die is advanced by the screw until it fits into the matrix *r*, and clamps the block *a'* firmly to bed J. The operator then grasps the handle Q of the carriage, and presses the front or pointed end *v'* of the pat-

tern T against the gage F, and slides the carriage forward, taking care to have the pattern press against the gage, which brings block U against the cutter C, and the right side is reduced. Reversing the carriage J J', the rear end of the pattern is brought against the guide first, the pattern T slides against the gage, as before, and the opposite side is reduced, the block released, and another placed in the carriage, and the operation repeated.

Having thus described my invention, what I claim, and desire to secure by Letters Patent, is—

1. The carriage composed, substantially, of the bed J, stock J', pattern T, and clamping-die S, substantially as set forth.

2. The movable pattern T and die S, arranged for holding and directing the block α' to the frizzing-cutter, substantially as set forth.

3. The carriage J J', pattern T, die S, in

combination with the gage F and cutter C, substantially as set forth.

4. The combination, substantially as set forth, of the pattern T, die S, and intervening groove S'.

5. The pivoted circular gage F and adjusting-screw H, in combination with revolving cutter C, substantially as set forth.

6. The combination, substantially as specified, of the carriage J J', the adjustable stop P, the die S, and pattern T.

7. The combination, substantially as specified, of the pattern T, die S, and intervening groove S', with the gage F and cutters-C C'.

In testimony whereof I have hereunto set my hand this 29th day of February, 1876.

FREDRICK C. MILLER.

Witnesses:

F. W. BROWNE,
J. B. PROUTY.