

J. C. BANNIGAN.
CULTIVATOR.

No. 185,471.

Patented Dec. 19, 1876.

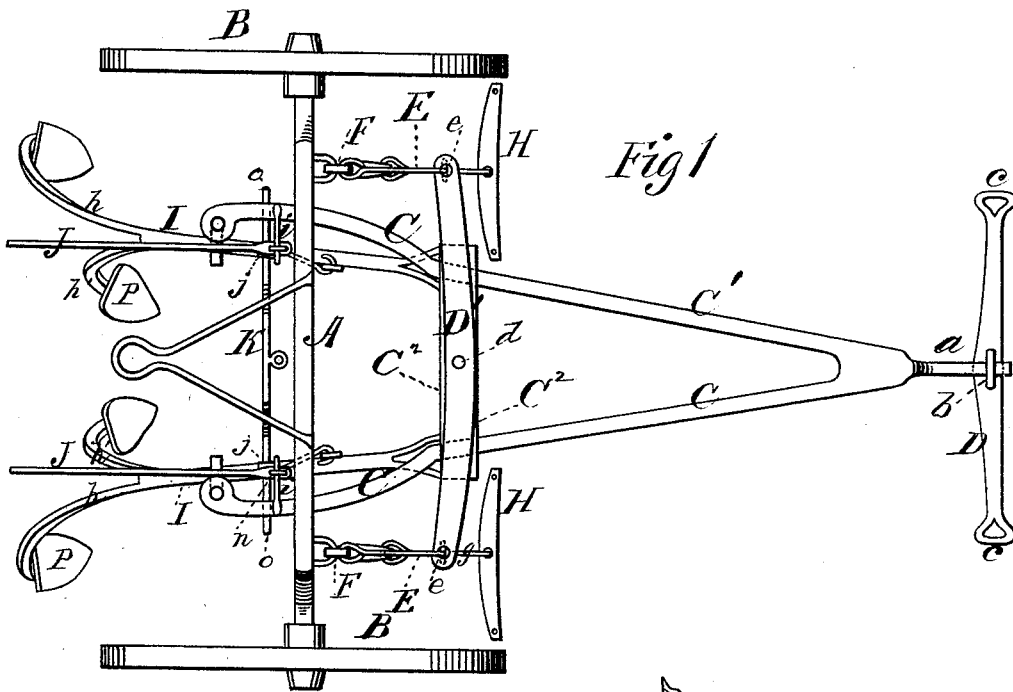

Fig 1

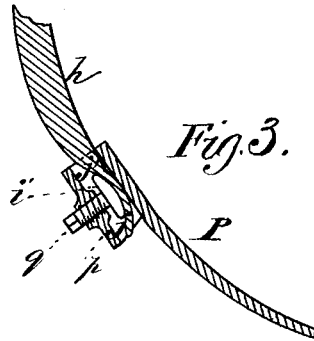

Fig 3.

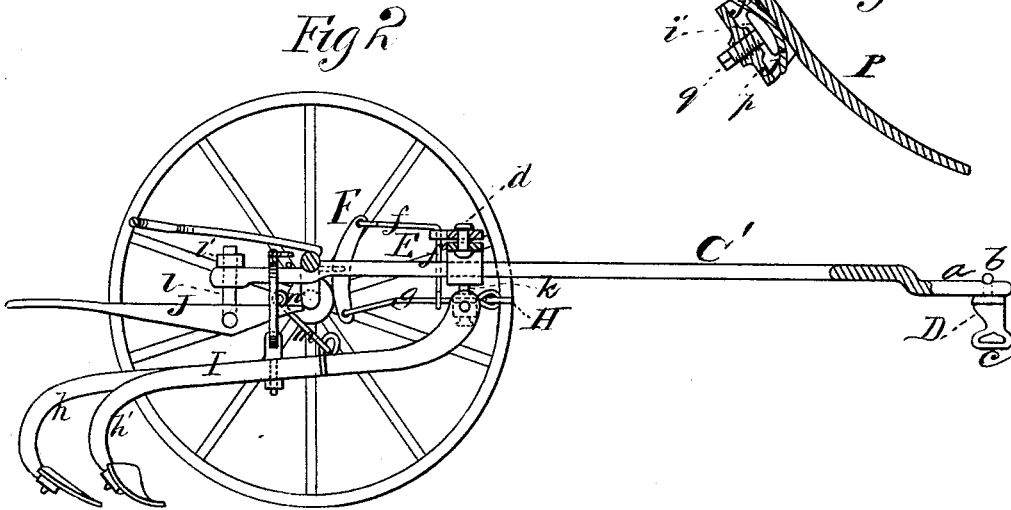

Fig 2

WITNESSES
Villette Anderson.
Mauk. J. Massi

INVENTOR
John C. Bannigan
 by *E. W. Anderson,*
 ATTORNEY

J. C. BANNIGAN.
CULTIVATOR.

No. 185,471.

Patented Dec. 19, 1876.

Fig 4

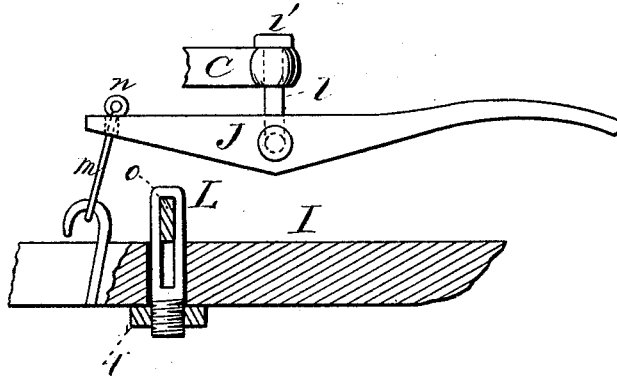
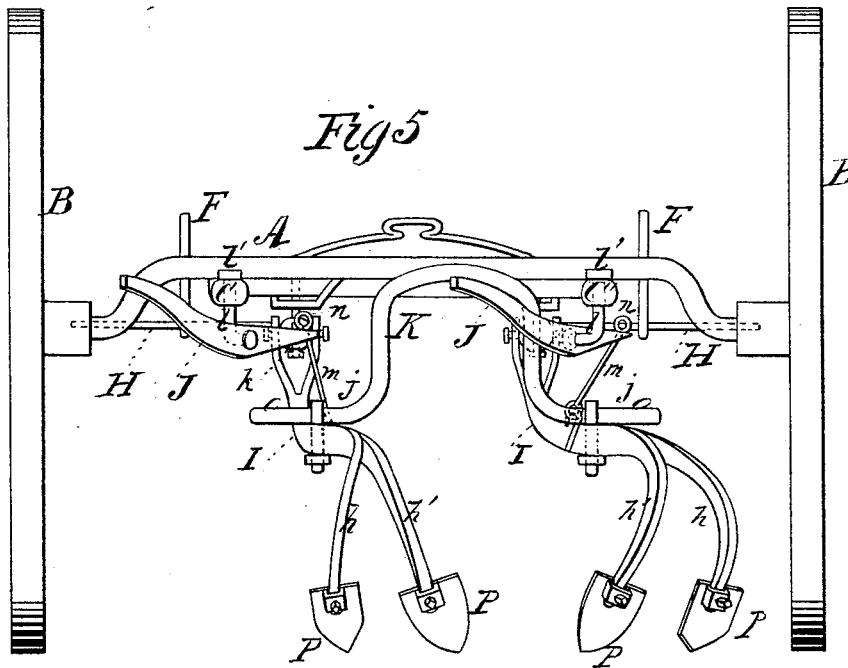

Fig 5



WITNESSES

Villette Anderson,
Francis J. Illasi

INVENTOR

John C. Bannigan,
by E. W. Anderson,

ATTORNEY

UNITED STATES PATENT OFFICE.

JOHN C. BANNIGAN, OF DUNLEITH, ILLINOIS.

IMPROVEMENT IN CULTIVATORS.

Specification forming part of Letters Patent No. 185,471, dated December 19, 1876; application filed June 17, 1876.

To all whom it may concern :

Be it known that I, JOHN C. BANNIGAN, of Dunleith, in the county of Jo Daviess and State of Illinois, have invented a new and valuable Improvement in Cultivators; and I do hereby declare that the following is a full, clear, and exact description of the construction and operation of the same, reference being had to the annexed drawings, making a part of this specification, and to the letters and figures of reference marked thereon.

Figure 1 of the drawings is a representation of a top view of my improved cultivator. Fig. 2 is a longitudinal vertical section of the same. Figs. 3 and 4 are detail views, and Fig. 5 is a rear-end view, of the same.

This invention has relation to improvements in cultivators; and it consists in the arrangement and novel construction of the various parts, as will be hereinafter more fully set forth.

In the annexed drawings, illustrating my improved cultivator, the letter A designates the axle-tree of two transporting-wheels, B, the said axle-tree being arched, so as to bring the spindles below the level of its body. C C¹ represent the side beams of the cultivator-frame, which are rigidly secured to the under side of the axle-tree by suitable bolts, and extend to the rear somewhat beyond the same, for a purpose hereinafter explained. The front ends of beams C C¹ are united to a projecting tongue, a, the free end of which passes through an eye, b, at the center of the length of a preferably metallic neck-yoke, D. This yoke is of convex form, and the convexity is upward. It is also provided with eyes c upon its downturned ends, which will have the effect, when connected with the collar-hames or breast-strap by suitable straps or chains, of raising the front end of the cultivator-frame and of allowing corn of higher growth to pass under the yoke. C² represents an arched transverse brace of the cultivator-frame, connecting the beams C C¹ in front of the axle, to which is secured, by means of a pin, d, a horizontally-vibrating double-tree, D', having at each end an eye, e. E represents a right-angular metallic rod, which is passed through eye e, one arm projecting to the rear and being horizontal, and the other

downward and being vertical. The horizontal arm f is linked to the upper end of a vertically-vibrating lever, F, fulcrumed at or near the center of its length on the axle A, with its ends projecting above and below the same, and the vertical arm f' supports in its end a metallic draft-rod, g, carrying on its front end the single-trees H, and linked at its rear end to the lower end of lever F. Arms f' being a foot or more in length, the single-trees will be a corresponding distance below the evener D'; consequently, when in use, the draft will be downward, causing the cultivators to take hold upon the ground, instead of upward, with a tendency to raise them out of the same. I represent the shovel-beams of my improved cultivator, carrying on their rear ends shovel-standards h h'. These beams are bifurcated at their front ends, and are each pivoted, so as to vibrate vertically; to the lower end of a suitable bolt, k, depending vertically from the ends of brace C². The bolts pass upward through suitably-spaced bearings in the said brace, and have free axial horizontal rotation therein; consequently beams I are not only capable of vertical, but also of horizontal, vibration. Bolts k will be prevented from detachment from their bearings by a head or pin secured on or passing through the upper ends thereof, above the said bearings. l represent angular metallic hangers, which pass upward through the rear ends of rails C C¹, and are prevented from casual detachment therefrom by means of a head or nut, l'. These hangers vibrate horizontally in their bearings in the rails or bars C C¹, and sustain upon their ends each a vertically-vibrating lever, J, the weight-arm of which is connected by means of a pivoted rod, m, to the shovel-beams. The upper ends of rods m are each provided with an eye, n, which not only serves to prevent the casual detachment thereof from the lever, but, when the shovels are raised out of the ground by depressing the said levers, and a catch, i, on the rear projecting ends of bars C C¹ engaged therewith, also to hold the said shovels in this position, when the machine may be driven from the field or from place to place as an ordinary vehicle, the points of the shovels being above the surface of the soil. In order to adjust the beams I to or from each

other in accordance with the spacing of the corn-rows, as well as to brace them transversely, I have devised the following: Beams I will be provided each with a strong rectangular loop, *j*, the openings in which will be in the same line transverse to the central line of draft. In these openings will be engaged the arms *o* of an arched brace or adjuster-rod, K, the said arms being rectangular in section to correspond to the form of the loops. Arms *o* extend laterally as far as may be desirable, and as the loops are designed to fit loosely thereon the beams I may be drawn toward or from each other, as the necessities of the case may require. In order to hold them in the desired position or at the desired distance from each other when obtained, I shall employ a clamp-screw, which, passing through the upper screw-threaded wall of loops *j*, will bear upon the beams when set up and hold them in position; or I may employ an eyebolt, L, inclosing each of the said arms *o*, which latter are jammed against the beams by the setting up of a nut or burr, *t*, upon the lower end of the said bolt, projecting through the beams. The shovels P are secured to their respective standards in the following manner, to wit: The shovel is provided with an open bridge-like loop, *p*, of a size adapted to receive the lower recurved end of the standards, and a screw-bolt, *q*, passes through a screw-threaded hole in the bridge, and clamps the shovel and its standards together. In order to render the attachment of the shovel and standard more stable and reliable, the inner end of bolt *p* will have an enlarged rounding head, *i'*, which will be received into a correspondingly-shaped concavity, *j'*, in the lower rear end of

the standards; consequently, when the bolt is forcibly set up, it will enter the concavity in the end of the standard, and rigidly hold the shovel in position.

What I claim as new, and desire to secure by Letters Patent, is—

1. In a cultivator, the combination, with the vertically and horizontally-vibrating shovel-beams I, of the tripping-levers J, the angular journal-rods *l*, depending from and rotating axially in the rear ends of the bars O O', and affording bearings for the said levers, and the pivoted rods *m*, substantially as specified.

2. The levers F, pivoted to vibrate vertically on the axle-tree, in combination with the angular rods E, the evener D', draft-rods *g*, secured to the lower end of the said lever, and sustained by the vertical arm of the angular rods E, substantially as specified.

3. In combination, the shovel-point P, having metallic bridge *p* and set-screw *q*, with enlarged rounding head *i'*, and the standard *h*, having a concave recess in its lower end, adapted to receive the said head, substantially as specified.

4. In combination with the beams I and levers J, the rod *m*, connecting the same, and provided with an eye, *n*, upon its upper end, adapted to engage with a projecting spur, *i*, upon the ends of bars O O', substantially as specified.

In testimony that I claim the above I have hereunto subscribed my name in the presence of two witnesses.

JOHN C. BANNIGAN.

Witnesses:

FRANCIS COYLE,
JOSEPH LEITHNER.