

J. BONFIELD.  
DRYING APPARATUS.

No. 185,480.

Patented Dec. 19, 1876.

Fig. 1 [a]

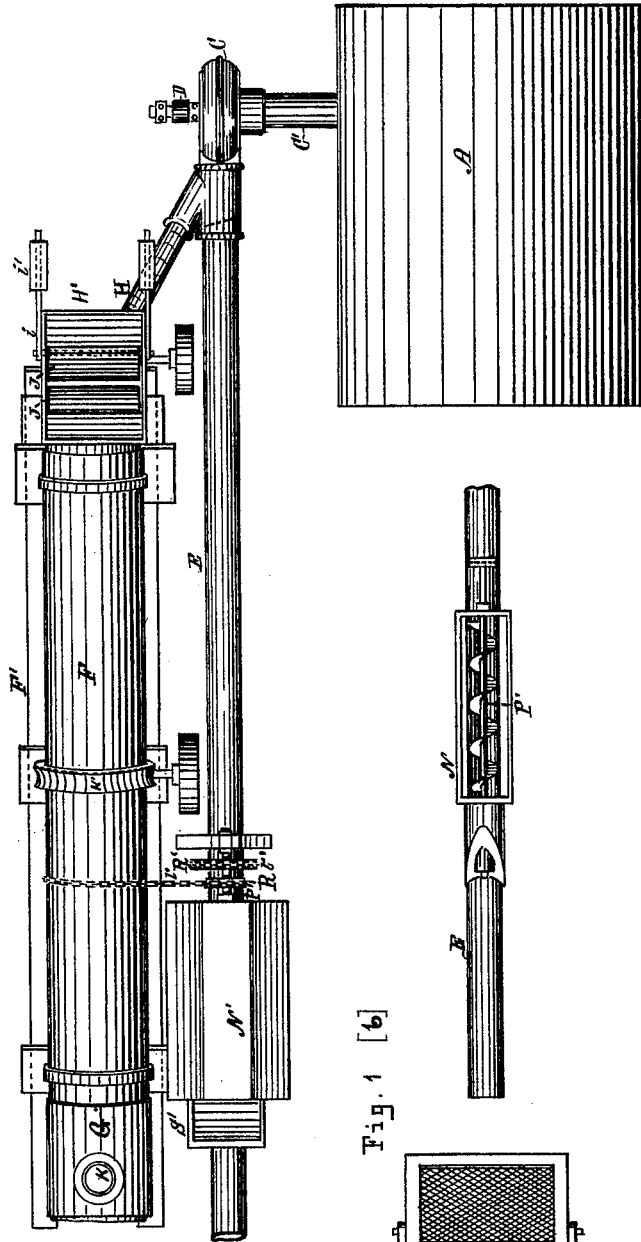
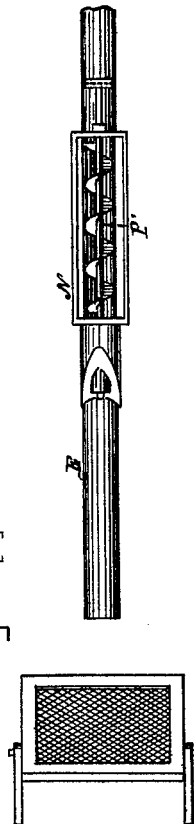

Fig. 1 [b]



WITNESSES:

*Julius Wilcke*  
*M. H. Sherburne*

INVENTOR:

*John Bonfield*  
*By Girdley & Sherburne*  
*Atty*

J. BONFIELD.  
DRYING APPARATUS.

No. 185,480.

Patented Dec. 19, 1876.

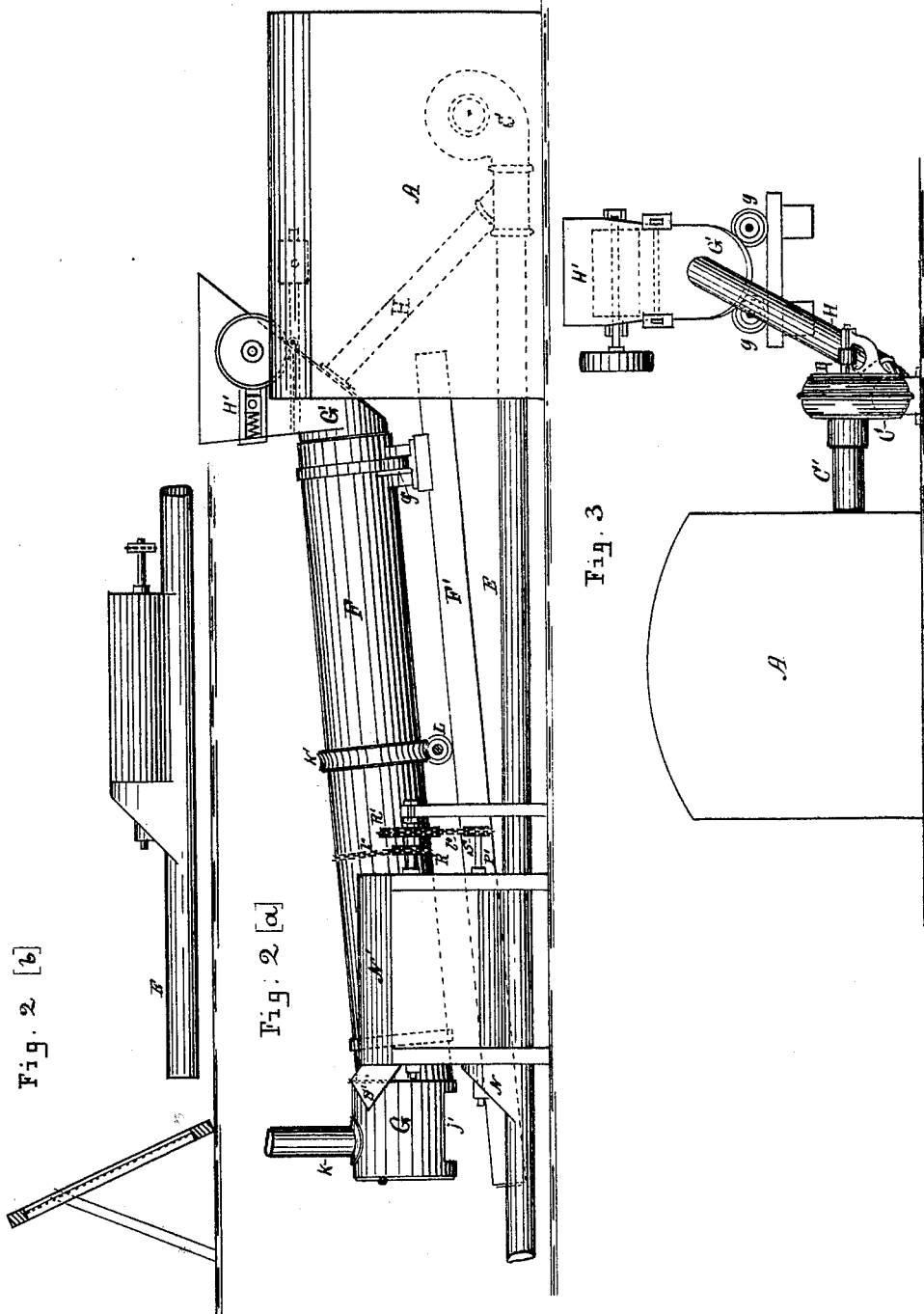

WITNESSES:  
*Julius Witke*  
*Chas. Sherburne*

INVENTOR:  
*John Bonfield*  
*By Lindley D. Sherburne*  
*Atty*

J. BONFIELD.  
DRYING APPARATUS.

No. 185,480.

Patented Dec. 19, 1876.

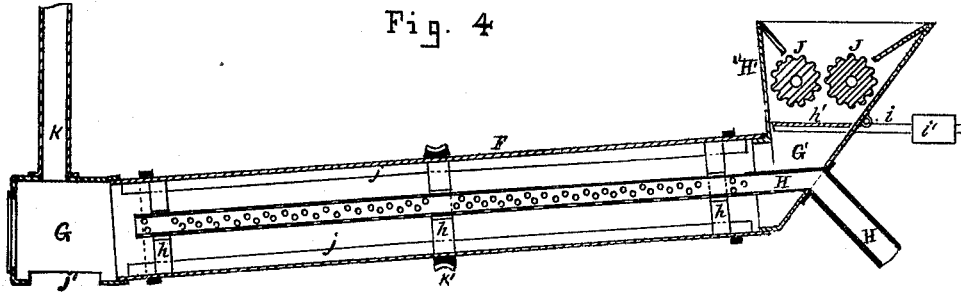

Fig. 4

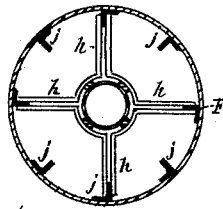

Fig. 5

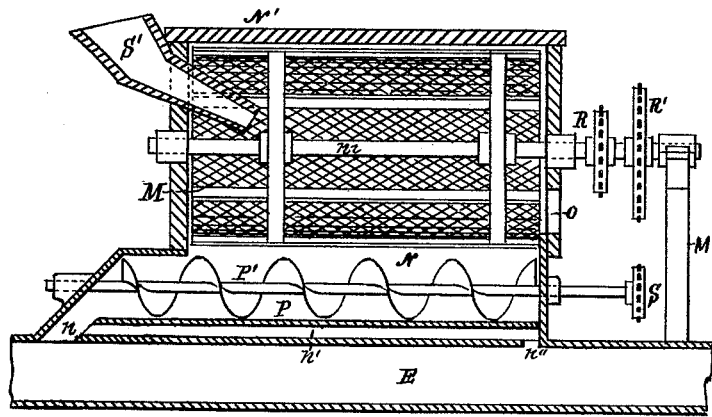

Fig. 6

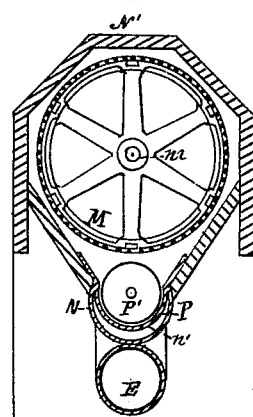

Fig. 7

WITNESSES:  
*Julius Wilcke*  
*A. H. Sherburne*

INVENTOR:  
*John Bonfield*  
 By *Guidley & Sherburne*  
*Atty*

J. BONFIELD.  
DRYING APPARATUS.

No. 185,480.

Patented Dec. 19, 1876.

Fig. 8

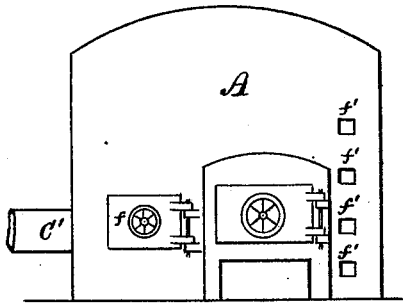

Fig. 9

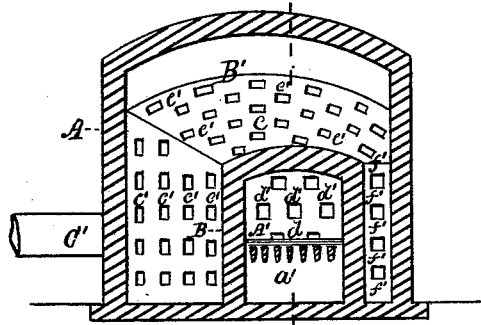

Fig. 10

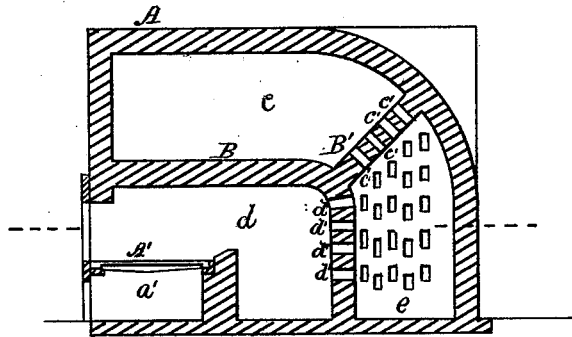
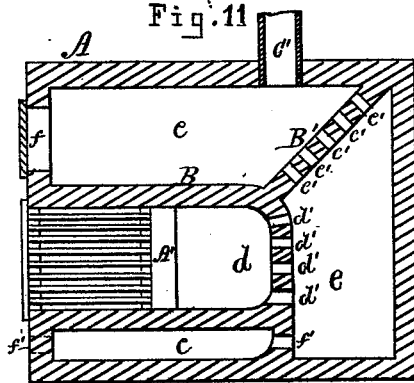

Fig. 11



WITNESSES:

*Julius Wilcke*  
*Wm. C. Sherburne*

INVENTOR:

*John Bonfield.*  
*By Bradley & Sherburne.*  
*Atty.*

# UNITED STATES PATENT OFFICE.

JOHN BONFIELD, OF CHICAGO, ILLINOIS.

## IMPROVEMENT IN DRYING APPARATUS.

Specification forming part of Letters Patent No. 155,450, dated December 19, 1876; application filed October 23, 1876.

### *To all whom it may concern:*

Be it known that I, JOHN BONFIELD, of Chicago, in the county of Cook and State of Illinois, have invented a new, useful, and Improved Drying Apparatus for Treating Refuse from Slaughter-Houses for Fertilizing Purposes; and I do hereby declare the following to be a full, clear, and exact description thereof, which will enable others skilled in the art to which my invention appertains to make and use the same, reference being had to the accompanying drawings, forming part of this specification, in which—

Figure 1<sup>a</sup> represents a general plan or top view of a drying apparatus embodying my invention, and Fig. 1<sup>b</sup> represents a detail section of the conducting-pipe, showing a top view of the receiving-hopper and worm. Fig. 2<sup>a</sup> represents a side elevation of my said drying apparatus; and Fig. 2<sup>b</sup> represents a detail section of the conducting-pipe, showing a side elevation of the receiving-hopper. Fig. 3 represents an end view of my said drying apparatus. Fig. 4 represents a longitudinal central section of the drying-cylinder; and Fig. 5 represents an enlarged transverse section of the same. Fig. 6 represents an enlarged longitudinal central section of the separating-screen and receiving-hopper, showing their connection with the conducting-pipe; and Fig. 7 represents a transverse section of the same. Fig. 8 represents an end view of the hot-air furnace; and Fig. 9 represents a vertical transverse section. Fig. 10 represents a vertical longitudinal section, and Fig. 11 represents a sectional plan of the same.

Like letters of reference indicate like parts.

My invention relates to that class of drying apparatus in which the material to be dried is passed through a drying-cylinder and conducting-pipe in contact with a current of heated air; and the objects of my invention are to facilitate the heating of the air, and to so introduce the material into the drying-cylinder and conducting-pipe as to prevent the escape of the volume of heated air. To that end my invention consists in the arrangement of the various parts of said drying apparatus, as is hereinafter more fully described and claimed.

In the drawing, A represents the furnace proper, which is constructed of any suitable

material, and with inner walls B and B', so as to form a series of chambers, *c*, *d*, and *e*, the chamber *d* constituting the fire-box. A' represents the grate, which is arranged within the fire-box in the usual manner, and so as to form an ash-pit, *a'*, beneath it, as shown in Fig. 10. The arrangement of the chamber *c* is such as to extend over the top and sides of the fire-box, and communicate with chamber *e* through a series of flues, *c'*, formed in the wall B', as shown in Figs. 9 and 11. *d'* represents a series of smoke-flues, which are formed through the wall B at the back of the fire-box, and communicate with chamber *e*. *f* and *f'* are cold-air flues, which are formed through the front wall of the furnace and communicate with the chamber *c*, and through said flues a volume of cold air is admitted into said chamber when required. The said flues *f* and *f'* are provided with suitable doors, so arranged as to admit of being opened and closed at will, and so as to regulate the amount of cold air admitted into the chamber. C is an ordinary exhaust-fan, which communicates with chamber *e* of the furnace through pipe C', and is rotated by means of a belt, (not shown,) which passes around pulley D and connects with any suitable motor. E is a conducting-pipe, connected to the fan-case, and extends to a point where the dried material is to be deposited. F is the drying-cylinder, which is journaled at its ends upon and around the short stationary cylinders G and G', permanently attached to a suitable frame-work, F', and is so arranged as to freely revolve, and is also supported at a point near its ends upon anti-friction wheels *g* journaled in suitable boxes attached to the frame. The short cylinders G and G' are made open at their inner ends, so as to communicate with the interior of the drying-cylinder, and are closed at their outer ends so as to prevent the escape of any of the material from them. H is a hot-air pipe, which is connected at one end to the conducting-pipe E near the fan-case, and passes centrally through the end of the cylinder G' into and centrally through the drying-cylinder, as shown in Fig. 4, and is supported therein by suitable bearings *h*, so adjusted as to allow the cylinder to revolve independently of the pipe. That part of the pipe H extending

through the drying-cylinder is perforated, as shown in Fig. 4, so as to allow the volume of heated air within the pipe to escape therefrom laterally into the material in the cylinder, and distribute the air evenly the entire length of the cylinder.

Mounted upon the cylinder G' is a hopper, H', arranged to communicate with the interior of said cylinder. Hinged to the interior of said hopper H', and extending over the entire area of the same near the upper surface of the cylinder, is a bottom or valve, h', to which is attached a lever, i, passing through the wall of the hopper, and upon which is mounted an adjustable weight, i', arranged to admit of being moved toward or from the hopper at will. The arrangement of this bottom or valve is such as to tip downward under the weight of the material in the hopper, so as to allow the material to pass into the cylinder when the valve is moved back to its normal position by the gravity of the weight i' after the material has passed off, thereby preventing the escape of the heated air from the cylinder. J J are feed-rollers, which are journaled to the end walls of the hopper H' immediately above the valve h', and are so arranged as to admit of being moved toward or from each other, and are made to rotate by any suitable means. The rollers J J are fluted longitudinally, as shown in Fig. 4, and are so adjusted relative to each other as to cause the material in the hopper to pass between them, for the purpose of crushing any lumps or hard substance which may be in the material, and feed the material evenly upon the valve prior to passing into the drying-cylinder.

The drying-cylinder is arranged on an incline, as shown in Fig. 4, and is provided internally with a series of radial flanges, j, projecting inward from the shell, as shown in Fig. 5, so as to agitate the material as it is being rotated within the cylinder, and to cause the material to move through the drying-cylinder into cylinder G, and from which it is discharged upon the floor through the opening j' in said cylinder G. K is an escape-pipe, communicating with the interior of the drying-cylinder through cylinder G, and through which the foul gases generated in the drying-cylinder are allowed to escape. K' is a spiral gear mounted upon the drying-cylinder, and engages with a corresponding gear, L, on a horizontal shaft, which connects with any suitable motor, and by which means a rotary movement is imparted to the said cylinder. M is a cylindrical revolving screen, mounted upon the horizontal shaft m, journaled to a suitable frame-work, M', located above the conducting-pipe E. N is the receiving-hopper located immediately under the screen M, and between it and the conducting-pipe, and communicates with the interior of said pipe through the discharge-opening n, as shown in Fig. 6. N' is a cylindrical case inclosing the screen M, and communicating with the entire

length of the receiving-hopper. P is a concave bottom or jacket, arranged within the lower part of the receiving-hopper, so as to form an air-space, n', between its lower surface and the upper surface of the bottom of the hopper, as shown in Figs. 6 and 7, said air-space communicating at one end with the discharge-opening n, and at the opposite end with the interior of the conducting-pipe through the opening n'' formed in said pipe. P' is a worm-shaft journaled within the ends of the receiving-hopper, and is so adjusted as to revolve within the concave of the jacket. R is a chain-wheel mounted upon the shaft of screen M, and around which wheel passes a chain-belt, r, extending around the drying-cylinder, so as to impart a rotary movement to said screen by the rotation of the cylinder. R' is a like chain-wheel mounted on the outer end of the shaft of said screen, and around which wheel is passed a chain-belt, r', which passes around a chain-wheel, S, on the shaft of the worm, so as to impart a rotary motion to the said worm by the rotation of the screen-shaft. S' is a hopper arranged within the end of the screen-case, and communicates with the interior of the screen, and through which hopper the material is introduced into the screen. O is a discharge-opening formed in the end of the screen-case opposite the hopper, and through which the material too coarse to pass through the meshes of the screen is discharged from the case.

Ordinarily, in treating animal matter for fertilizing purposes, the raw material, such as the refuse from slaughter-houses, is first dried in a heated cylinder until it becomes a fine pulpy mass, when it is removed from the cylinder and allowed to dry in the open air. This process leaves the mass solid when dry, and which must be pulverized before it can be used for fertilizing purposes, whereas, by the use of my said apparatus, the mass is left in a powdered condition when dried.

In using my said apparatus, a sufficient quantity of fuel to produce the required heat is placed within the fire-box and ignited. Motion is then imparted to the fan, and thereby drawing a volume of air through the fire-box, when the air becomes heated and passes into chamber e through the flues d', and from thence into chamber c through the flues c', and then passes into the fan-case through pipe C', and is discharged from the fan-case into the conducting-pipe E, when a portion of said air passes from said pipe E into the drying-cylinder F through pipe H. In the event that the volume of air when passing through the fire-box should be too highly heated, the flues f and f' are partly opened, so as to admit of a current of cold air into chamber e, which intermingles with, and regulates, the temperature of the heated air as may be desired.

The pulpy mass as it is taken from the drying-cylinder, as aforesaid, is introduced into the hopper H', and from thence passes between the feed-rollers J J to and upon the valve h';

thence through cylinder G' into and through the drying-cylinder F, and in contact with jets of heated air escaping from the pipe H, and by the rotation of said drying-cylinder the mass is kept in motion until nearly dry, when it is discharged from the drying-cylinder upon the floor through the opening j' in cylinder G. The screen M and worm P' being in motion, the material discharged from the drying-cylinder is introduced into the screen through hopper S', when the particles which are too coarse to fall through the meshes of the screen pass off through the opening O, and the material which passes through the screen falls into the receiving-hopper N, and by the rotation of the worm is forced from said hopper through the discharge-opening n, into the conducting-pipe E, and in contact with the volume of heated air in said pipe, and is thereby forced through said pipe, thoroughly drying the material, and discharging it from the pipe in a powdered state ready for use. The coarser particles which have passed through opening O are again passed through the feed-rollers and properly crushed, when they pass into and through the drying-cylinder, as previously described.

Having thus described my invention, what I claim as new, and desire to secure by Letters Patent, is—

1. In a drying apparatus for treating fertilizing material, the combination, with the drying-cylinder F, fan C, and pipes E, H, and C', of the furnace A, provided with the fire-

box d, chambers c and e, and passages e', and d', and ff', substantially as and for the purpose specified.

2. The combination, with the conducting-pipe E and receiving-hopper N, communicating with the conducting-pipe through the opening n, of the worm P', substantially as and for the purpose specified.

3. The combination, with the conducting-pipe E, hopper N, and worm P', of the revolving-screen M, substantially as and for the purpose specified.

4. The combination, with the air-heating furnace A, fan C, pipe C', conducting-pipe E, and rotary drying-cylinder F, of the stationary hot-air pipe H, extending centrally through the drying-cylinder, and perforated to admit of the escape laterally of the jets of heated air, substantially as and for the purpose specified.

5. In a drying apparatus for treating fertilizing material, the combination, with the rotary drying-cylinder F, stationary chamber G', and hopper H', of the feed-rollers J J, substantially as and for the purpose specified.

6. The combination, with the conducting-pipe E and receiving-hopper N, of the concaved jacket P, forming the air-space n', substantially as and for the purpose specified.

JOHN BONFIELD.

Witnesses:

N. C. GRIDLEY,  
N. H. SHELBURNE.